



Hamworthy Purewell VariHeat

High Efficiency, Fully Modulating Boilers
Condensing & Non Condensing
Cast Iron, Pre-mix, Modular Gas Fired
Single Boiler Outputs 65kW to 180kW



Heating *at work.*

Purewell VariHeat

High Efficiency, Condensing
& Non Condensing
Fully Modulating, Pre-mix
Modular Gas Fired Boilers

The Purewell VariHeat is the simple direct replacement for cast iron atmospheric boilers, with low emissions and durability built in as standard. All models comfortably exceed the minimum seasonal efficiency requirements for the Building Regulations (Amendment 2006), making the Purewell VariHeat the perfect choice for existing buildings and new buildings.

Occupying the same small space as its predecessors, but with up to 50% more output, the Purewell VariHeat is a high efficiency boiler range that can suit condensing or non condensing systems, and is available in 5 condensing models with outputs from 70kW to 180kW, and 4 non condensing models, 65kW to 125kW.

Purewell VariHeat boilers feature a control system that uses an LPB bus communication system, which simplifies the controls requirements. Clip-in modules integrate the boiler and building control capabilities with an extensive range of options which include boiler sequencing for up to 12 boilers in a multiple boiler installation.

Completing the Purewell VariHeat package is a range of optional pipework kits to simplify design and procurement. The pipework kits are available for 2, 3 or 4 multiple boilers and are factory tested and part assembled for ease of installation.

Options

- **Boiler sequencing cascade controller**
- **Room sensors**
- **LPB bus communications modules**
- **Outside air sensor**
- **Zone controller**
- **DHW cylinder sensor kit**
- **Pipework header kit**

- **Energy saving high efficiency performance**
- **Models for 11°C Δt and 20°C Δt systems**
- **Robust cast iron heat exchanger**
- **Simple design, reliable performance**
- **Tolerant of older heating systems**
- **Fully assembled for faster installation**
- **Close control and accurate load matching**

BENEFITS

Purewell VariHeat is the fully compliant direct replacement for cast iron atmospheric boilers, with 50% more output, matched system temperatures and comprehensive controls capability.



Purewell VariHeat high efficiency condensing boilers with a Dorchester DR-FC condensing water heater.

Specification

Purewell VariHeat Natural Gas

Hamworthy have designed the Purewell VariHeat to retain all the benefits of traditional boilers, but with vastly improved performance to more than meet the performance requirements for modern day boilers.

Purewell VariHeat boilers can be used as single boilers, or as modules in a multiple boiler installation. Each boiler is equipped with a pre-mix down firing burner, cast iron primary heat exchanger and a control panel, all enclosed in a stylish factory fitted casing. As a modular boiler, the Purewell VariHeat can be installed with up to six boilers on a single flue header, condensing outputs reaching 1080kW, and centres are the same as the Purewell and UR predecessors, simplifying replacement. The boilers are suitable for use in open vented or pressurised systems and have a maximum working pressure of 7 bar.

Construction

A down firing fully modulating gas burner is fitted on top of the primary cast iron heat exchanger and on the condensing models, a secondary heat exchanger is positioned in the base of the boiler to maximise heat recovery from the flue gases.

The boilers are delivered fully assembled, but for plant rooms with difficult access, it is a simple task to separate the individual sections for easier handling.

The boilers are finished externally using steel side panels and stylish moulded plastic front and top covers, which give excellent access for servicing and maintenance.

Performance

Purewell VariHeat condensing boilers achieve a full load efficiency up to 93.7% gross (104% nett), whilst at part load the efficiency rises to 97.5% gross (108% nett). This equates to seasonal efficiencies up to 96% gross.

The high efficiency non condensing models achieve seasonal efficiencies up to 91% gross, exceeding the Building Regulations minimum seasonal efficiency requirements of 84% gross, for new buildings and existing buildings.

All boilers achieve European Class 5 performance for NO_x emissions.

Flue System

The Purewell VariHeat is a high efficiency boiler, and like all other high efficiency appliances, requires a water tight flue system that will retain condensate whilst working under positive pressure.

The boiler is fitted with a primary flue connection directly into the base assembly. The connector is fitted as standard with a tri-lip full ring silicone seal which is impervious to water and vapour, ensuring a water tight flue joint. It is compatible with the Hamworthy Masterflue range of stainless steel flue components which are available in single or twin wall formats, and can be interchanged to provide a safe and effective flue system. *Refer to page 26 for more details.*

A fixed draught diverter is not required in the flue system, however, a draught stabiliser is recommended for some installations.

Flue Terminal Location

Purewell VariHeat condensing boilers will produce condensate due to their high thermal efficiency. The effect of this condensate production is to produce plumbing from the flue terminal, and careful consideration must be given to the location of the flue terminal. Should plumbing be a concern, then the flue system should be designed to discharge at high level so as not to cause a visual intrusion to the building occupants.

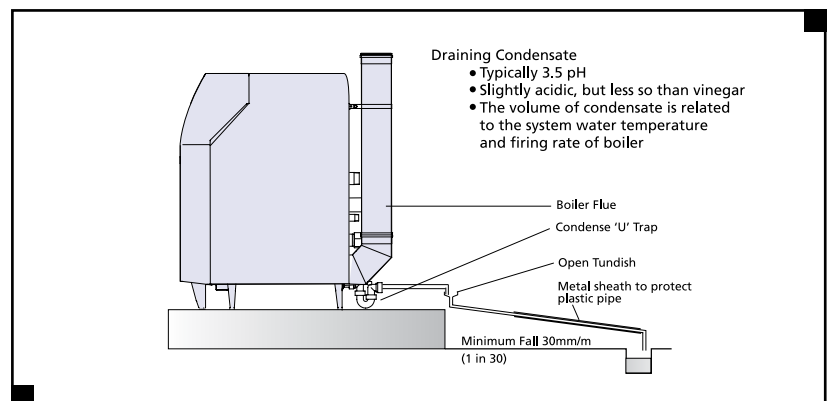

Condensate Discharge

The condensate drains safely into the base assembly and a 32mm diameter drain connection is provided, to run in standard plastic waste piping. This condensate drain must be connected to a suitable drainage system, typically as shown above. The material should be a suitable PVC plastic system with sealed joints to prevent the escape of condensate.

Drain traps and an open tundish should be incorporated into the design, and the pipework given appropriate protection from physical damage.

The pipework should be installed with at least a 3 degrees fall (approximately 50mm per metre).

Specification

Purewell VariHeat
Natural Gas

Primary Heat Exchanger

Each boiler has a cast iron primary heat exchanger arranged with horizontal sections, connected at one end only to allow expansion and contraction, retaining a proven horizontal series water flow for even hydraulic distribution.

The primary heat exchanger is fitted on top of the base assembly, which encloses the secondary heat exchanger on the condensing models.

The high efficiency non condensing models are designed for a traditional 11°C Δt temperature rise and have a minimum return temperature of 50°C .

Secondary Heat Exchanger

Condensing performance is achieved by returning the system water through a copper/aluminium composite construction secondary heat exchanger and extracting the latent heat from the flue gases in the base of the boiler. In keeping with most modern high efficiency boilers, the condensing heat exchanger is designed for 20°C Δt temperature rise, with minimum flow temperature of 40°C , maximizing the opportunity for condensing performance.

Burner

The Purewell VariHeat features a fully modulating pre-mix burner control system. An electronic thermostat monitors the boiler operating conditions and automatically adjusts the output to suit.

The gas/air ratio control system ensures that clean and efficient combustion is maintained throughout the maximum modulation range, down to a minimum of 20% capacity.

The plaque burner is positioned centrally above the primary heat exchanger and is constructed using a FeCrAl Aconit woven mesh. This design of burner allows for good flame stability at low turndown rates. The woven fibre construction of the burner also results in lower flame temperatures being achieved and lowering NOx emissions.

Reduced Boiler Weight

Purewell VariHeat boilers have been reduced in weight significantly, in comparison to traditional atmospheric cast iron boilers, with weights as low as 1.3 Kg/kW output. The new casting designs are extremely efficient therefore fewer sections are required to produce the given boiler outputs.

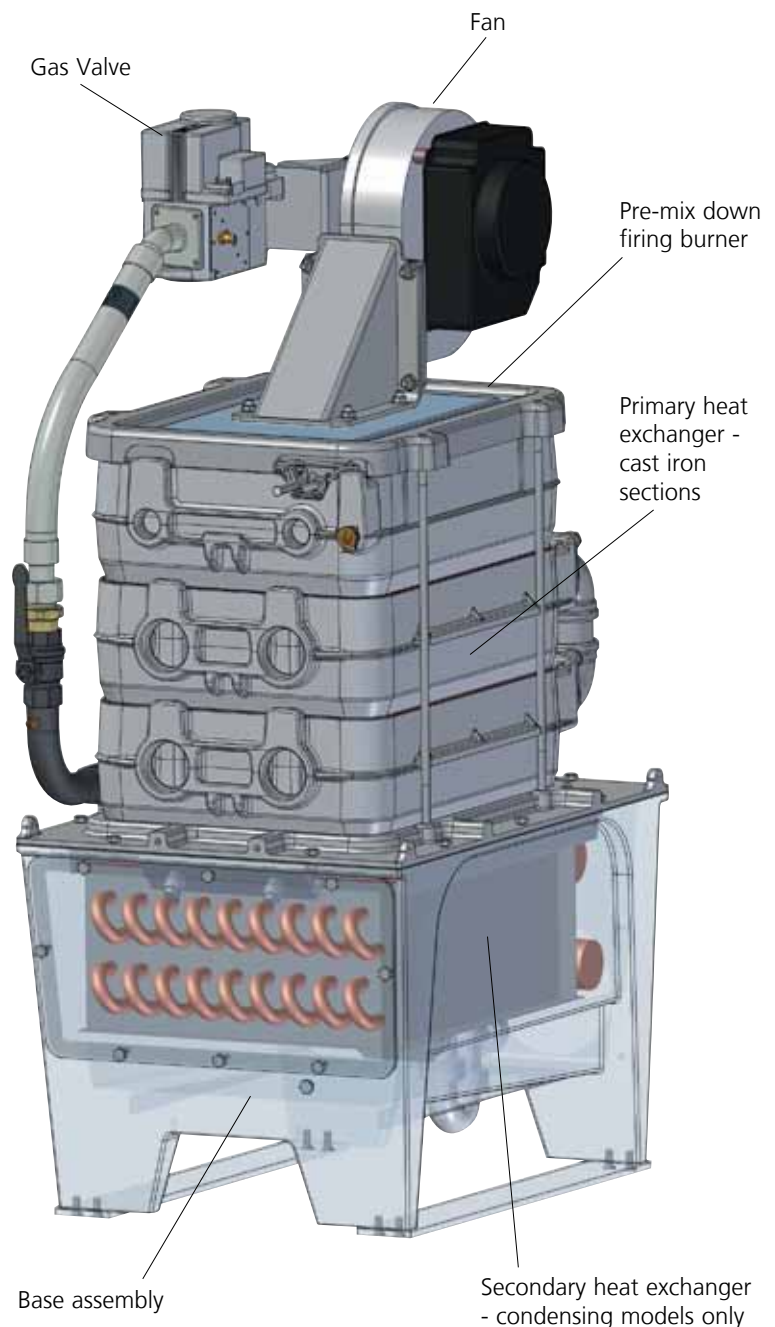

Purewell VariHeat - heat exchanger arrangement, PV 180c

Boiler Thermostats

Purewell VariHeat boilers are fitted with a manual reset limit thermostat, which has a range of 90-110°C on all models. This will be factory set to 100°C.

Condensing boilers have an electronic control temperature range 30-90°C, whereas the high efficiency non condensing models have a range from 50-90°C.

The electronic temperature control thermostat regulates the boiler flow temperature up to a maximum setting of 90°C.

To accommodate multiple boiler installations, the limit thermostat is adjustable up to a maximum of 110°C, however where the boiler control thermostats are to be set higher than 83°C, adequate system pressure must be available either by gravity head or system pressurisation.

Refer to page 20 for applications and system data.

The boiler also incorporates a return temperature sensor, which in conjunction with the flow temperature sensor, governs the modulation set point of the boiler.

Pipework Kits

Designed to save time and simplify procurement, optional pipework kits are available from Hamworthy. The kits enable multiple boilers to be connected in configurations of 2, 3 and 4 boilers. The pipework kits are factory tested and supplied part assembled for ease of installation.

Pipework kits include:

- Isolating ball valves for water flow, return and gas inlet connection on each boiler, flow isolation uses a three port vent valve to prevent fully sealing the boiler when isolated
- Flow and return headers
- Pre assembled flow and return pipe sub assemblies between boilers and headers. Connections for gauges, sensors, safety relief valve, feed and vent pipes (gauges, instrumentation and safety relief valves not included)
- Blanking flanges for header ends
- Support legs



Purewell VariHeat-pipework assembly

Non Condensing Outputs @ 82/71°C flow/return temperatures

Boiler Model	Min output kW	Heat output according to number of modules installed - kW							
		1	2	3	4	5	6	7	8
PV 65he	21.5	65	130	195	260	325	390	455	520
PV 85he	30.1	85	170	255	340	425	510	595	680
PV 105he	33.6	105	210	315	420	525	630	735	840
PV 125he	39.8	125	250	375	500	625	750	875	1000

Condensing Outputs @ 50/30°C flow/return temperatures

Boiler Model	Min output kW	Heat output according to number of modules installed - kW							
		1	2	3	4	5	6	7	8
PV 70c	23.3	70	140	210	280	350	420	490	560
PV 95c	31.7	95	180	285	380	475	570	665	760
PV 110c	36.7	110	220	330	440	550	660	770	880
PV 140c	46.7	140	280	420	560	700	840	980	1120
PV 180c	60.0	180	360	540	720	900	1080	1260	1440

Technical Data he Models

Purewell VariHeat High Efficiency Non Condensing Boilers
Performance and General Data Information - Natural Gas

	Boiler Model	PV65he	PV85he	PV105he	PV125he
Energy	Building regulations - seasonal efficiency (%) gross	86.97	87.34	88.10	87.00
	Boiler output 82/71°C kW Btu/hr x 1000	65.0 222	85.0 290	105.0 358	125.0 426
	Boiler input - (gross) - maximum kW Btu/hr x 1000	80.1 273	107.5 367	128.0 437	154.3 526
	Boiler input (nett) - maximum kW Btu/hr x 1000	72.1 246	96.8 330	118.1 403	139.8 477
	Boiler output minimum 82/71°C kW Btu/hr x 1000	21.5 73	30.1 103	33.6 115	39.8 136
Water	Water content litres	6		9	
	System design flow rate @ 11°C Δt rise l/s	1.41	1.85	2.28	2.71
	Water side pressure loss @ 11°C Δt rise mbar	50	80	192	270
	Minimum flow rate @ 15°C Δt rise l/s	1.04	1.36	1.67	2.00
	Water side pressure loss @ 15°C Δt mbar	28	47	98	149
	Minimum return temperature °C	50			
	Maximum water pressure barg	7			
Gas	Gas flow rate natural gas (G20) m ³ /hr	7.63	10.24	12.49	14.79
	Nominal inlet pressure natural gas (G20) mbar	20			
	Maximum gas inlet pressure natural gas (G20) mbar	25			
Flue	Approx. flue gas volume @ 15°C - 9.3 - 9.8% CO ₂ @ N.T.P m ³ /hr	103.00	123.50	156.00	188.00
	Approx flue gas temperature @ 82/71°C °C	158	190	146	175
	Pressure at flue outlet Pa	100			
Connection	Water flow/return connections inches	R 2"			
	Gas inlet connection pipe thread size inches	R 1"			
	Nominal flue diameter (I/D) mm	100			
Electrics	Electrical supply	230V 50Hz 1Ph			
	Power consumption - maximum modulation W	94.3		207	
	Start current Amp	0.54		0.6	
	Approx shipping weight kg	205		277	
	Noise emission @ 1m - maximum modulation MAX dB (A)	53		65	



Technical Data c Models

Purewell VariHeat Condensing Boilers
Performance and General Data Information - Natural Gas

	Boiler Model	PV70c	PV95c	PV110c	PV140c	PV180c	
Energy	Building regulations - seasonal efficiency (%) gross	95.35	95.62	95.89	95.74	94.63	
	Boiler output 80/60°C	kW 63.5	86.3	98.8	134.4	172.8	
		Btu/hr x 1000 217	294	340	448	590	
	Boiler output 50/30°C	kW 70	95	110	140	180	
		Btu/hr x 1000 239	324	375	478	614	
	Boiler input - (gross) Maximum	kW 72.2	98.4	115.0	151.3	194.6	
		Btu/hr x 1000 246	336	392	516	664	
Boiler input (nett) - Maximum	kW 65.0	88.6	103.5	136.3	175.2		
	Btu/hr x 1000 222	302	353	465	598		
Boiler Output Minimum 80/60°C	kW 21.2	28.8	33.3	44.8	57.6		
	Btu/hr x 1000 72	98	113	153	197		
Boiler Output Minimum 50/30°C	kW 23.3	31.7	36.7	46.7	60.0		
	Btu/hr x 1000 80	108	125	159	205		
Water	Water Content litres	8			11		
	System design flow rate @ 20°C Δt rise	l/s	0.836	1.135	1.314	1.672	2.15
	Water side pressure loss @ 20°C Δt rise	mbar	32	52	72	134	221
	System design flow rate @ 11°C Δt rise	l/s	1.5	2.1	2.4	3.0	3.9
	Water side pressure loss @ 11°C Δt rise	mbar	96	176	244	442	731
	Maximum water pressure	barg	7				
Gas	Gas flow rate natural gas (G20) - maximum	m ³ /hr	6.88	9.375	10.956	14.42	18.541
	Nominal inlet pressure natural gas (G20) - maximum	mbar	20				
	Maximum gas inlet pressure natural gas (G20)	mbar	25				
Flue	Approx. flue gas volume @ 15°C - 9.3 - 9.8% CO ₂ @ N.T.P	m ³ /hr	86.13	117.37	137.16	180.53	232.12
	Approx. flue gas temperature @ 50/30°C	°C	40		45	50	50
	Approx. flue gas temperature @ 80/60°C	°C	60		65	70	75
Connection	Pressure at flue outlet	Pa	100				
	Water flow/return connections	inches	R2"				
	Gas inlet connection pipe thread size	inches	R1"				
Electrics	Nominal flue diameter (I/D)	mm	150				
	Electrical supply		230V 1Ph 50Hz				
	Power consumption - maximum modulation	W	94.3			207	
	Start current	Amp	0.54			0.6	
	Approx shipping weight	kg	170			230	
	Noise emission @ 1m - maximum modulation	MAX dB (A)	53			65	

Dimensional Details he Models

Purewell VariHeat High Efficiency Non Condensing Boilers

Single Boilers Without Pipe Kits

Dimensions in mm	PV65he & PV85he	PV105he & PV125he
Flow connection A	775nom	908nom
Return connection B	401nom	330nom

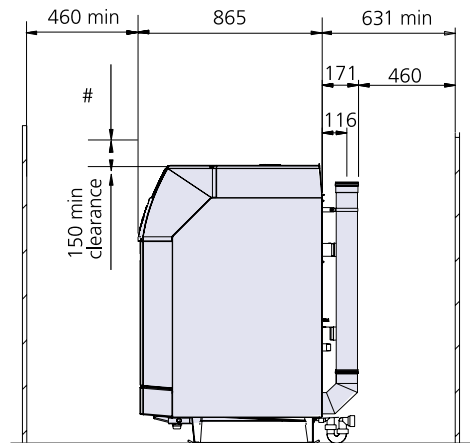
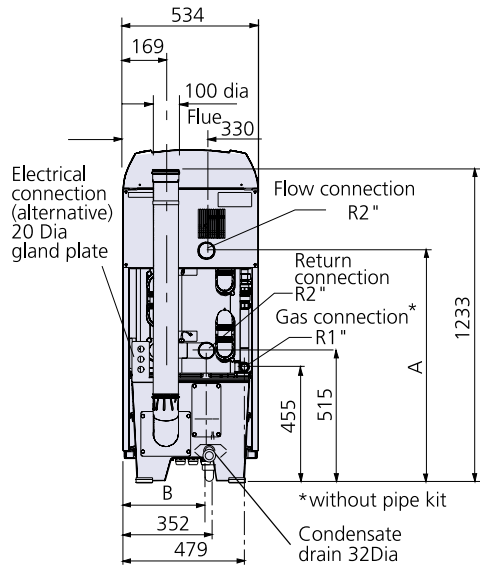

Do not run trunking or pipework across the top of the boiler. Access is required top and front for servicing.

Multiple Boilers With Pipe Kits

Dimensions in mm	PV65he & PV85he	PV105he & PV125he
Flow connection C	1650nom	1780nom
Return connection D	1400nom	1540nom

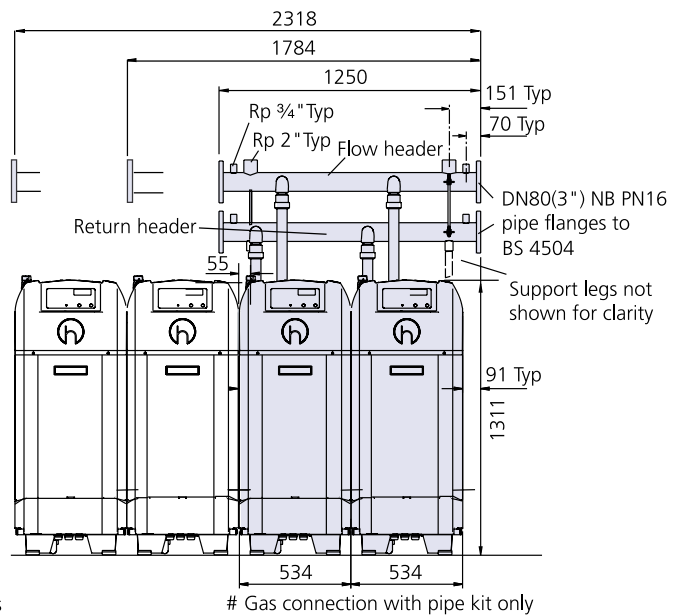
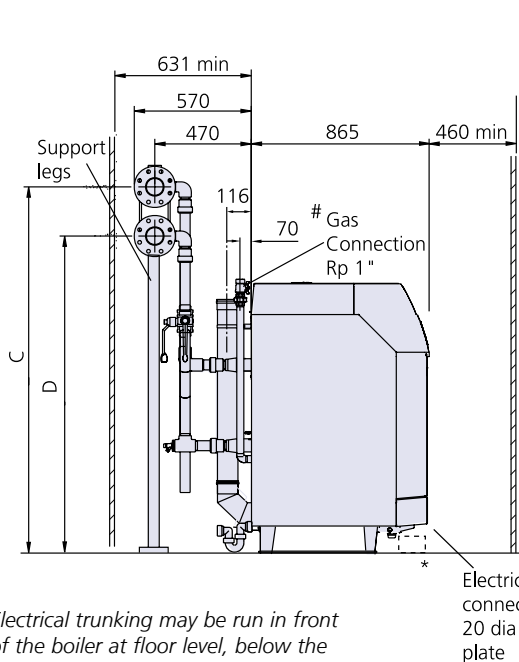

Dimensional Details c Models

Purewell VariHeat Condensing Boilers

Boilers Without Pipe Kits

Dimensions in mm	PV70c, PV95c & PV110c	PV140c & PV180c
Flow connection	A	780

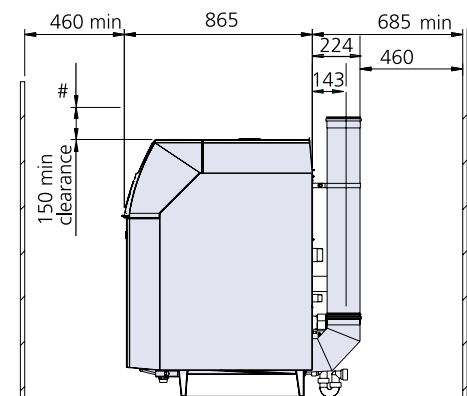
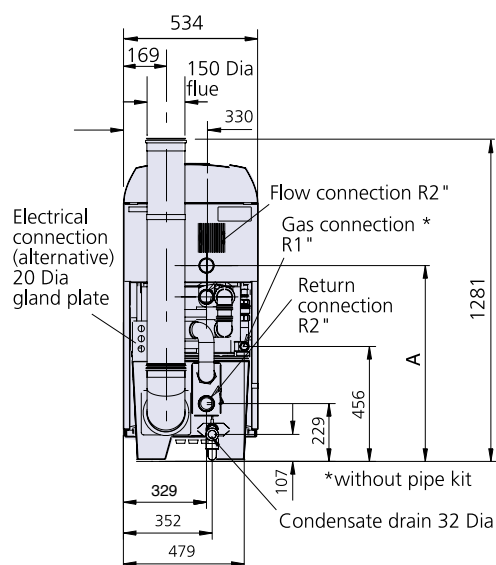

Do not run trunking or pipework across the top of the boiler. Access is required top and front for servicing.

Boilers With Pipe Kits

Dimensions in mm	PV70c, PV95c, PV110c, PV140c	PV180c
Flow connection	C	1700
Clearance	G	631
Header centre line	D	465
Header extremity	E	590
Pipe flange to BS4504	H	DN125 (5")NB PN16

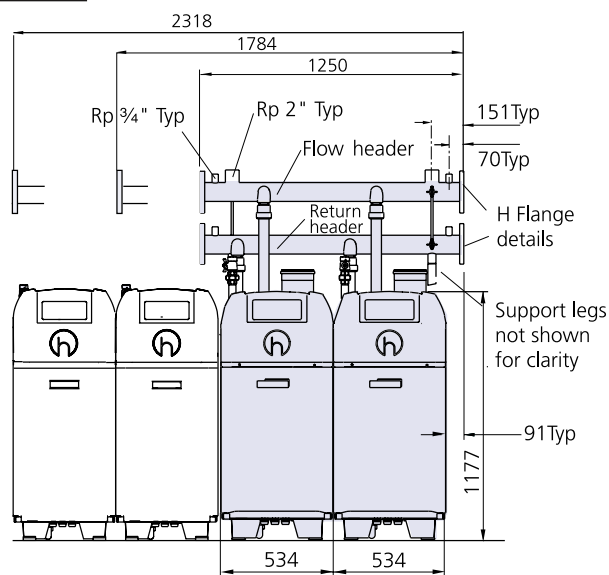
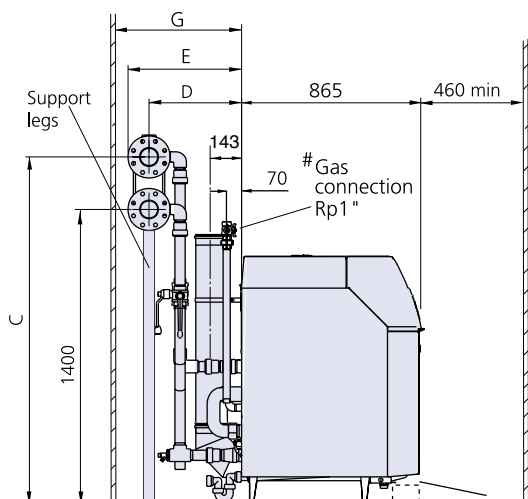

* Electrical trunking may be run in front of the boiler at floor level, below the front cover. (not HHL supply).

Electrical connections 20 Dia gland plate

Gas connection with pipe kit only

Controls Overview

Purewell VariHeat

Purewell VariHeat boilers can be installed in a wide variety of configurations, from single boiler stand alone units to multiple boilers controlled locally or by a building management system. The controls package is extremely versatile and can be tailored to meet the exact needs of the heating system.

Integrated Systems

The full benefits of installing high efficiency boilers can only be realised if the heating system is equipped with appropriate controls, that integrate the boiler and the other system components, to create a cohesive solution. For that reason, the Purewell VariHeat range of boilers incorporate a control system that is easy to integrate and communicates with the leading building management system protocols. The microprocessor based boiler control system (LMU) accommodates clip-in modules providing relay contacts for remote alarm and signalling, for external control and LPB bus communications, for use with the boiler Cascade controller for multiple boiler installations.



Clip in modules on the LMU

The Purewell VariHeat boiler incorporates a number of inbuilt and optional controls features that enable the end user to achieve desired operational mode whilst maintaining the optimum efficiency of the system.

The controls are housed within a fabricated steel enclosure, and each module fascia features a visual display allowing the user to monitor the current operating status of the boiler. The panel also displays comprehensive fault code information in the unlikely event of a boiler lockout.

Volt Free Contacts

All Purewell VariHeat modules are fitted with a multi-function clip-in module to provide volt free contacts as standard. Remote alarm signalling is provided for a general fault alarm and boiler normal run indication.

0-10 Volt DC Analog Input

The standard multi-function clip-in module also provides a 0-10 volt DC analog signal interface to control the modulation level of the burner, or to set the flow temperature set point. The 0-10 volt signal can be used for remote connection of the boilers to a Building Management System, (BMS) to enable modulating control remotely.

LPB Bus Communications Module

The optional LPB bus communication clip-in kit is used to connect the boiler LMU control unit to the optional Cascade sequence control module. Each boiler in a modular installation requires a clip-in LPB bus communications module to communicate with the Cascade controller.

Outside Air Temperature Sensor

Purewell VariHeat boilers can be supplied with an optional outside temperature sensor to exploit the full functionality of the boiler controls and enable direct temperature compensation on the boiler, maximising the condensing operating conditions. The outside temperature sensor is to be used in conjunction with the optional Cascade control module.

When fitted with an outside temperature sensor, the boiler's own thermostat is overridden and the flow temperature is controlled as a function of external temperature conditions. The flow temperature is adjusted according to a preset heating curve built into the standard boiler controls. This slope can be adjusted to suit the needs of individual systems by for example using a steeper slope on underfloor heating systems.

Programmable Room Sensor

An optional combined room sensor and digital programmer can be connected to the boiler to provide both temperature control of ambient conditions and to programme up to three daily periods for heating or hot water.

Note: An outside sensor must be used when using the room sensor and programmer. Separate ambient temperatures can be set for each time period with an override facility, enabling the user to switch the system either on or off at their request. The programmer will display the current system operating parameters and also indicate any boiler fault conditions that might occur.

Frost Protection

The boiler control system features a two stage frost protection system. When the boiler is not operating, the frost protection system fires the boiler to maintain a minimum water temperature, to prevent freezing of the heating system water.

Additionally, if an external temperature sensor is connected, the circulation pump will be run intermittently when the outside temperature falls below 1.5°C.

Cascade Control Module

For use with multiple boilers, the optional Cascade controller can sequence up to 12 modules. The controller is supplied with two clip-in LPB bus communications modules as part of the standard Cascade kit, and for each additional boiler in the modular installation, further clip-in LPB bus communications modules must be ordered separately. (IE: A four module installation with a Cascade control kit requires two additional LPB modules).

Control Details

Purewell VariHeat Single Boiler Installations

On Purewell VariHeat boilers, the control options for single boilers are different to those for multiple boilers.

Please refer to page 12 for controls on multiple boilers.

All controls functions are managed via the 'boiler management unit' Siemens LMU64. Using a combination of options, the level of control is expandable for up to 2 heating circuits and 1 domestic hot water cylinder.

A circulation pump overrun timer is incorporated within the boiler LMU.

Programmable Room Sensor

A single boiler Purewell VariHeat system can be fitted with a single programmable room sensor, which should be located in the first heating zone. This room thermostat allows heating circuit management to be based on both the internal and external air temperature. The boiler will manage the heating circuit pump via a contactor according to the program requirements of the programmable room unit.

Features:

- Individual 7 day program with auto summer / winter hour change for heating circuit 1, heating circuit 2 and DHW
- 3 periods per day per time program
- Constant or variable temperature flow
- Compensated flow temperature based on external and room air temperatures
- Optimised start / stop based on external and room air temperatures
- Building frost protection based on room air temperature
- Summer shutdown based on outside air temperature
- Holiday period with frost protection
- Reduced temperature, night set back for non occupancy hours
- Pump kick for pumps controlled from boiler
- Programme lock to prevent tampering
- Individual temperature settings for each zone

To achieve full functionality an outside air sensor must be fitted.

Options for a single Boiler only

- **Programmable room sensor (QAA73)**
- **Outside air sensor (QAC34)**
- **2nd Heating Circuit Clip-in relay kit (AGU2.500)**
- **DHW Cylinder Sensor Kit (QAZ21)**

Outside Air Sensor

An optional outside air temperature sensor may be wired directly to the boiler to exploit the direct weather compensation functionality of the boiler controls. This sensor may be connected to the control scheme and should ideally be positioned on an external wall with northerly aspect.

2nd Heating Circuit Clip-in Relay Kit

To control a second heating circuit, an additional clip-in relay kit is required for fitting directly to LMU. The kit comprises a relay and water temperature sensor complete with pocket.

This kit provides outputs for a pump and mixing valve.

- Mixing valve allows second heating circuit to operate at a different temperature set-point to heating circuit 1.
- Second heating circuit should operate at the same or lower temperature than circuit 1, e.g. underfloor heating.
- Programmed via QAA73 programmable room sensor
- Compensated flow based on outside air temp and using a curve separate to that of heating circuit 1 owing to mixing valve
- Optimised start/stop based on outside air temp
- Frost protection based on water temperature in second heating circuit

For the second heating circuit, the boiler will manage the circuit pump and/or mixing valve via contactors, according to the program requirements of the programmable room sensor and the water temperature sensor. Only one programmable room sensor may be connected, therefore the second heating circuit management is derived from time control and external air temperature measurement.

DHW Cylinder Sensor Kit

This kit is for a domestic hot water (DHW) circuit directly controlled from the boiler, but programmed via the QAA73 programmable room sensor, and features:

- Immersion sensor complete with pocket
- DHW cylinder sensor and pump output directly from boiler LMU
- Frost protection based on stored water temperature
- Reduced storage temperature for non-occupancy hours
- Anti-Legionella function

For the DHW cylinder circuit, the boiler will manage the primary coil pump according to the program requirements of the programmable room unit and the DHW cylinder sensor.

Control Details

Purewell VariHeat Multiple Boiler Installations

On Purewell VariHeat boilers, the control options for multiple boilers are different to those for single boilers.

Please refer to page 11 for controls on a single boiler.

The Purewell VariHeat boiler in a multiple boiler installation may be controlled by a boiler sequencing cascade controller. This provides cascade control from either external enable signals or from internal time clock settings. Up to 12 boiler modules may be controlled and communication between the cascade controller and boilers is via an LPB bus.

The boiler sequencing cascade controller is a sophisticated controller which, when used with a room temperature sensor and outside air sensor, will provide enhanced comfort control for the heating zone it is connected to.

Additionally a domestic hot water cylinder circuit may also be controlled from the boiler cascade controller.

Where the building has more than one heating zone, additional zone controllers can be added to provide a comprehensive building heating control.

Programmable Room Sensor

The programmable room sensor communicates room temperature to the RVA47 Cascade Controller and allows the user full adjustment of the room temperature, time clock, holiday periods and frost protection settings. The unit also displays fault codes from the boiler plant. Alternatively, non adjustable and offset adjustable room sensors are also available, for installations requiring users to have less access to system settings.

Features:

- 3 programmable periods per day
- Reduced temperature/night set back for non occupancy hours
- Holiday period. Frost protection remains active
- Programme lock to prevent tampering
- Indication of operating parameters and boiler fault condition
- 7 day time clock with automatic summer/winter clock adjustment

Options for Multiple Boilers only

- **Boiler sequencing cascade controller (RVA47)**
- **LPB bus communications Clip-in module (OCI420)**
- **Programmable room sensor (QAA70)**
- **Outside air sensor (QAC31)**
- **Room sensor non-adjustable (QAA10)**
- **Room sensor offset adjustable (QAA50)**
- **Zone controller (RVA46)**
- **DHW Cylinder Sensor Kit (QAZ21)**

LPB Bus Communications Clip-in Module

1 clip-in module is required for every boiler in a multiple boiler arrangement. Two clip-in modules are supplied as part of the Boiler Sequencing Cascade Controller kit, so for three boilers or more, additional clip-in modules must be ordered.

Boiler Sequencing Cascade Controller

Multiple Purewell VariHeat boilers can be sequenced using this cascade control kit. The kit includes:

- RVA47 controller
- Insertion type water temperature sensor with pocket
- Two clip-in LPB bus communication modules*

** Note: When controlling more than two boilers, then additional clip-in LPB bus communication modules must be ordered separately. (I.e. A four boiler installation with a cascade control kit requires two additional LPB bus communication clip-in modules)*

Features:

- Provides cascade control from either external enable signals, 0-10v analogue heat demand signal or built-in time clock setting
- Up to 12 boilers may be sequenced
- Lead boiler rotation
- 7 day time clock with automatic summer/winter clock adjustment
- 3 programmable periods per day
- Constant or variable temperature flow
- Compensated flow temperature based on external and room air temperatures
- Optimised start and stop based on external and room air temperatures
- Frost protection based on boiler water temperature
- Building frost protection based on room air temperature
- Summer shutdown based on outside air temperature
- Holiday period. Frost protection remains active
- Reduced temperature/night set back for non occupancy hours
- Pump kick for pumps controlled from boiler
- RVA47 controller is designed for mounting in a remote panel (not HHL supply)

To achieve full functionality an outside air sensor must be fitted.

The boiler cascade will operate according to the integral seven day time clock with automatic summer/winter hour change. Three time periods are programmable for each day. When there is no time demand, the boiler will revert to the reduced temperature / night set back set-point, provided a room temperature sensor is fitted. Otherwise the cascade will not operate unless the frost protection function of the boiler and/or cascade is activated.

Outside Air Sensor

To be used with cascade controller, the optional outside temperature sensor must be wired directly to the cascade controller to exploit the full control functionality, including weather compensation.

This sensor must be connected to the control scheme and must be positioned on an external wall with northerly aspect.

Room Sensor Non Adjustable

For installations where controls are not to be adjusted by the building occupants, the QAA10 non adjustable room sensor may be used. This prevents tampering and communicates room temperature to RVA47 Cascade Controller. No user adjustment is possible.

Room Sensor Offset Adjustable

For installations where limited control is required by the building occupants, the QAA50 offset adjustable room sensor may be used. This permits adjustment +/- 3°C from the programmed temperature set point and communicates room temperature to RVA47 Cascade Controller.

Zone Controller

Multiple heating zones may be connected into the system to provide a comprehensive building control.

A zone controller and sensors are required for each zone.

Control Features:

- 3 programmable periods per day
- Optimised start / stop
- Constant or variable temperature
- Pump output to control zone pump via relay/contactor (not HHL supply)
- Mixing valve output
- Reduced temperature/night set back for non occupancy hours
- Frost protection
- 7 day time clock with automatic summer/winter clock adjustment

Zone Control

Additional to the cascade control, multiple heating zones can be connected into the system to provide a comprehensive building control. Each zone has an individual 3 program timer, which together with outside and inside air temperature sensors can provide optimised start/stop for that circuit.

Using the RVA46 controller, zones can be configured for either constant temperature or variable temperature. Heat demand is calculated according to zone air temperature and where applicable outside air temperature. Using the same compensation heat curves and parallel displacement curves as the cascade controller (shown on page 15), each zone can be configured to operate individually from any other zone in the system. Individual night set back and frost protection settings as well as summer shut down settings can also be programmed.

Demands for heat are communicated to the cascade controller via the LPB bus to initiate heat generation when required. The cascade will set the primary circuit operating temperature according to the highest heat demand, therefore where multiple heating zones are used, these are best configured as variable temperature circuits making use of the zone controller mixing valve outputs. This way, when differing heat requirements exist across multiple zones, the lower temperature zones can modulate the mixing valve to maintain water temperature requirements.

Each zone control has a pump output that can be used to control the zone pump via a relay/contactor. When a heat demand exists within the zone, the pump will be started until the demand for heat is satisfied.

An individual room air temperature sensor is required in each zone. The same selection of room temperature

sensors are used as for the cascade controller. External air temperature is communicated via the LPB from the sensor connected to the cascade controller.

Each zone controller also has a DHW time program which can be used to initiate the cascade controller for hot water production. Using the same cylinder as the cascade circuit, the cascade will produce hot water whenever there is a hot water demand from one of the zones or from the cascade controller integral hot water time program providing a central hot water facility.

Domestic Hot Water

A domestic hot water cylinder may be connected to the cascade controller. With the immersion temperature sensor connected directly to the cascade controller, hot water will be produced whenever there is a demand within the timer programmed periods.

The hot water circuit is provided with its own three period time clock, and also has a separate night set back feature, frost protection and an anti legionella function.

The primary circuit to the calorifier is controlled using the domestic hot water pump output which is energised only when a hot water demand is present. This pump should be connected to the controller via a relay contactor.

Multiple Boilers

With Modulating Burners

Optimising Life Time Performance

In addition to providing system security, accurate load matching is one of the major advantages of using multiple boilers.

When first introduced, modular boilers operated in a basic mode, where modules were switched on or off to meet the system demand for heat. The requirement for turndown was met by increasing or decreasing the number of modules (boilers) in an installation.

As boiler designs advanced, two stage modular boilers became more popular, and high/low firing boilers changed the parameters for turndown.

Today, most high efficiency boilers have fully modulating capability and this once again changes the methodology for achieving close control in a multiple boiler installation.

When selecting modulating high efficiency boilers, consideration should be given to the life time costs associated with service and maintenance of the boilers. Opt for too many small output (kW) boilers and the servicing costs will be higher, whereas too few large output (kW) boilers will result in less back up and system security.

It is important therefore to select the optimum size boiler output and number of modules to achieve a balanced life time cost and ensure system security.

The Hamworthy range of Purewell VariHeat boilers has been designed to satisfy a wide range of commercial systems. Available as condensing and non-condensing boilers, with fully modulating burners, multiple boiler applications enable accurate load matching using the optimum number of boiler modules.

Each module (boiler) can modulate to part load conditions, where efficiency performance will be the greatest.

Setting the boiler sequence controller to fire each boiler at low fire before modulating up to high fire will not only provide the best efficiency performance, but also enable the boilers to share the system load and even out wear and tear on the plant.

In practice, heating systems rarely operate at full load conditions and so configuring the system to optimise the part load performance is an effective way of maximising the energy saving of the heating plant.

Purewell VariHeat Boiler Sequencing Cascade Controller

The boiler sequencing cascade controller available with Purewell VariHeat boilers can be configured to sequence boilers in traditional cascade mode or in unison mode.

Cascade Control

Steps a boiler module on at its lowest rate and then modulates it to its maximum rate, before switching on the next boiler module at its lowest rate, to match the system load. Maintains the lowest number of boiler modules in operation for a given heat load.

Unison Control

Steps each boiler module on in turn at its lowest rate, then modulates all boiler modules simultaneously to higher rates to match the system load. This method of sequencing can offer higher operating efficiencies, taking advantage of the higher part load efficiencies available at low firing rates.

Using BMS Signals to Initiate Cascade

Temperature control 0 -10 Volt DC analog input.

The cascade controller can be configured to accept a BMS analog input to initiate heat generation. Where analog inputs are used, the cascade controller provides heat generation according to the magnitude of the input signal only. NOTE: When using the BMS to initiate cascade control via a 0-10 volt analogue signal, then the internal time clock and remote enable circuit functions are disabled. Input signals to the RVA47 cascade control must be temperature configured. The input signal is translated to a temperature set-point for the flow temperature, and translation is according to a linear graph from 5°C to an upper limit set by parameters during commissioning. 10 Volts corresponds with the upper limit with a maximum 90°C setting.

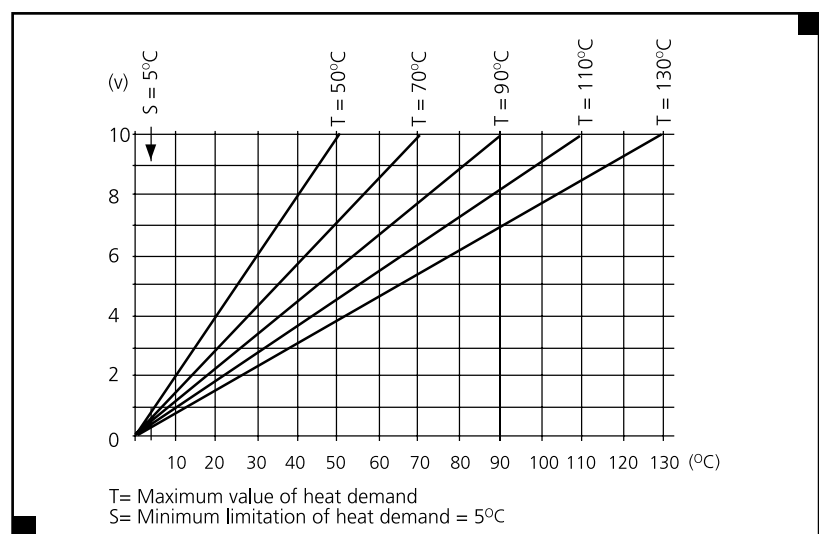

When there is no analog input, the boilers will not fire unless the frost protection function of the boiler is activated. It is recommended that the BMS has a frost protection setting higher than 5°C water temperature, to prevent the boiler from firing without circulation. *Please refer to the section on pump control, page 15.* Whilst operating with an analog input signal, the cascade controller will provide lead boiler rotation programmable for number of hours run.

Weather Compensation

When using an external air temperature sensor with remote enabled systems (not 0 – 10 Volt) or integral time clock, the flow temperature can be directly compensated. The heating curve corresponding to the required flow temperature conditions is fully adjustable with curve settings from 2.5 to 40.

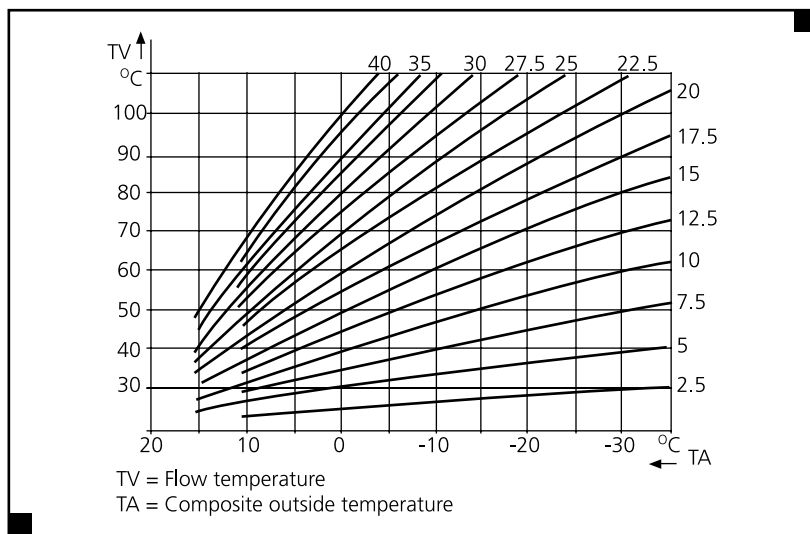

To further enhance comfort levels within the building, when used in conjunction with a room temperature sensor, the cascade flow temperature set-point will be adjusted, dependent on the actual room temperature. I.e. if the room temperature is high then the control will further reduce the flow temperature automatically.

Further enhancements for comfort can be made using the offset adjustment for the heating curve, programmable to reset the curve parallel to the original +/- 4.5°C

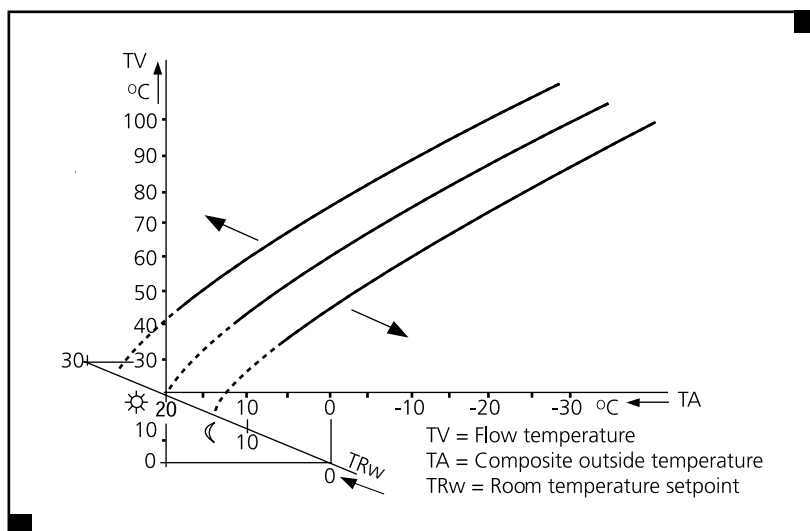

Room Temperature Set Point

The required room temperature is set from the cascade controller and the actual room temperature communicated to the cascade controller from a remote room temperature sensor.

Primary Circuit Pump Control

In all installations it is recommended that the primary circuit pump start signal is provided from the boilers. Each boiler has a shunt pump output and these should all be wired together in parallel to energise the pump relay contactor. It is important that all boilers are connected to the same supply phase, as mixing phases could lead to higher voltages present in the pump circuit than required. By energising the primary pump via the boilers, the boilers are prevented from firing without circulation, in frost protection mode.

Should control of the primary pump be required from an alternative source, such as a BMS system, then the frost protection set point for starting the primary pump should be higher than 5°C water temperature.

This will ensure that the primary pump will have started before the boilers can operate under the influence of their integral frost protection, which is set at 5°C water temperature.

Interlocks

Remote interlocks, e.g. pressurisation unit, flue fans etc can be connected directly to each boiler module using the safety interlock circuit input. Neither the RVA47 cascade controller nor the RVA46 zone controller have safety interlock circuit inputs.

Remote Start Stop

The RVA47 Cascade controller can receive a remote start stop signal from an external source. This signal must be via a volt free contact. All time clock functions including optimised start and stop must be incorporated within the remote time clock circuitry. The frost protection functionality within the RVA47 Cascade controller will always remain active.

Controls Scheme 1

Purewell VariHeat Boilers
Internal Time Clock Controlled System using RVA47

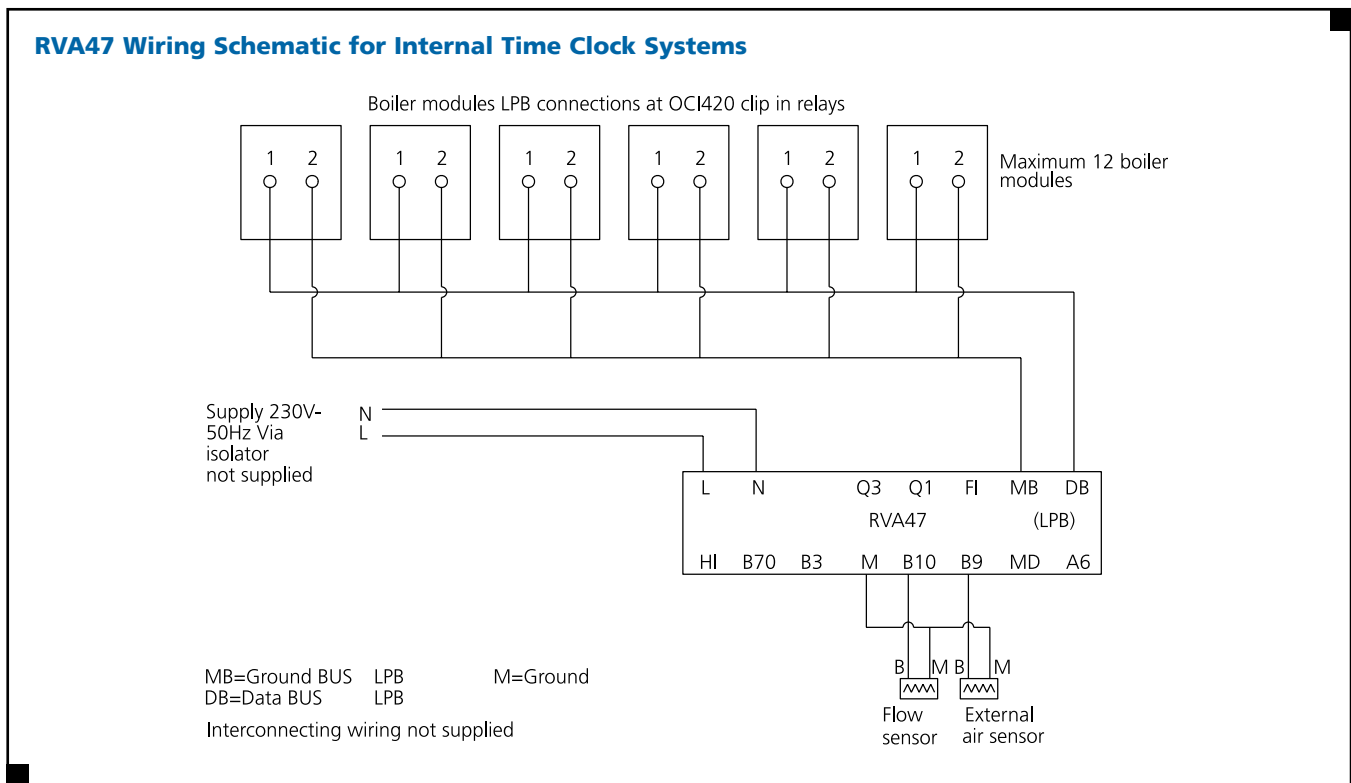
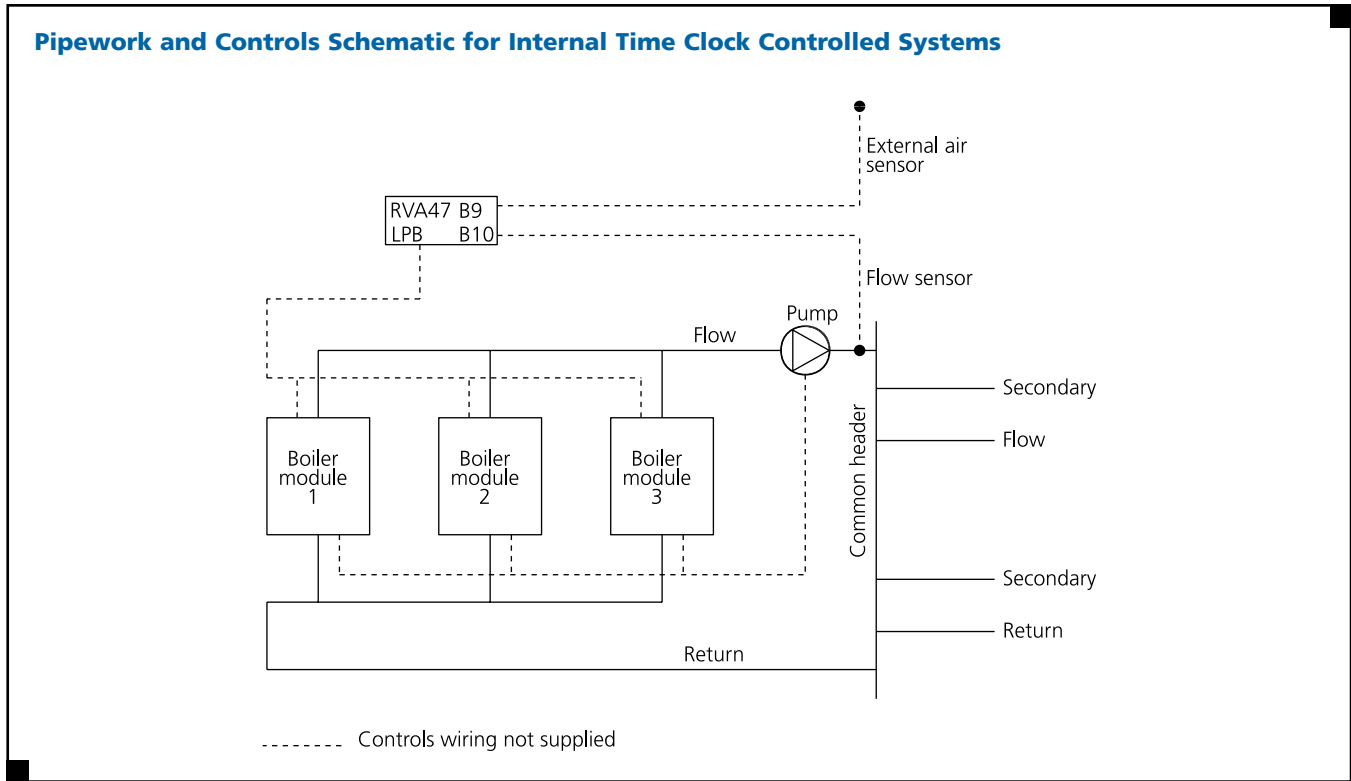

These schematics are available to download at www.hamworthy-heating.com

Controls Scheme 2

Purewell VariHeat Boilers
External Switched Remote Enable with RVA47

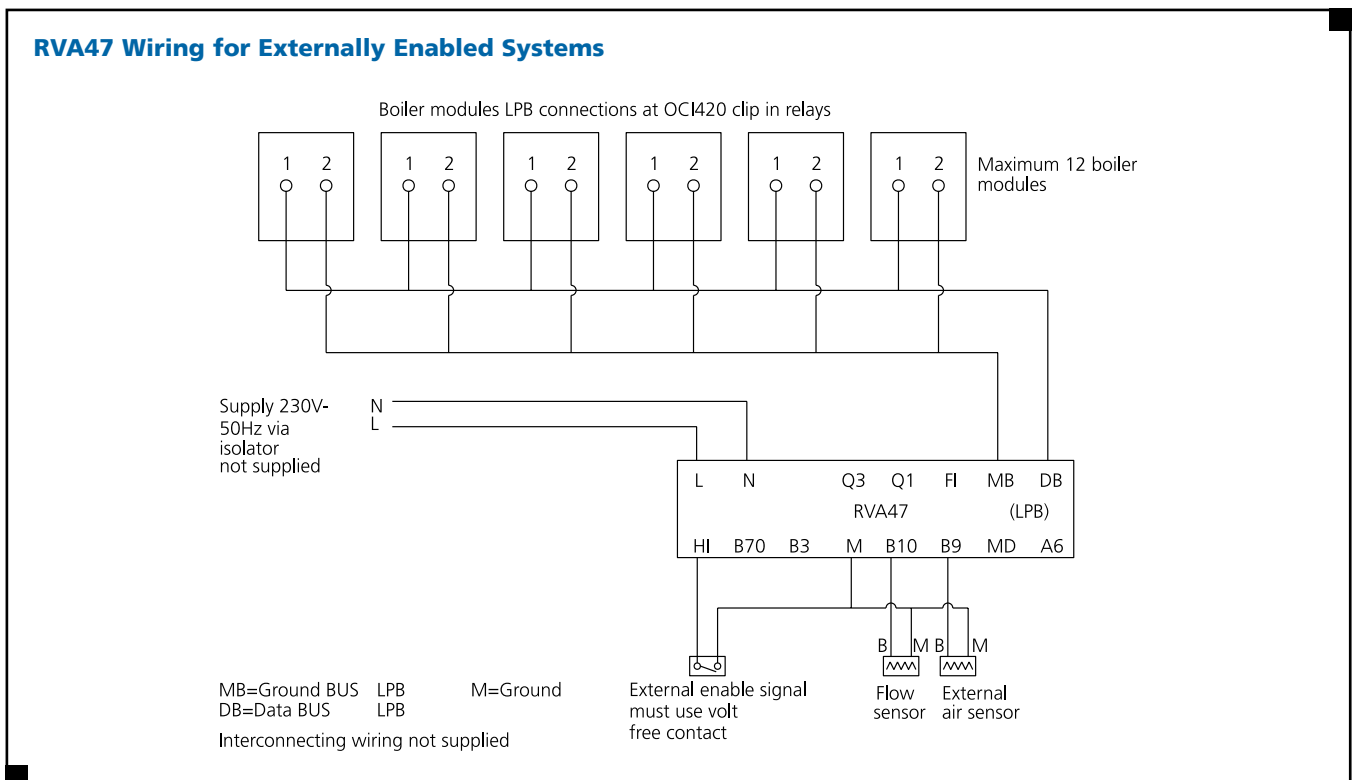
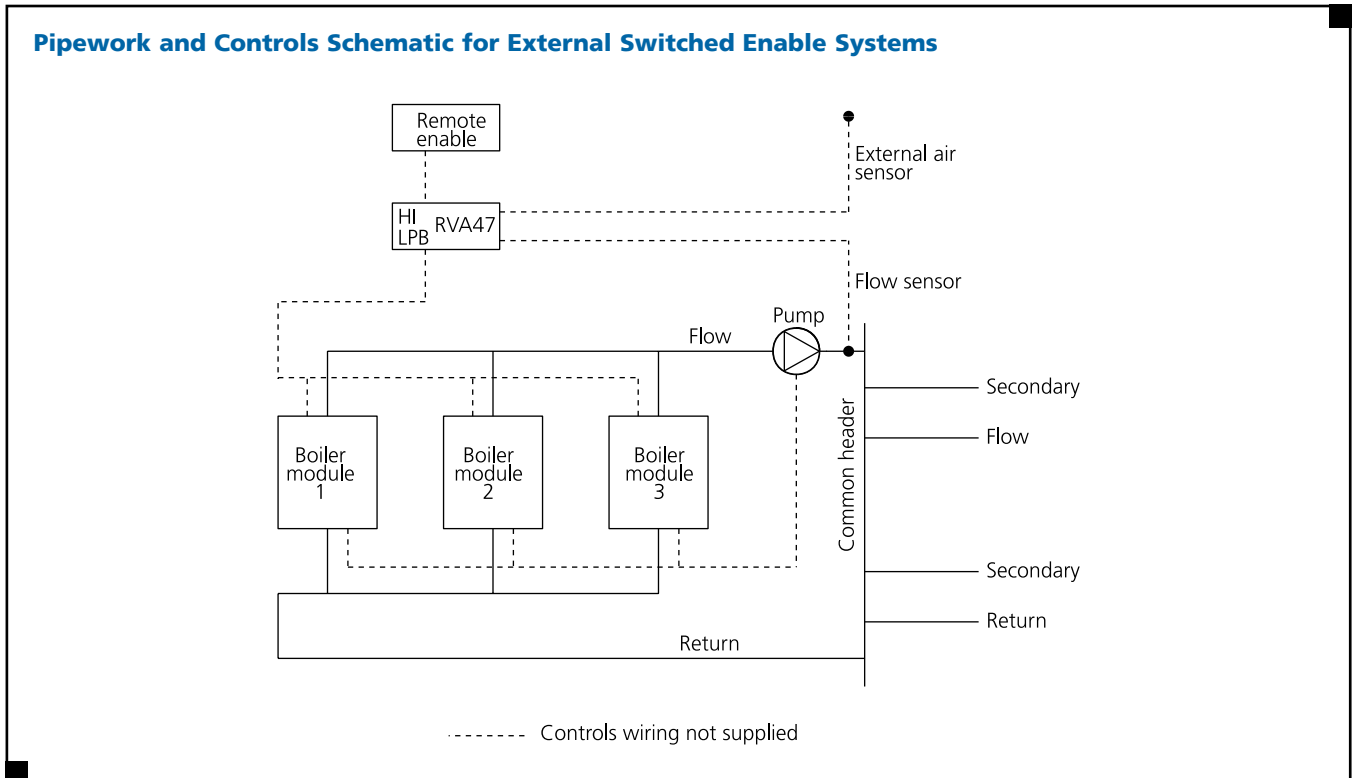

These schematics are available to download at www.hamworthy-heating.com

Controls Scheme 3

Purewell VariHeat Boilers
External 0-10 volt Enabled System with RVA47

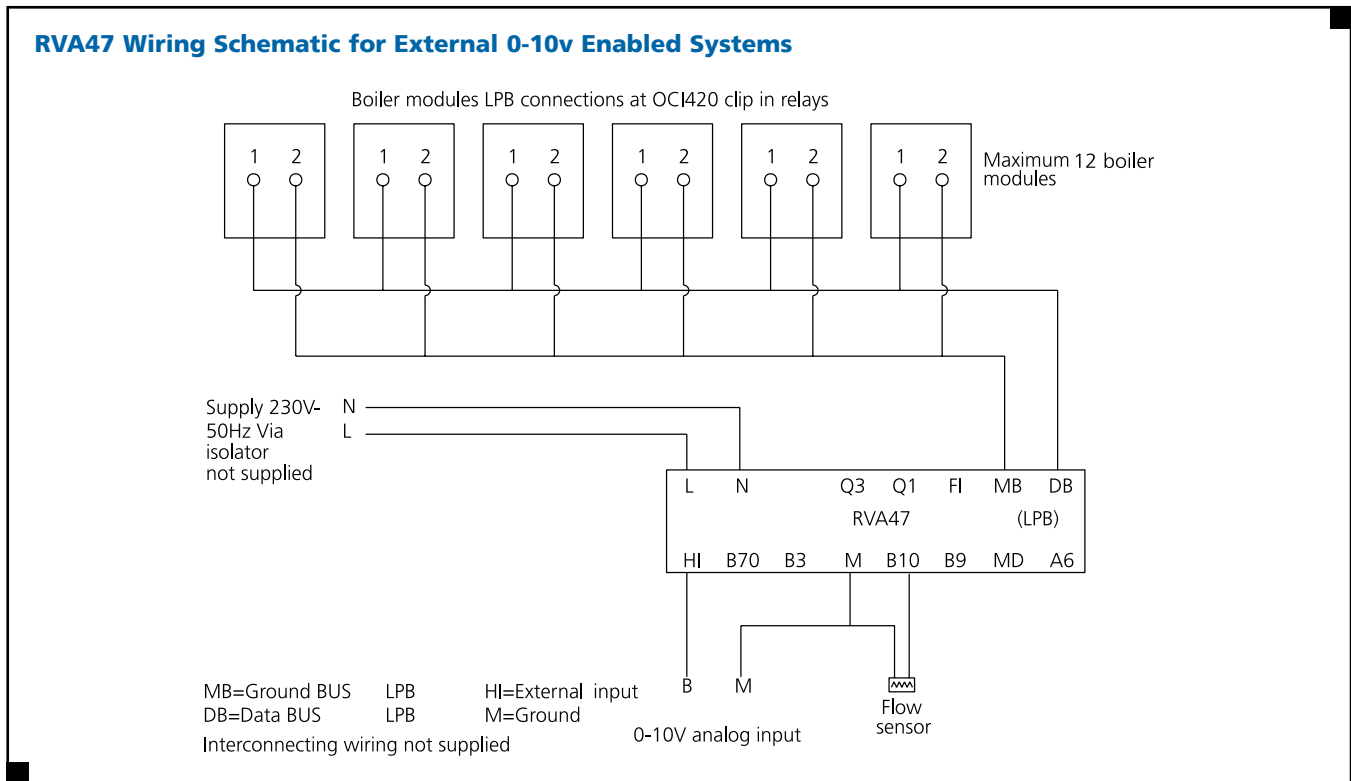
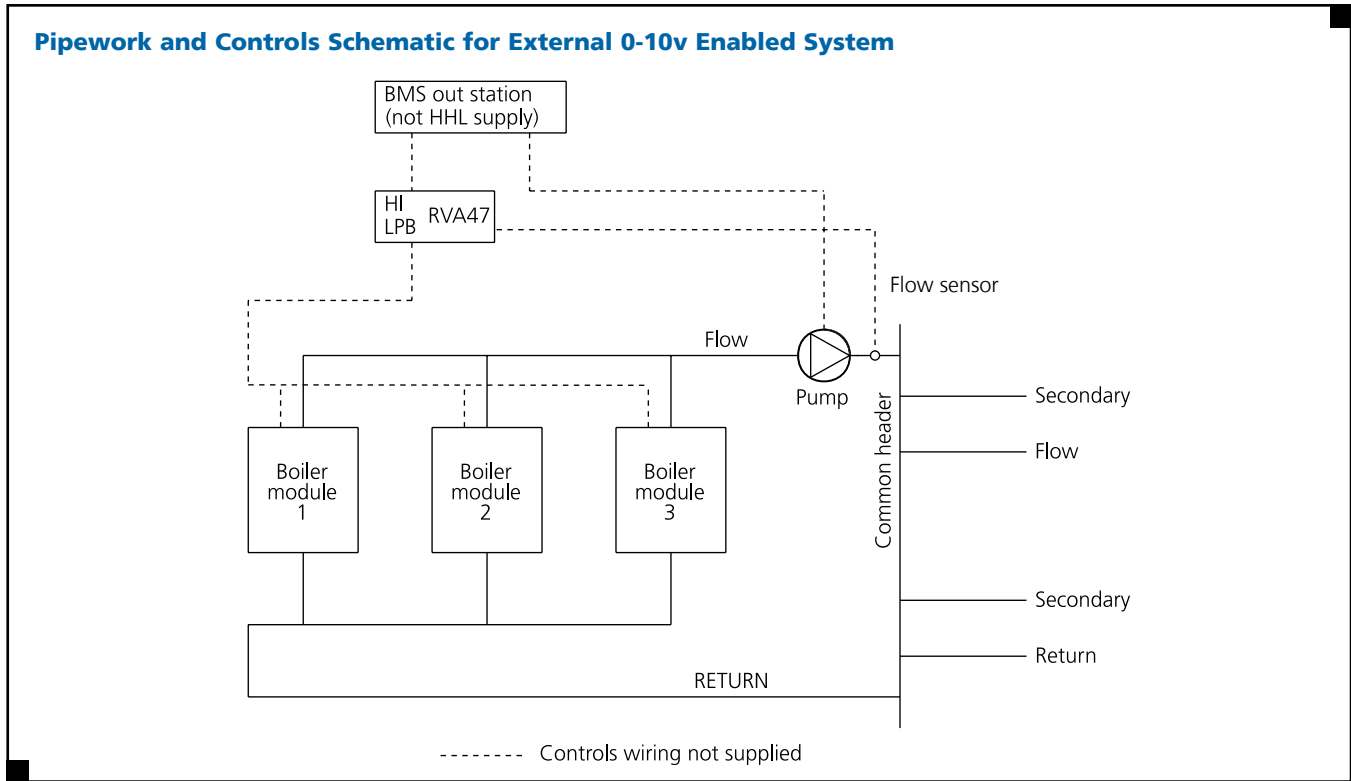

These schematics are available to download at www.hamworthy-heating.com

Controls Scheme 4

Purewell VariHeat Boilers

RVA47 Control of Primary Circuit, Time Control of Secondary Circuits using RVA46

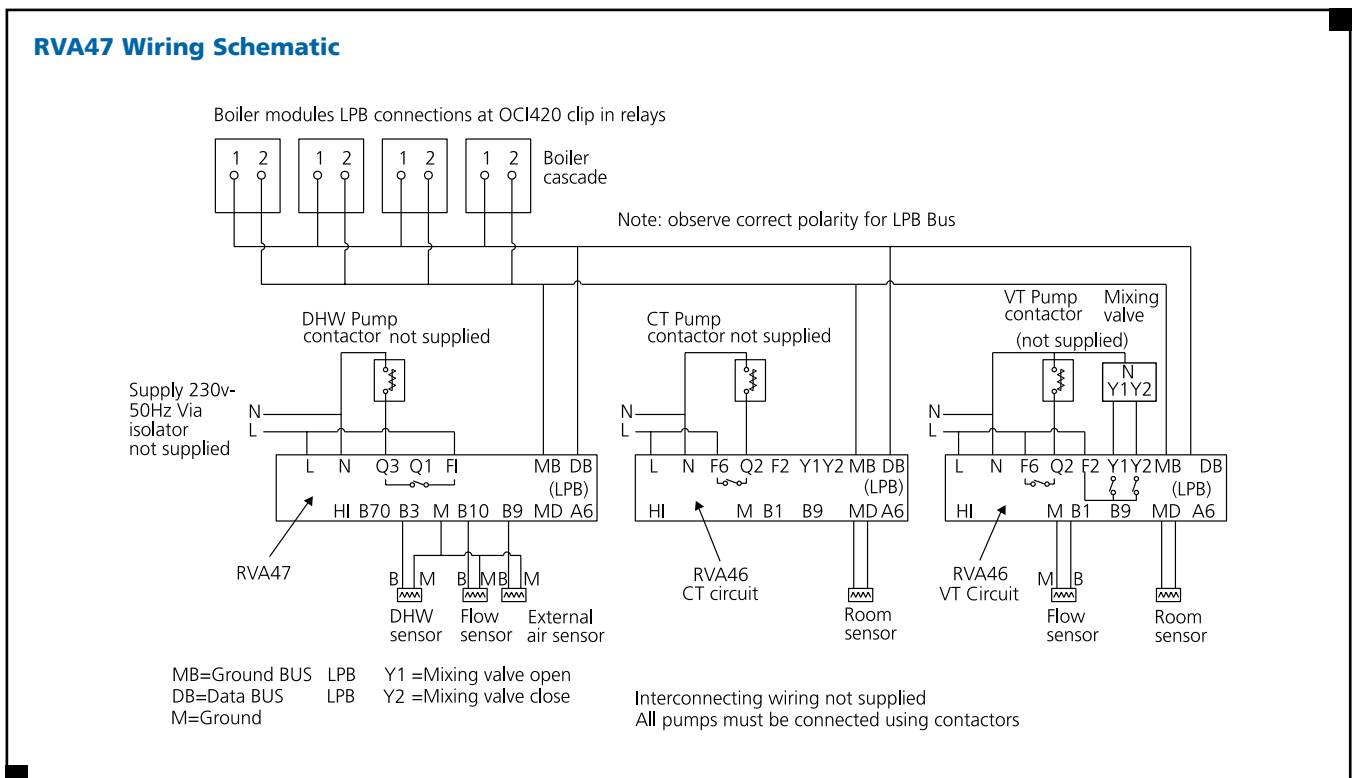
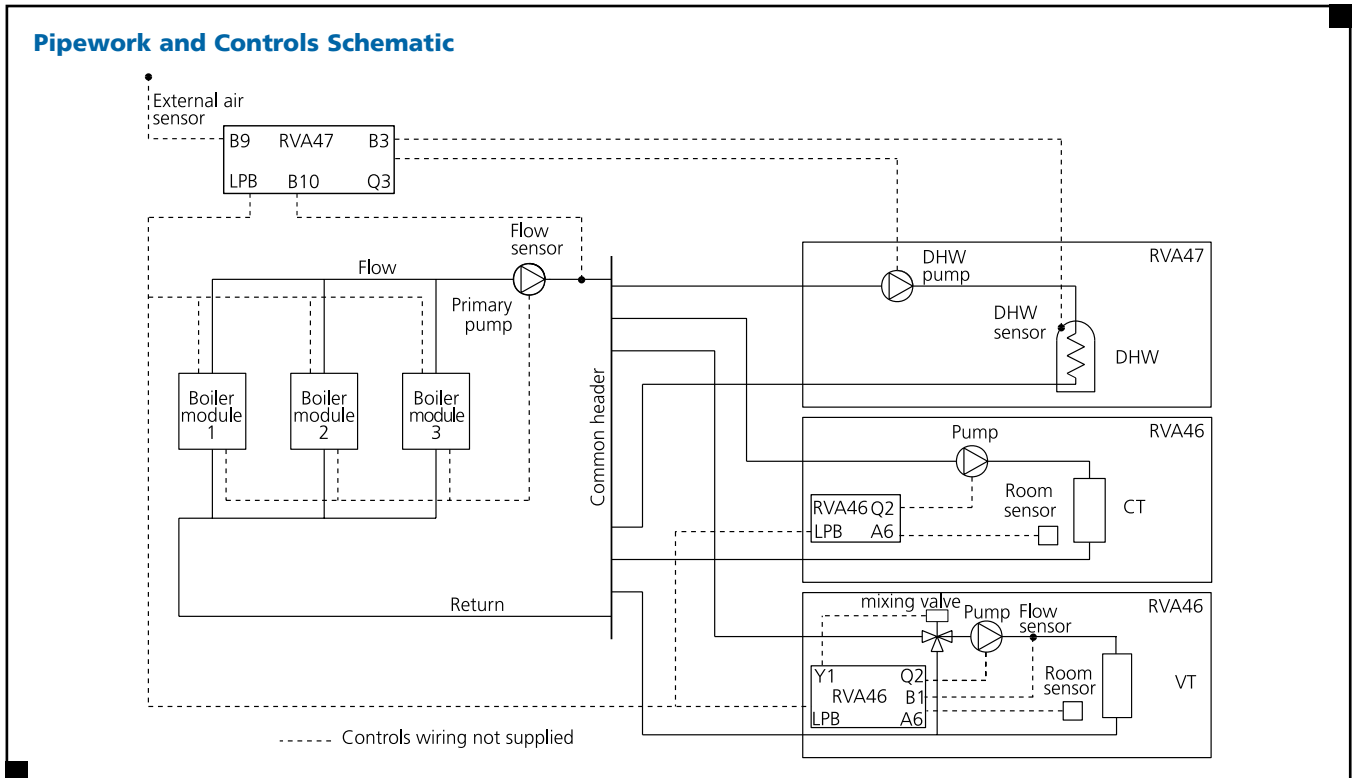

Application & System Data

Purewell VariHeat Boilers

The installation of the boiler MUST be in accordance with the relevant requirements of the Gas Safety Regulations, Building Regulations, IEE Regulations and the bylaws of the local water undertaking. It should also be in accordance with any relevant requirements of the local gas region and local authority and the relevant recommendations of the documents below.

The following British Standard Codes of Practice and Regulations have relevant recommendations regarding the installation of Purewell VariHeat boilers.

British Standards

BS 5440.Part 1 Installation and maintenance of flues for gas appliances of rated input not exceeding 70kW net.

BS 5440.Part 2 Installation and maintenance of ventilation for gas appliances of rated input not exceeding 70kW net.

BS EN ISO 4126-1 Safety devices for protection against excessive pressure. Safety valves.

BS 6798 Installation of gas appliances rated input not exceeding 70kW net.

BS 6644 Installation of Gas Fired Hot Water Boilers, 70kW to 1.8MW net input.

BS 6700 Design, installation, testing and maintenance of services supplying water for domestic use.

BS EN 806-2 Specification for installations inside buildings conveying water for human consumption – Part 2: Design.

BS 6880 Part 1,2 & 3 Code of practice for low temperature hot water heating systems of output greater than 45kW

BS 7074 Part 1 Application, selection and installation of expansion vessels and ancillary equipment for sealed water systems.

Part 2 Code of practice for low and medium temperature hot water systems.

BS 7671 Requirements for electrical installations. IEE Wiring Regulations. Sixteenth edition.

I. Gas E. Publications

IGE/UP/1 Soundness testing and purging of industrial and commercial gas installations.

IGE/UP/1A Soundness testing and direct purging of small low pressure industrial and commercial natural gas installations.

IGE/UP/2 Gas installation pipework, boosters and compressors in industrial and commercial premises.

IGE/UP/10 Installation of gas appliances in industrial and commercial premises, Part 1 flued appliances.

Health and Safety Executive:

Guidance note PM5 - Automatically controlled steam and hot water boilers.

CIBSE Publications

CIBSE Guide B Heating, ventilating, air conditioning and refrigeration.

CIBSE Guide H Building Control Systems

CIBSE Guide Energy Efficiency in Buildings

CIBSE Commissioning Code B: 2002

Dept. of the Environment, Scottish Development Dept. & Welsh Office.

1956 Clean Air Act Memorandum Third edition

Third Edition of the 1956 Clean Air Act Memorandum.

Department of the Environment, Scottish Development Department & Welsh Office.

Location

The location chosen for the boiler must permit the provision of a satisfactory flue system and an adequate air supply. The location must also provide adequate space for servicing and air circulation around each unit.

This includes any electrical trunking laid along the floor and to the appliance.

Any combustible material adjacent to the boiler and the flue system must be so placed or shielded to ensure that its temperature does not exceed 65°C. Further details regarding boiler location are given in BS 6644. & BS 5440 part 2.

Purewell VariHeat boilers should be positioned on a level non combustible surface that is capable of supporting the boiler weight when filled with water, plus any ancillary equipment. Adequate space should be allowed for installation and servicing. *Refer to dimensional drawings on pages 8 & 9 for more details.*

Adequate Water Flow

The Purewell VariHeat boiler is designed as a quick response, low water content unit to run continuously with minimal operating problems. Care should be taken in the initial design and layout, having due regard for adequate water flow through the boilers, and the influence of the control system. Hamworthy strongly recommend that Purewell VariHeat boilers are installed using the primary circuit design to ensure adequate water flow regardless of secondary circuit operating conditions. Refer to technical data tables for minimum water flow requirements.

The control system and valves, where fitted, should be regulated to avoid lower flows occurring. Condensing models are designed to operate with systems operating at 20°C differential temperatures and return temperatures as low as 30°C. Increased flow rates may be used for lower temperature differentials with due regard for the increased pressure loss through the boiler.

Non-condensing models are designed for more traditional systems operating at 11°C differential temperatures and return temperature no lower than 50°C. Differential temperatures to a maximum of 15°C are acceptable.

Water Systems

Purewell VariHeat boilers are suitable for both open vented or sealed pressurised systems. Sealed systems must comply with Health and Safety Document PM5 requirements for fuel supply cut off in the event of low and high pressure conditions. To ensure compliance, consider using a proprietary pressurisation unit with correctly sized expansion vessels.

In multiple boiler installations, the flow and return headers should be connected in a “reverse return” arrangement (i.e. the water flow in each header follows the same direction) thus providing equal flow through each boiler. This also ensures that the pressure loss across any number of boilers will never be greater than the head loss across one boiler plus local pipework losses.

System Feed Water Quality

If the boiler feed water has a high degree of hardness, it is recommended that the water be treated to prevent precipitation of scale or sludge in the boiler water passageways. Details of additives can be obtained from any reliable manufacturer of water treatment products or the local water authority.

Open Vent Pipe and Cold Feed Pipe Data

Boiler	Open Vent Size	Cold Feed Size
<60kW	25mm (1 in)	19mm (¾ in)
60kW - 150kW	32mm (1¼ in)	25mm (1 in)
150kW - 300kW	38mm (1½ in)	32mm (1¼ in)
300kW - 600kW	50mm (2 in)	38mm (1½ in)

Pressure Relief Valve

Each boiler, or in the case of a modular installation, each bank of boilers, must be fitted with a pressure relief valve to BS EN ISO 4126-1, and sized as shown in BS 6644.

Hamworthy can supply Purewell VariHeat pipe kits which have isolation valves for each boiler, to enable individual boilers to be shut down from the system. The pipe kit includes a three-port valve on the flow connection for each boiler, enabling a single safety valve to be fitted to the connection on the header pipework. Safety valves are not included.

Where these pipe kits are not used, each boiler must be fitted with a safety valve in the flow pipework, positioned before any other valve in the system. BS 6644 provides comprehensive information for the selection and location of safety valves and attention is drawn to the higher capacity requirements of safety valves for pressurised hot water systems.

Delivery

Each boiler is despatched fully assembled and factory tested with the casing and control panel fitted. The boiler base has been designed to accept a pallet truck allowing easy manoeuvrability. The assembly is protected with cardboard edging and shrink wrapped for transportation.

The primary flue pipe is supplied separately for fitting on site.

All Hamworthy products are delivered to site on a tail-lift vehicle, and deliveries are closely co-ordinated with the customer, to suit the site construction programme. Standard delivery is to ground level from the tail-lift of the vehicle. To enquire about special delivery services, please contact our customer services team.

Commissioning

Hamworthy Heating strongly recommend that all boilers are commissioned by our service department. On completion, Hamworthy will issue a boiler log book which will provide details of the initial operating settings. The log book should be used to record any future maintenance and service work.

For more information on commissioning contact Hamworthy Heating Service Department: Tel 0845 450 2866.

Warranty

Products from Hamworthy carry a standard two-year warranty on parts, and where the product is commissioned by Hamworthy service engineers, then the warranty covers parts and labour. In offering flexible solutions for after sales support, Hamworthy can tailor packages to suit individual customer requirements, many of which include extended warranty benefits.

System Head

Guidance Note PM5 Health and Safety Executive

This note states that "hot water boilers should have an automatic control apparatus to cut off fuel to the burners of gas fired plant when the water at or near the boiler flow outlet rises to a pre-determined temperature. This should provide a margin of at least 17°C below the temperature of saturated steam corresponding to the pressure at the highest point of the circulation system above the boiler." To comply with this recommendation, the minimum system pressure is dependant on system design flow temperatures and in the case of modular installations, the temperature rise across each module.

Single Installations

The minimum pressure must be equal to the gauge pressure equivalent to the saturated steam temperature obtained by adding 17°C to the required boiler flow temperature. The highest point of the circulation system above the boiler should never be less than 2m (6.5ft).

■ Required flow temperature	90°C
■ Safety margin	17°C
■ Equivalent saturated steam temperature	107°C

From steam tables corresponding gauge pressure 0.3 bar – 3.0m head of water.

Modular Installations

The minimum pressure should be equal to the gauge pressure equivalent to the saturated steam temperature. This is obtained by adding 17°C to the sum of the required mixed flow temperature plus the temperature rise across the modules.

■ System Δt	11°C	20°C
■ Required mixed flow Temperature	82°C	80°C
■ Temperature rise across modules at minimum flow rate	11°C	20°C
■ Safety margin	17°C	17°C
■ Equivalent saturated steam temperature	110°C	117°C
■ From steam tables corresponding gauge pressure	0.43 bar (4.40m)	0.80 bar (8.20m)

From steam tables corresponding gauge pressure at 11°C Δt 0.43 bar, 4.40 m

From steam tables corresponding gauge pressure at 20°C Δt 0.80 bar, 8.2 m

Air Supply and Ventilation

An adequate supply of fresh air for combustion and ventilation must be provided in accordance with BS 6644.

The air supply should be free from contamination such as building dust and insulation fibres from lagging. To avoid unnecessary cleaning and servicing of the burner, we recommend that the boilers are not fired whilst building work is being undertaken.

The air supply should be achieved using:

- Natural ventilation supplying air

with a low level opening and discharge through a smaller sized high level opening.

- A fan to supply air to low level with natural discharge through a high level opening.
- A fan to supply air to low level and discharged by means of a fan at a high level.

Note: Fans must be selected such that a negative pressure is not created in the boiler house relative to outside air pressure.

The air supplied for boiler house ventilation should be such that the maximum temperatures within the boiler house are as follows:

- At floor level 25°C (or 100mm above the floor level)
- At mid level 32°C (1.5m above floor level)
- At ceiling level 40°C (or 100mm below ceiling level)

Where natural ventilation is used suitable permanent openings at low level and high level connected directly to the outside air should be provided. These openings must be fitted with grilles that cannot be blocked or flooded.

The free area of the grilles should be as follows:

Low Level (Inlet)
4cm² per kW of net heat input.

High Level (Outlet)
2cm² per kW of net heat input.

Ventilation

Where a boiler installation is to operate throughout the summer months, e.g. for domestic hot water production for more than 50% of the time, then additional ventilation allowances are required. Refer to BS6644 for more detailed information.

The Building Regulations 2000

Conservation of fuel and power 2006 edition

Approved Document AD L2A New Buildings, other than dwellings
Approved Document AD L2B Existing Buildings, other than dwellings

These new regulations came into force 6 April 2006. Compliance with the latest regulations now requires a whole building approach to reduction in carbon emissions. The 2006 edition requires the use of heat generating plant as detailed in the supporting 2nd tier guide - Non Domestic Heating, Cooling and Ventilation Compliance Guide.

Seasonal Efficiency

The efficiency data used for evaluating commercial boilers is known as the heat generator seasonal efficiency and this guide states that for new buildings and existing buildings, the minimum heat generating system seasonal efficiency is 84% gross for natural gas.

The heat generator seasonal efficiency for Purewell VariHeat boilers exceeds the minimum requirement, Individual boiler figures can be found on pages 6 & 7.

Primary Circuit Pump

Purewell VariHeat Boilers

Pumps for circulation through the boilers should be sized according to the flow rate and pressure loss requirements for a boiler, or group of boilers, and associated local pipework. For details of flow rate requirements and boiler pressure loss, please refer to data tables on pages 6 and 7.

Hamworthy Heating is the exclusive distributor of Biral pumps in the UK. With a wide range of models available, you can closely match pump performance to suit your requirements.

The high quality design with innovative features include:

- Unique Can system – no seals to leak
- Low, medium and high speed ranges
- High torque starting
- Ultra low power consumption
- Flat performance curves – less system noise
- Operating pressures up to 16 bar
- Temperatures from -20°C to 140°C
- Whisper quiet pump operation

Matched Biral Pumps for 20°C Δt Primary Circuit - Condensing Purewell VariHeat Boilers

Model	Number of Boilers			
	1	2	3	4
PV 70c	MX12-3	LX323-2	LX326 or LX402*	LX403
PV 95c	MX13-3	LX325 or LX401*	LX403	LX503
PV 110c	LX323 or LX401*	LX326 or LX402*	LX503	LX504
PV 140c	LX402	LX503	LX652	LX653
PV 180c	LX403	LX504	LX653	LX654

Matched Biral Pumps for 11°C Δt Primary Circuit - Condensing Purewell VariHeat Boilers

Model	Number of Boilers			
	1	2	3	4
PV 70c	M14-2	LX403	LX504	LX653
PV 95c	LX326 - LX402*	LX504	LX653	LX654
PV 110c	LX503	LX653 L	LX654	LX655
PV 140c	HX402-1	HX502-1	L804 or HX652*	L805 or HX802*
PV 180c	HX502-1	HX652	HX802	L1003

Matched Biral Pumps for 11°C Δt Primary Circuit - Non Condensing Purewell VariHeat Boilers

Model	Number of Boilers			
	1	2	3	4
PV 65he	LX322-2	LX326 or LX401*	LX503	LX652
PV 85he	LX323-2	LX403	LX652	LX652
PV 105he	LX403	LX504	LX653	LX654 or LX802*
PV 125he	LX503	LX653	LX654 or LX802*	LX803

Matched Biral Pumps for 15°C Δt Primary Circuit - Non Condensing Purewell VariHeat Boilers

Model	Number of Boilers			
	1	2	3	4
PV 65he	LX321-2	LX325	LX326 or LX402*	LX503 or LX652*
PV 85he	LX323-2	LX326	LX503	LX652
PV 105he	LX323-2	LX403	LX504 or LX652*	LX652
PV 125he	LX502	LX503	LX653	LX653 or LX802*

* Matched pump selection depends on installation pipe size. Contact our technical department on 01202 662379 for guidance.

Wiring Diagram

Purewell VariHeat Boilers

The following electrical connections are provided on each module:

- Supply live neutral and earth
- Supply input for boiler fault and normal run signals
- Boiler fault alarm system signal output
- Boiler normal run signal output
- 0-10v analogue control signal input
- Remote on/off control input
- Boiler shunt pump output
- Safety interlock circuit input

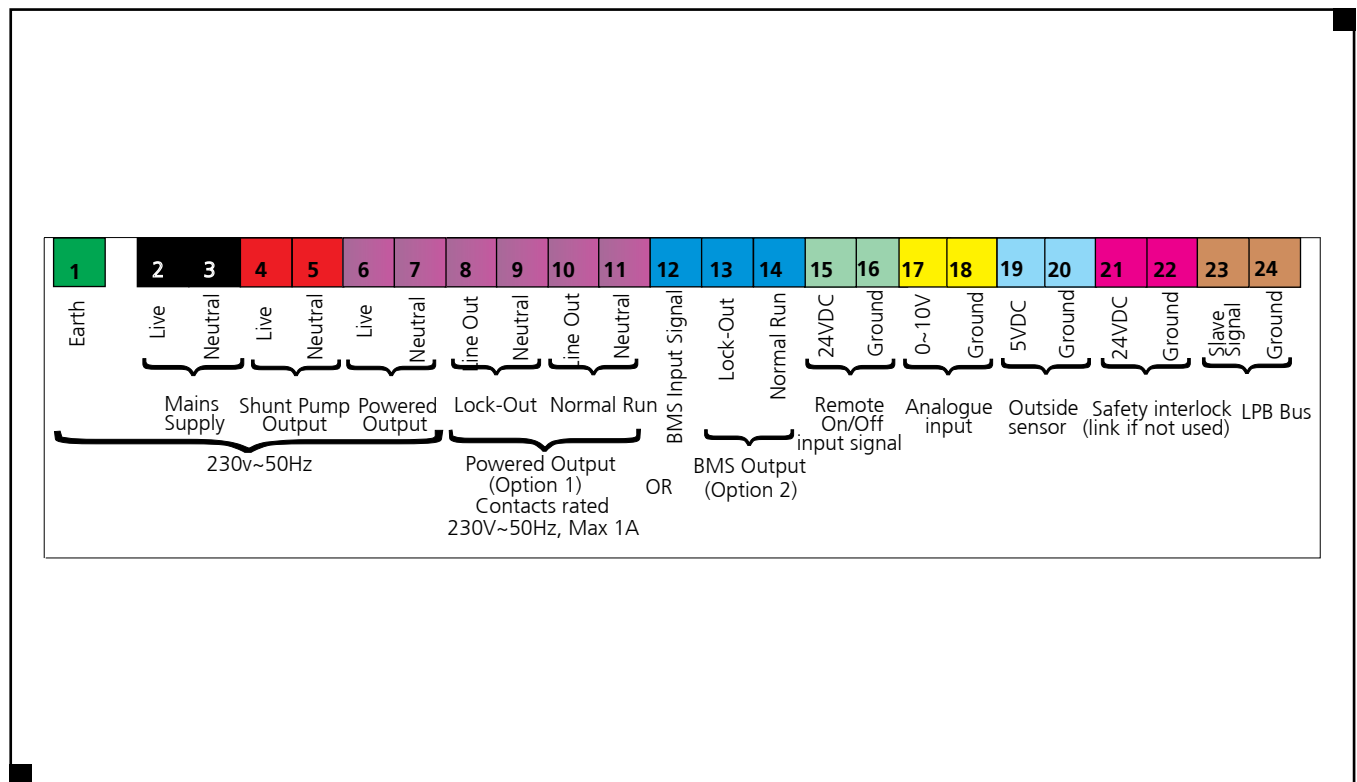

Electrical Connections

There is a gland plate fitted to the front of the boiler, at floor level, to accept cables for power supply and controls. A single terminal rail is fitted inside the front cover, and all external connections are made to this terminal rail. The plug-in terminal rail facilitates easy removal for improving access during servicing and maintenance.

Power Supply

An independent isolator and fused electrical supply is recommended for each boiler. Supply 230 volt, 50Hz, single phase. Wiring external to the boiler must be installed in accordance with IEE Regulations and any local regulations which apply. Wiring must be completed in heat resistant 3 core cable, (size 1.0 mm² c.s.a.) Fascia fuse rating is 2 amp. External fuses should be 6 amp for all single boiler sizes.

To prevent drawings excessive current (>1 amp) through the boiler control panel, it is recommended that pumps are connected via contactors.

Wiring Diagram

Cascade and Heating Zone Controls

Controls Installation

The RVA46 and RVA47 controls are designed for panel mounting. It is recommended that the controls are mounted with the fascia exposed externally for ease of use.

All electrical connections use polarised coloured screwed terminal blocks to ensure that once installed and commissioned, connections are easy to relocate in their original position, if removed.

The LPB bus communication cable between controllers and boiler can be extended to a maximum 1400 metres length. Cable should be (non interchangeable) two core twisted with 1.5mm² CSA.

Room temperature sensors, QAA10, QAA50 and QAA70, may be located up to 50 metres from their respective RVA controller. Wiring between controllers and the room sensors using 2 wire (interchangeable) cable. Max 1.5mm² CSA.

External air sensor QAC34 may be located up to maximum 120 metres from the RVA controller. Usually connected to the RVA47, wiring using 2 wire (interchangeable) cable. Max 1.5mm² CSA.

Water temperature sensors, QAZ21, may be located up to maximum 120 metres from the RVA controller. Wiring using 2 wire (interchangeable) cable. Max 1.5mm² CSA.

Pump outputs are volt free contacts rated to 2 amps 230V max. It is strongly recommended that pumps and mixing valves are connected via contactors, where higher running currents will be experienced.

Panel cut-out dimensions for RVA46 & RVA47 controllers

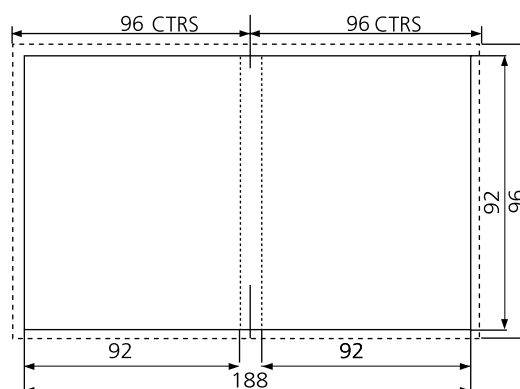

The mechanical mounting allows fitting in panel fronts that have a thickness of 2mm to 10mm.

Wiring terminal connections - RVA47 cascade controller

Low voltage terminals

6	5	4	M	2	1	M	M
H1	B3	M	B10	B9	MDA6	MBDB	

Mains voltage terminals

3	2	F	4	3	2	F	L	N
Q3	Q1	F1					L	N

- Remote enable circuit - H1/M - Volt free / 0-10 v Dc
- DHW cylinder sensor - B3/M
- Ground for sensors and remote enable circuit-M
- Cascade sensor - B10 / M
- Outside air sensor - B9 / M
- Ground for room sensor-MD
- Signal for room sensor-A6
- Ground for LPB Bus Communication-MB
- Signal for LPB Bus Communication-DB
- Live output for DHW cylinder pump max 1AMP load-Q3
- Live input for DHW cylinder pump 230v 50Hz
- Live supply 230v 50Hz 5AMP
- Neutral

Wiring terminal connections - RVA46 zone controller

Low voltage terminals

6	5	4	M	2	1	M	M
H1	M	B1	B9	MDA6	MBDB		

Mains voltage terminals

3	2	F	4	3	2	F	L	N	
Y2	Y1	F2				Q2	F6	L	N

- Remote enable circuit - H1/M - Volt free / 0-10 v Dc
- Ground for sensors and remote enable circuit-M
- Flow sensor for mixing valve - B1/M
- Outside air sensor - B9/M
- Ground for room sensor-MD
- Signal for room sensor-A6
- Ground for LPB bus communication - MB
- Signal for LPB bus communication - DB
- Close output for mixing valve max 1AMP load-Y2
- Open output for mixing valve max 1AMP load-Y1
- Live input for mixing valve 230v 50Hz
- Live output for heating zone pump max 1AMP load-Q2
- Live input for heating zone pump 230v 50Hz
- Live supply 230v 50Hz 5AMP
- Neutral

Flue System

Purewell VariHeat Boilers

Purewell VariHeat boilers have a pressurised flue outlet, enabling a flue installation to be designed using smaller diameter components.

The following points should be noted:

- A suction condition within the flue is not required, so it may be possible to achieve a lower chimney terminal height, however all installations must still comply with the requirements of the Clean Air Act 1956 Memorandum.
- The flue system must be capable of handling saturated flue gases in a positive pressure system, particularly for the condensing model, however, there will also be condensate generated from the non condensing models during certain operating conditions.
- The boilers may be flued individually, using Hamworthy fully welded Masterflue components. *Details of flue sizes and length of flue runs are shown on page 27.*
- Multiple boilers may be installed using a common flue header. Please consult with our flue technical team for further advice.
- The flue components should be fully welded and CE marked for positive pressure application.
- Draught conditions generated from vertical risers should not exceed 10 Pa. Where draught conditions are likely to exceed 10 Pa, it is recommended that a draught stabiliser is fitted.
- Where multiple boilers are used, a draught stabiliser located in the end of the header is preferred to individual draught stabilisers located on each boiler outlet.
Draught generated:
at 140°C, 4 Pa/m
at 80°C, 2 Pa/m
at 40°C, 0 Pa/m
- The flue system must be self supporting and facilitate access for cleaning and maintenance near the boiler connection.
- When designing the flue system, care must be taken to ensure that any condensate that may form within the system can be drained safely to a suitable waste point, and that the flue and drain materials are resistant to the corrosive effect of condensate.
- Purewell VariHeat boilers are suitable for installation in a balanced compartment in accordance with the requirements of BS 6644.

Flues from Hamworthy

The Masterflue MF system from Hamworthy is a modular, twin wall, insulated, fully welded flue solution, optimised for high efficiency and condensing boiler applications.

Leak-Free

- Unique factory fitted tri-lip silicone gasket as standard ensuring a leak proof, high temperature seal, impervious to water and vapour.
- All components fully welded and pressure tight, including traditionally troublesome elbows.

Corrosion-Free

- Premium grade stainless steel construction for inner and outer walls.
- 87 degree elbows and tees to ensure condensate drains effectively.

Worry-Free

- Fast, push-fit assembly with no need for additional sealants.
- Precision finished, reliable components for high quality installation.
- Range of 'Tru-Align' adjustable wall brackets for simplifying alignment, achieving a faster installation and neater finish.
- Continuous insulation from base to stub.
- Fire resistant - 4 hour fire rated.
- Stress-free thermal expansion.
- CE mark accredited to meet 2005 legislation.

Hamworthy also have the Masterflue ME flue component range which is a single wall construction, fully welded flue system. The Masterflue ME range is totally compatible and interchangeable with the Masterflue MF twin wall range.

Design & Install or Supply Only

Hamworthy's extensive knowledge of combustion systems, and the flue requirements for each boiler, makes a boiler and flue package the perfect solution for every project.

Offering a comprehensive range of flue and chimney equipment for natural draught, fan assisted and fan dilution applications, Hamworthy works in partnership with Midtherm Engineering to provide a comprehensive flue design and installation package.

Alternatively, Hamworthy can provide components on a supply only basis for the contractor to install. Speak with Hamworthy Midtherm about your flue requirements and get peace of mind on your next project - guaranteed.

Tel: 0845 450 2867

Email: hamworthy@midtherm.co.uk

Flue Guide

Purewell VariHeat Boilers

Flue System for Individually Flued Single Boilers Only

The table below provides a guide to the maximum flue length allowed for each boiler using 100 mm diameter components on non condensing boilers.

Purewell VariHeat High Efficiency Non Condensing Boilers				
Boiler Model	Flue Diameter (mm)	Maximum Flue Length (m)	Equivalent Length (m)	
			90° Elbow	45° Elbow
PV 65he	100	19	1.5	1.3
PV 85he	100	12	1.5	1.3
PV 105he	100	8	1.5	1.3
PV 125he	100	4	1.5	1.3

The table below provides a guide to the maximum flue length allowed for each boiler using 150 mm diameter components, connected to the boiler primary flue which is 100 mm diameter, on non condensing boilers

Purewell VariHeat High Efficiency Non Condensing Boilers				
Boiler Model	Flue Diameter (mm)	Maximum Flue Length (m)	Equivalent Length (m)	
			90° Elbow	45° Elbow
PV 65he	150	149	2.2	2.0
PV 85he	150	88	2.2	2.0
PV 105he	150	69	2.3	2.0
PV 125he	150	47	2.3	2.0

The table below provides a guide to the maximum flue length allowed for each boiler using 150 mm diameter components on condensing boilers.

Purewell VariHeat High Efficiency Condensing Boilers				
Boiler Model	Flue Diameter (mm)	Maximum Flue Length (m)	Equivalent Length (m)	
			90° Elbow	45° Elbow
PV 70c	150	131	2.1	1.6
PV 95c	150	114	2.2	1.7
PV 110c	150	114	2.2	1.7
PV 140c	150	79	2.3	1.8
PV 180c	150	57	2.3	1.8

NOTES

1. The figures shown in these tables are calculated for Hamworthy Masterflue MF components. As the flue coupled to these boilers will be pressurised and the flue gases wet, leading to running condensation within the flue, it is important that the flue components used are fully sealed and resistant to the aggression of condensate. Masterflue MF components are manufactured from acid resistant stainless steel and incorporate a tri-lip seal at the joints to provide leak free performance.
2. 45° And 90° bends are based on Hamworthy Masterflue MF slow radius components. Alternative bends and components will have differing performance characteristics leading to a final performance that does not match the details in the chart.
3. If the flue system intended is not covered by the details in the charts then contact Hamworthy Heating for advice. Using different sizes and diameters will effect the equivalent length of flue that may be used.

Open Flue

Purewell VariHeat boilers are designed for Type B23 open flue systems.

Type B - An appliance intended to be connected to a flue that evacuates the products of combustion to the outside of the room containing the appliance. The combustion air is drawn directly from the room.

Type B2 - A type B appliance without a draught diverter

Type B23 A type B2 appliance incorporating a fan upstream of the combustion chamber/heat exchanger.

For details of the full range of classifications refer to BSI publication PD CR 1749:2001.

Equivalent Length Components

For single, or individually flued multiple boilers, it is possible to select components from the Hamworthy Masterflue MF range of components, and design a flue system that has an overall length within the specified limits.

The maximum flue length is the sum of all the vertical and horizontal sections (A + B + C) plus the equivalent lengths of all the 90 degree and 45 degree elbows.

The tables opposite provide details of the flue system maximum lengths, and the equivalent lengths for the elbows.

Flue System for Multiple Boilers

Multiple boilers may be installed using a common flue header. For multiple boiler flue applications or where an existing flue system is to be used, please consult with our flue technical team for further advice.

Tel: 0845 450 2867

Email: hamworthy@midtherm.co.uk



Customer Service Centre

Hamworthy Heating Limited
Fleets Corner, Poole,
Dorset BH17 0HH

Telephone: **0845 450 2865**
Email: **sales@hamworthy-heating.com**
Web: **www.hamworthy-heating.com**

Hamworthy reserves the right to make changes and improvements which may necessitate alteration to the specification without prior notice.

500002373 