



# Hamworthy Merley

Boiler Sequence Controller



Heating *at work.*

# Merley

## Boiler Sequence Controller

Good control of primary heating and hot water plant and distribution systems is a vital part in achieving low energy consumption and reducing carbon emissions. The principle requirement is to provide heat and hot water only when and where it is needed and at the right temperature, whilst minimising boiler cycling.

The use of multiple boilers is a well established and highly effective approach to heating system design in commercial buildings, and achieving good control of multiple boiler installations is essential to meet the demand for high system efficiencies, and to exceed the Building Regulations recommended minimum standard for controls.

The Hamworthy Merley boiler sequence controller uses the ultra reliable Siemens controls platform to provide efficient boiler cascade control for up to 16 modules, based on time and temperature requirements.

Supplied fully assembled in a steel enclosure for wall mounting, the Merley can be used as a standalone device which will manage the boilers and associated heating and hot water circuits, providing an extensive range of features to maximise system performance whilst at the same time being easy to use.

Alternatively, there is an option to supply the Merley as loose items in a kit for installing in a central plant control panel.

The Merley can be integrated with a building management system (BMS) to operate as the boiler sequence controller, responding to input from the BMS.

A wide choice of options ensure the Merley can deliver controls solutions for a wide range of buildings and heating applications.

- **Energy saving functionality**
- **Reduces carbon emissions**
- **Even usage of boilers**
- **Intelligent self learning control**
- **Wireless sensors easy to install**
- **Versatile control strategies**
- **Heating zone & DHW management**

BENEFITS

**Achieving good control of multiple boiler installations is essential to meet the demand for high system efficiencies, and to exceed the Building Regulations recommended minimum standards.**

## Options

- **Loose kit controller**
- **External air sensor**
- **Choice of room sensors**
- **Hard wired controls**
- **Wireless controls**
- **Domestic hot water sensor**
- **Strap on flow temperature sensor**



*Merley wall mounted boiler sequence controller*

# Specification

## Merley

Merley is the latest generation boiler sequence controller for multiple boiler installations. Using the Siemens controls platform, Hamworthy boilers can be controlled to share the load between boiler modules to maximise efficiency and system performance.

Adaptable control capability allows integration of the Merley sequence controller with most commercial heating system designs, with the ability to operate as a standalone controller operating from its own internal programs or as an integrated part of a more dynamic building management system.

As a standalone device with autonomous control of the boilers, the controller can be extended to sequence control the boilers and also to manage a complete heating circuit as well as a domestic hot water (DHW) cylinder.

A range of room and external air temperature sensors, including wireless options, ensures comfort levels within the building are maintained.

When integrated with a building management system (BMS), the Merley operates only as a boiler sequence controller, receiving the required operating temperature from the building management system via a 0 to 10 volt analog signal.



*Merley user digital interface*

Each sequence control system is supplied with a smart digital interface display allowing the user to monitor the current operating status of the boilers, and also the building where the Merley is used to control a heating zone and hot water cylinder.

## Heating & Domestic Hot Water Control

Control Features:

- Provides sequence control from a choice of inputs:
  - External enable signals
  - 0-10v analogue heat demand signal
  - Built-in time clock setting
- Up to 16 boiler modules may be sequenced
- Control of a single heating circuit with heating circuit pump and three port mixing valve
- Control of a single DHW calorifier with primary loading pump
- Choice of sequence strategies
- Lead boiler rotation
- Fixed lead boiler priority
- Individual 7 day time clock settings for boilers, heating circuit and DHW calorifier with automatic summer/winter clock adjustment
- 3 programmable periods per day per circuit
- Optimised start and stop based on external and room air temperatures
- Holiday period. Frost protection remains active
- Over ride facility
- Constant or variable temperature flow
- Compensated flow temperature based on external and room air temperatures
- Automatic adaption of heating curve (self learning)
- Frost protection based on boiler water temperature, external air temperature and DHW water temperature
- Building frost protection based on room air temperature
- Summer shutdown based on outside air temperature
- Reduced temperature/night set back for non occupancy hours
- Pump kick for pumps controlled from boiler
- Hard wired or wireless external air sensor communication
- DHW Legionella protection program
- DHW/Heating priority settings
- DHW Temperature control using calorifier control thermostat (manufacturer supplied) or optional water temperature sensor

# Specification

## Merley

The Merley boiler sequence controller can be supplied within a dedicated housing for wall mounting or as a loose kit for integrating within a plant room control panel.

### Wall Mounted Controller

Merley sequence controllers are available factory assembled within a robust steel enclosure suitable for wall mounting, with the digital interface display pre-mounted to the housing door.

The sequence controller is mounted to a DIN rail attached to the panel back plate assembly, with electrical trunking to simplify routing for site cables to the appropriate wiring terminations.

A cable gland plate is located on the underside of the control panel with 6 loose cable glands supplied for fitting on site.

### Loose Kit Controller

For installations where the sequence controller will be integrated within an existing or new plant room control panel, the Merley sequence controller can be supplied in loose kit form.

A suitable space must be allocated within the plant room control panel for mounting the sequence controller to the back plate and for mounting the digital display to the control panel door.



*Merley loose sequence controller kit*

### Boiler Sequence Control

Merley is primarily a boiler sequence controller for optimising the number of boilers firing at any one time to suit the system and building heat requirements.

Additionally the Merley boiler sequence controller can manage the operation and comfort requirements for a single heating zone as well as the production of hot water via a single DHW calorifier.

### Heating Zone Control

In addition to the sequence control functions, a single heating zone can be connected into the system to provide a comprehensive building control solution.

A dedicated program with 7 day time clock function provides independent control for the heating zone. Use of a room temperature sensor also provides optimised start/stop functionality.

With a variable temperature heating circuit, using a room sensor can provide greater comfort control where flow temperature within the circuit is adjusted according to both external air temperature and internal room temperature conditions.

The heating zone is able to operate completely independently from the hot water circuit.

The sequence controller responds to heat demand from the zone and controls flow temperature from the boilers to satisfy requirements. Where a hot water circuit is present which may be operating with a higher temperature requirement, conditions within the heating zone are managed using a mixing valve.

Pump and mixing valve outputs are provided, allowing for constant temperature and variable temperature system design.

### Domestic Hot Water Control

Production of hot water may be controlled via the sequence controller using a single hot water cylinder.

The sequence controller can be configured to measure hot water temperature within the cylinder either using a mechanical thermostat (normally supplied by the cylinder manufacturer) or using the optional domestic hot water temperature sensor.

The hot water circuit is provided with its own dedicated time program, and also has a separate night set back feature, frost protection and an anti legionella function.

The primary circuit to the calorifier is controlled using the domestic hot water pump output, which is energised only when a hot water demand is present. This pump should be connected to the controller via a relay contactor.

Priority settings allow DHW priority over the heating circuit, or shared priority where heating and hot water production operate in tandem.

### Immersion Heater Output

An electric immersion heater may be controlled from the boiler sequence controller via an electrical contactor, and can be set to operate under these conditions:

- Whenever all the boilers are at fault condition, e.g. total gas supply failure
- Whenever all heating circuits have turned off due to summer operation. Boilers resume cylinder heating when providing heat once again to the heating circuits

**Note:** Any immersion heater circuit must include a high limit thermostat in the controls wiring to ensure the power supply is safely interrupted in the event of an over temperature condition

## Boiler Sequence Control Strategies

The Merley sequence controller can be configured to sequence boilers in traditional cascade mode or in unison mode.

### Cascade Control

Steps a boiler module on at its lowest rate and then modulates it to its maximum rate, before switching on the next boiler module to match the system load. Maintains the lowest number of boiler modules in operation for a given heat load.

This control strategy is particularly suited to non-condensing boilers operating in constant temperature systems where there is no great efficiency advantage to be gained from operating boilers at part load.

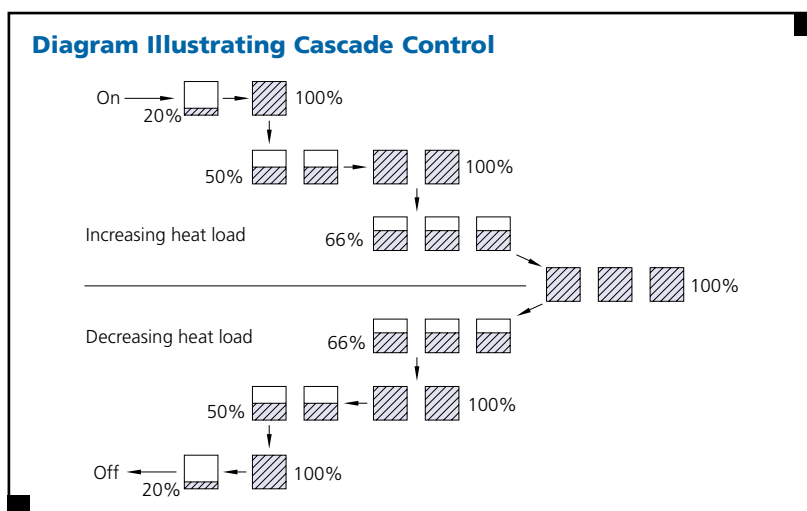

### Unison Control

Steps each boiler module on in turn at its lowest rate, and then modulates all boiler modules simultaneously to higher rates to match the system load. This method of sequencing can offer higher operating efficiencies, taking advantage of the higher part load efficiencies available at low firing rates.

This control strategy is particularly suited to condensing boilers operating in variable temperature systems where low water temperatures and part load boiler operation allows optimum boiler operating efficiency to be achieved.

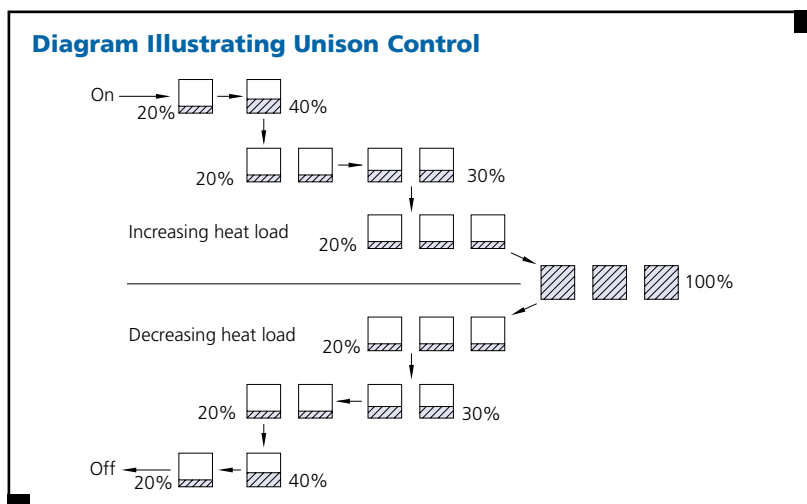

## Boiler Communications

Up to 16 Hamworthy boiler modules can be controlled using the Merley sequence controller and communication between each boiler and the sequence controller is via an LPB bus.

Each boiler module is equipped with a dedicated controller managing its safety functions and combustion system.

Included with the supply of the Merley sequence controller are:

- Two clip in LPB bus communication modules\*
- One insertion type flow temperature sensor with pocket



*Boiler controller with clip in LPB BUS communications module*

**\*Note:** When controlling more than two boiler modules, additional clip-in LPB bus communication modules must be ordered separately.

(I.e. A four boiler installation with a cascade control kit requires two additional LPB bus communication clip-in modules)

### External Air Sensor

An external air temperature sensor should be used with all sequence controller installations to enable functionality including:

- weather compensation
- optimised start and stop
- frost protection
- summer shutdown

The external air sensor must be located on an external wall with northerly aspect away from any heat sources.

Hard wired and wireless versions of the external air sensor are available. See *wireless sensors and communication*, page 9.

# Specification

Merley

## Flow Temperature Set Point

Flow temperature is set according to the operating parameters for the heating system. This may be constant temperature suited to DHW production and air handling units, or variable temperature more suited to radiant panel and underfloor heating systems.

In variable temperature (weather compensated) systems the rate of heat loss from the building is accounted for by raising or lowering the flow temperature according to external air temperature. The heating curve corresponding to the required flow temperature is fully adjustable with curve settings from 0.25 to 4.0.

When there is more than one temperature demand, e.g. when there is a hot water cylinder as well as a heating circuit, the sequence controller will always initiate heat generation to the highest heat demand. See *heating zone control*, page 4.

## Flow Temperature Control

The sequence controller compares actual flow temperature with current flow temperature set point to calculate how many boilers are required to fire, and the modulation rate for each boiler, to achieve and maintain the desired flow temperature.

The number of boilers required to fire is chosen according to the selected sequence control strategy.

## Flow Temperature Sensor

A flow temperature sensor must be used with all sequence controller installations and located in the common flow pipework after the boilers and before any low loss header and secondary circuit connections.

An insertion type temperature sensor is supplied with each sequence control kit complete with pocket. Hamworthy strongly recommend using the insertion type flow temperature sensor for accurate flow temperature measurement.

Where absolutely essential, a surface mounted flow temperature sensor can be supplied as an option.

## Using BMS 0-10 Volt Signals

The sequence controller can be configured to accept a BMS analog input to initiate heat generation.

**Note:** When using a BMS to initiate cascade control via a 0-10 volt analog signal, the internal time clock and remote enable circuit functions are disabled.

Input signals to the sequence controller must be temperature configured. The input signal is translated to a temperature set point for the flow temperature, and translation is according to a linear graph from 5°C to an upper limit set during commissioning.

10 Volts corresponds with the upper limit with a maximum 90°C setting.

**0 – 10 Volt Analog Temperature Input Chart**

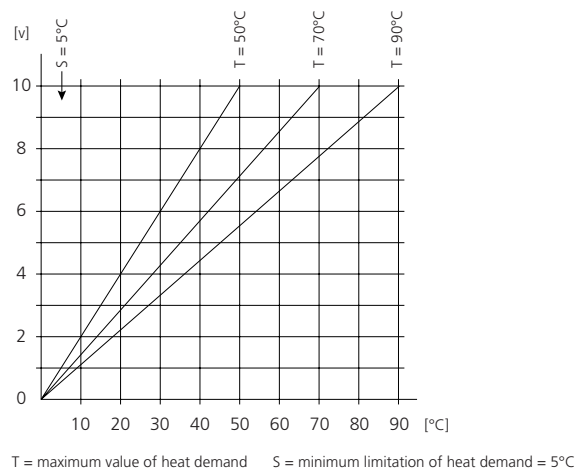

When there is no analog input, the boilers will not fire unless the frost protection function of the boiler is activated. It is recommended that boiler primary circulation pumps are always controlled from the boilers to prevent boiler operation without circulation. Please refer to the section on *pump control*, page 8.

Whilst operating with an analog input signal, the cascade controller will provide lead boiler rotation, programmable for number of hours run.

**Weather Compensated Flow Temperature Chart**

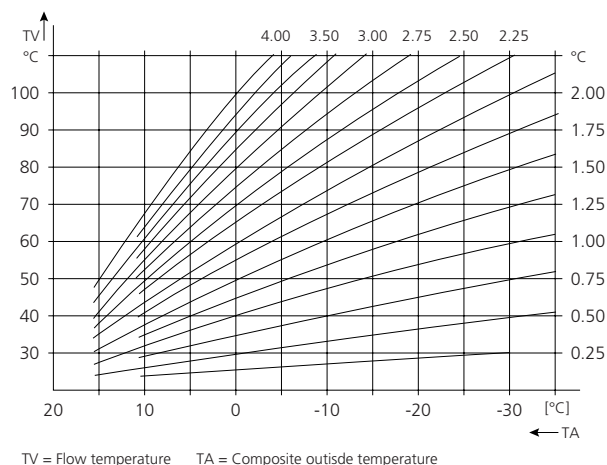

### Heating Curve Displacement

To further enhance comfort levels within the building, when used in conjunction with a room temperature sensor, the cascade flow temperature set point will be adjusted, dependent on actual room temperature. I.e. if the room temperature is high then the control will further reduce the flow temperature automatically.

Further enhancements for comfort can be made using the offset adjustment for the heating curve, programmable to reset the curve parallel to the original +/- 4.5°C

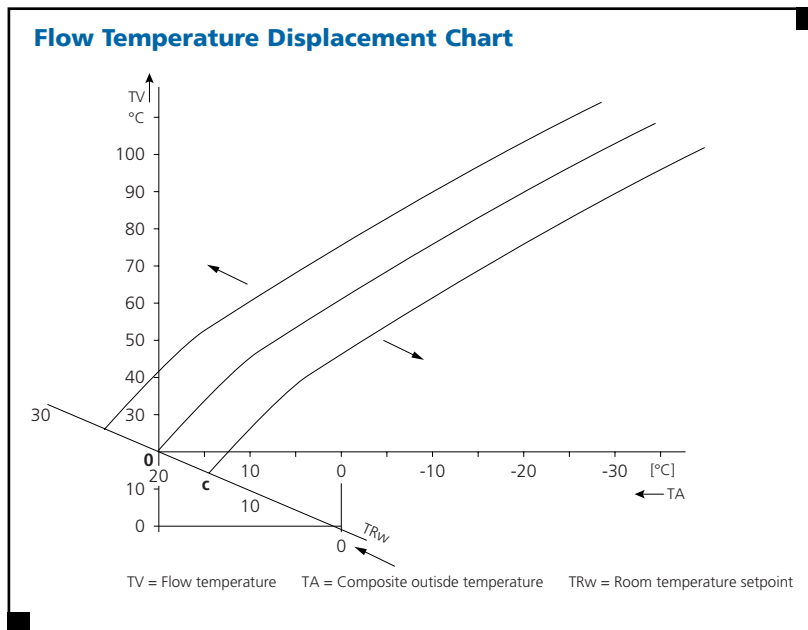

### Frost Protection

Individual frost protection settings are provided for the building, domestic hot water cylinder and plant.

The building is protected according to room temperature, whereby during non occupancy periods room temperature will be maintained to the frost protection setting.

Stored hot water temperature forms the basis of protection for the hot water cylinder whereby the hot water cylinder temperature will be maintained to the frost protection setting.

Plant is protected based on external air temperature whereby circulating pumps are started to make use of residual heat from the building to protect plant from freezing, even if there is no request for heat.

Boilers are additionally provided with their own frost protection function initiating burner operation when water temperature within the boiler drops below 5°C. Where boilers are not equipped with integral pumps suitable provision must be made to start primary circuit pumps to ensure boilers do not fire without circulation.

External Air Temperature	Pump Operation
-4°C	Continuously on
-5°C - +1.5°C	Cycles for 10 minutes every 6 hours
Above 1.5°C	Continuously off

Please refer to the section on pump control, page 8.

### Time Control

A 7 day time clock with 3 adjustable time periods per day is a standard feature of the sequence controller.

### Optimised Start And Stop

The optimiser function adjusts the heating start and stop times in relation to the difference between the actual room temperature and the desired room temperature, either delaying or advancing the start and stop times to achieve or maintain the desired room temperature between the pre-set times.

The optimiser uses a combination of the actual room temperature and external air temperature to calculate the exact time at which the heating will be started or stopped to ensure comfort levels at the correct times. This way, heat loss rate from the building is accounted for, allowing the sequence controller to further fine tune start and stop times.

A self-learning function monitors discrepancies in room temperatures at the pre-defined times allowing the optimiser to fine tune to the building thermal performance.

### Manual Over-Ride

Continuous on or off operation can be set during which the time program is over-ridden until the over-ride function is manually de-activated. Frost protection and summer shutdown controls remain active.

### Remote Enable

The Merley sequence controller can be programmed to receive an enable signal from an external control system. Whilst the in-built time clock and optimiser are over-ridden, frost protection and summer shutdown remain active.

### Summer Shutdown

Whenever the external air temperature exceeds the adjustable programmed setting the heating is turned off.

# Specification

Merley

## Boiler Primary Circuit Design

It is important to ensure adequate water flow through boilers whenever it is possible that the boiler could fire. Boilers have different requirements to satisfy the need for sufficient flow, some having integral pumps matched to the flow and resistance characteristics of the boiler and others requiring a dedicated external pump in a primary circuit.

Whichever arrangement is required for the chosen boiler, it is essential to consider the pump requirements for the boilers being used when designing the controls for the primary circuit.

## Boilers with Integral Pumps

Hamworthy Fleet boilers are supplied complete with an integral pump and do not require a dedicated primary circuit pump, simplifying the controls requirements.

When the sequence controller enables a boiler, the integral pump is automatically started via the boilers in-built control system, ensuring adequate circulation. Once the boiler ceases firing, pump operation is maintained for a short period to dissipate heat from the heat exchanger, ensuring satisfactory boiler shut down.

## Boilers Requiring External Pumps

Hamworthy Wessex ModuMax, Purewell VariHeat and Sherborne SE boilers must be provided with a dedicated primary circuit pump.

In these installations it is recommended that the primary circuit pump is started via the boiler's built-in control system. Each boiler control has a shunt pump output that should be connected to an individual relay/contactor in the primary pump power supply circuit. The primary pump power supply circuit should be configured to ensure the primary pump starts whenever an individual relay, or multiple relays are energised via the boiler shunt pump circuits.

By energising the primary circuit pump via the boilers, the boilers are prevented from firing without circulation, especially in boiler frost protection mode when a heating cycle is initiated should the water temperature within the boiler drop below 5°C.

If control of the primary pump is required from an alternative source, such as a BMS system, then the frost protection set point for starting the primary pump should be higher than 5°C water temperature. This will ensure that the primary pump will have started before the boilers can operate under the influence of their integral frost protection, which is set at 5°C water temperature. Boiler pump outputs also provide an over run facility ensuring any attached pumps will dissipate residual heat once the boiler has finished firing.

**Note:** Whichever primary circuit design is adopted it is essential to allow provision in the pipework for fitting the flow temperature sensor.

## Recommended Primary Pump Wiring (Boilers requiring external pumps)

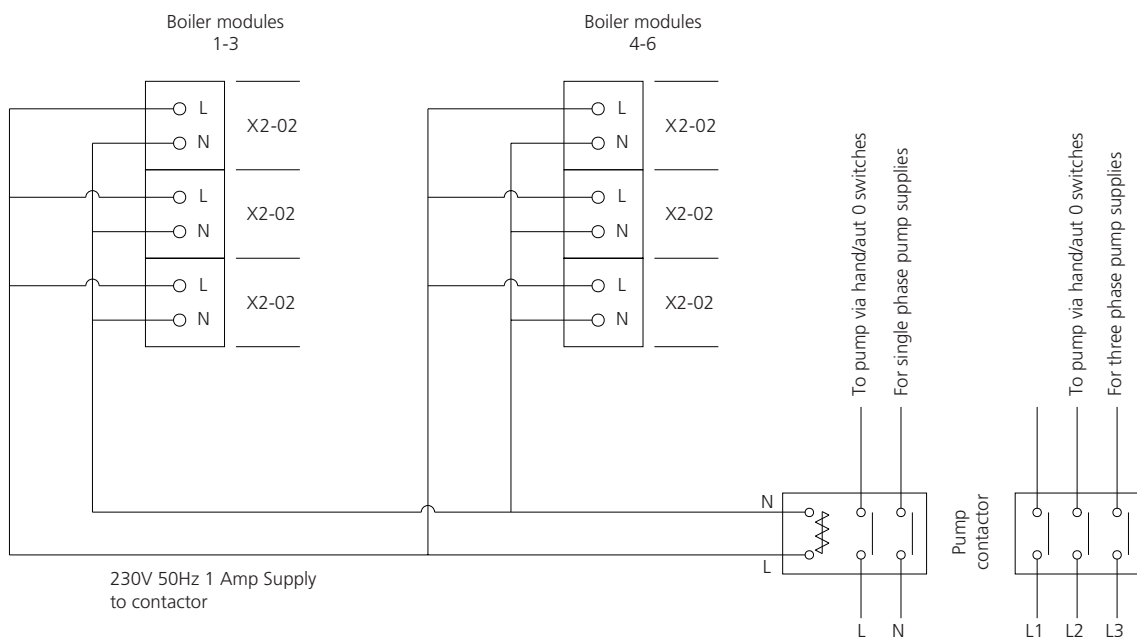

### Wireless Sensors and Communication

The Merley sequence controller is available with the option of wireless connectivity for the external air temperature sensor and the programmable room sensor. Data transmission from the sensors to the sequence controller requires connection of an optional radio module to the sequence controller. This module must not be installed inside any metal enclosure and is supplied with a 1.5 metre long dedicated cable for making the connection.

All wireless components should be located such that transmission will be as interference free as possible. The following minimum precautions are recommended:

- Sensors and radio modules should not be located in the vicinity of electrical cables, strong magnetic fields, PC equipment etc.
- Sensors should not be located near to large metal structures or construction elements with fine metal meshes such as special glass or concrete.

In normal circumstances radio transmission distance can be up to 30 metres. Where longer distances are required, or transmission within the building is impeded, radio repeater modules are available. A repeater module should be installed at least every 30 metres.

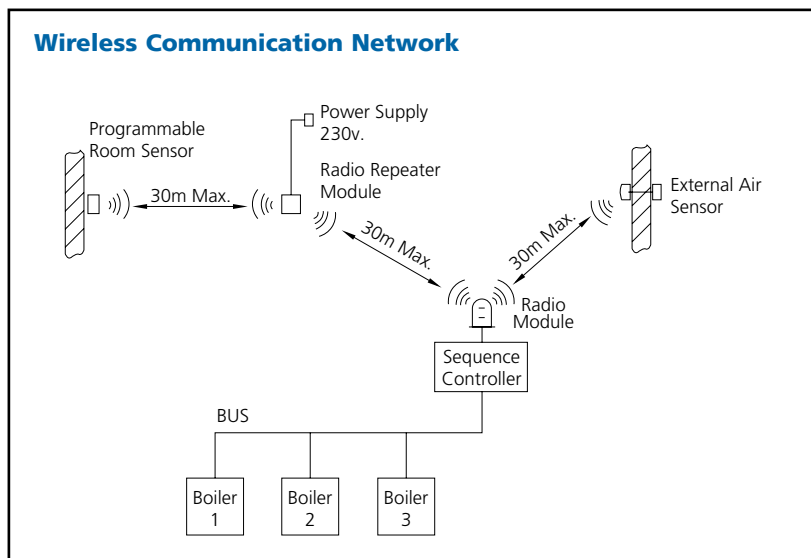

The repeater module requires a dedicated power supply and is supplied with a plug in transformer 230v – 7.5v with 3 metre cable to supply power to the repeater. A switched mains socket outlet is required within 3 metres of every repeater.

The wireless external air sensor is supplied with a repeater module that must be located on an internal wall of the building close to the external location of the sensor providing ease of access for changing the battery power supply (2 x AAA). The transmitter must be wired to the external sensor using a 2 core cable.

The wireless programmable room sensor also uses battery power (3 x AA).

### Room Sensor Location

The room sensor location should be chosen to allow accurate temperature measurement, away from direct sunlight and other sources of heat or refrigeration, approximately 1.5 metres above floor level.

### Offset Adjustable Room Sensor

For installations where limited control is required by the building occupants, the QAA55 offset adjustable room sensor may be used. This permits adjustment +/- 3°C from the programmed room temperature set point and communicates room temperature to the sequence controller.

This sensor is only available as a hard wired item.

Features:

- Setting the operating mode between automatic operation, continuous operation comfort or night setback temperature, off with frost protection active
- Setting a temporary off condition during an un-programmed non occupancy period that will reset automatically according to following program settings
- Programmable lock to prevent tampering

### Programmable Room Sensor

The programmable room temperature sensor communicates with the sequence controller and allows the user full adjustment of the room temperature, time clock, holiday periods and frost protection settings. The unit also displays fault codes from the boiler plant. Hard wired and wireless versions of the programmable room sensor are available.

Features:

- 3 programmable periods per day
- Reduced temperature/night set back for non occupancy hours
- Holiday period. Frost protection remains active
- Programme lock to prevent tampering
- Indication of operating parameters and boiler fault condition
- 7 day time clock with automatic summer winter clock adjustment



Offset room sensor (left), and programmable room sensor.

# Dimensional Details

## Merley Boiler Sequence Controller

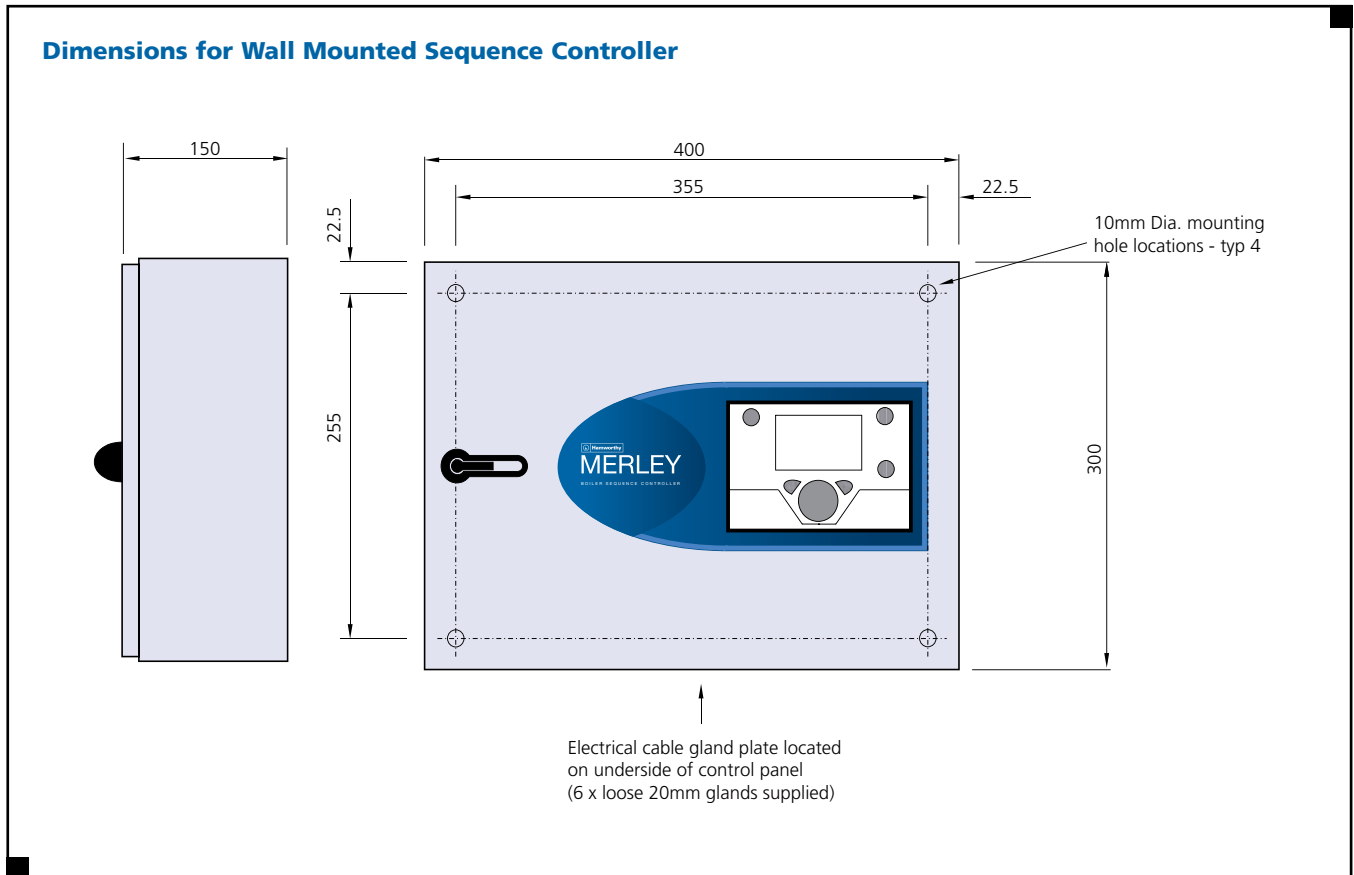

### Wall Mounted Sequence Controller

The wall mounted version of the sequence controller is supplied factory assembled within a steel enclosure panel with hinged door. The fascia display unit is mounted and connected to the sequence controller via the ribbon cable. The wall mounted unit includes:

- Steel wall enclosure with hinged door
- Factory mounted sequence controller to DIN rail
- Electrical trunking for routing wiring
- Immersion flow temperature sensor and ½" pocket
- Gland plate with 6 loose 20mm cable glands

Electrical trunking is supplied within the enclosure for routing of site cable to the electrical terminations of the sequence controller. No internal wiring is supplied.

**Note:** With both the wall mounted sequence controller kit and the loose sequence controller kit it is important to specify an external air sensor. This sensor is available in hard wired and wireless versions. When selecting the wireless version, a radio module must also be specified and possibly additional radio repeater modules. *For more details regarding wireless connection please see page 9*

### Loose Sequence Controller Kit

The loose version of the sequence controller is supplied in kit form for fitting within a control panel, either new or existing within the plant room. The kit includes:

- Sequence controller suitable for DIN rail mounting
- Digital display unit requiring provision of suitable cut-out in control panel door
- 1 metre ribbon cable for connecting digital display unit to sequence controller
- Immersion flow temperature sensor and ½" pocket

**Note:** Sufficient space must be allocated within the site control panel for fitting sequence controller to the back plate as well as for mounting the digital interface panel to the door. The digital interface display is provided with a 1 metre cable for connecting to the sequence controller.

# Dimensional Details

Merley Loose Kit

## Dimensions for Loose Sequence Controller

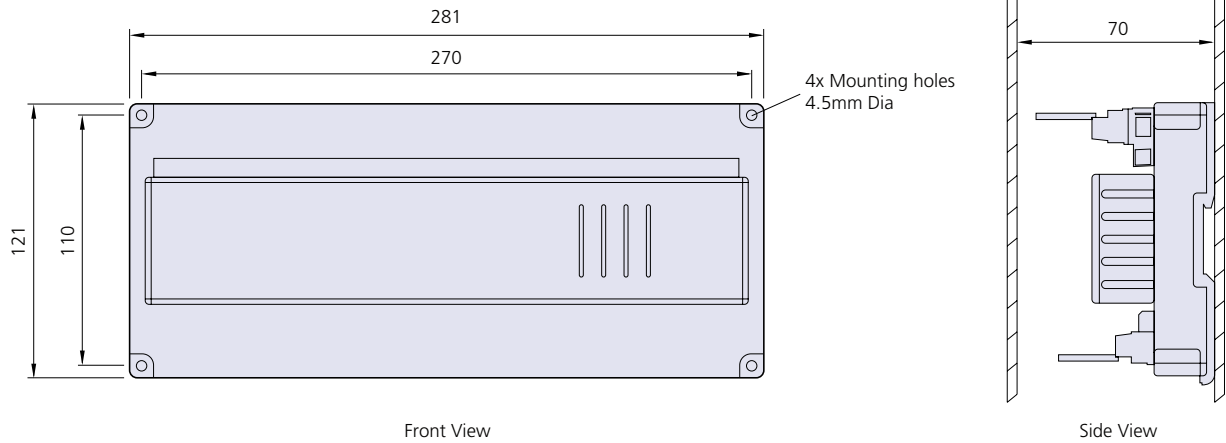

## Dimensions for Digital Display Unit

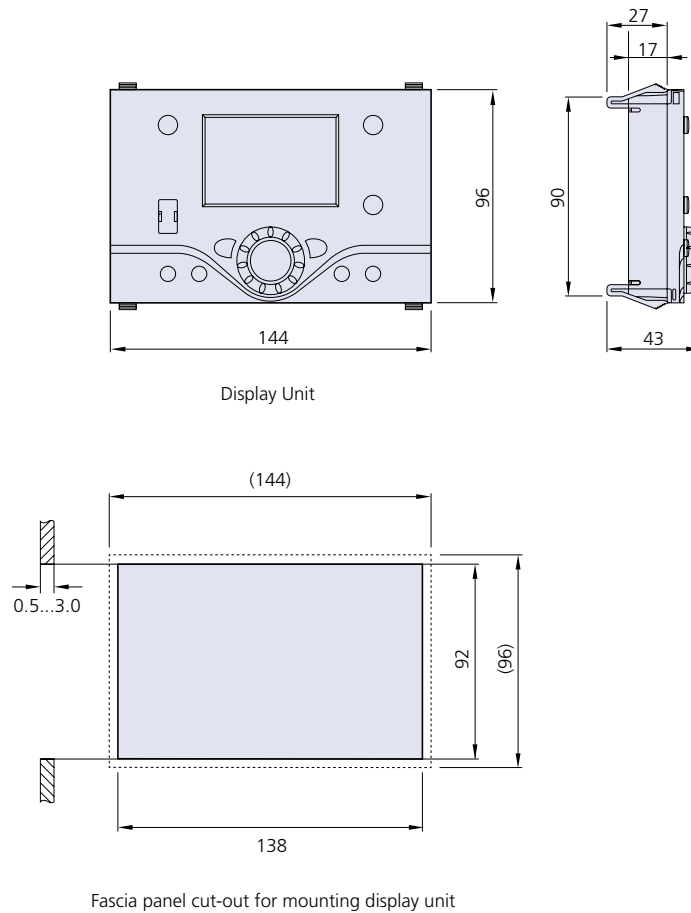

# Controls Scheme 1

Sequence Control Scheme, Boilers with Integral Pump –  
Hamworthy Fleet Boilers

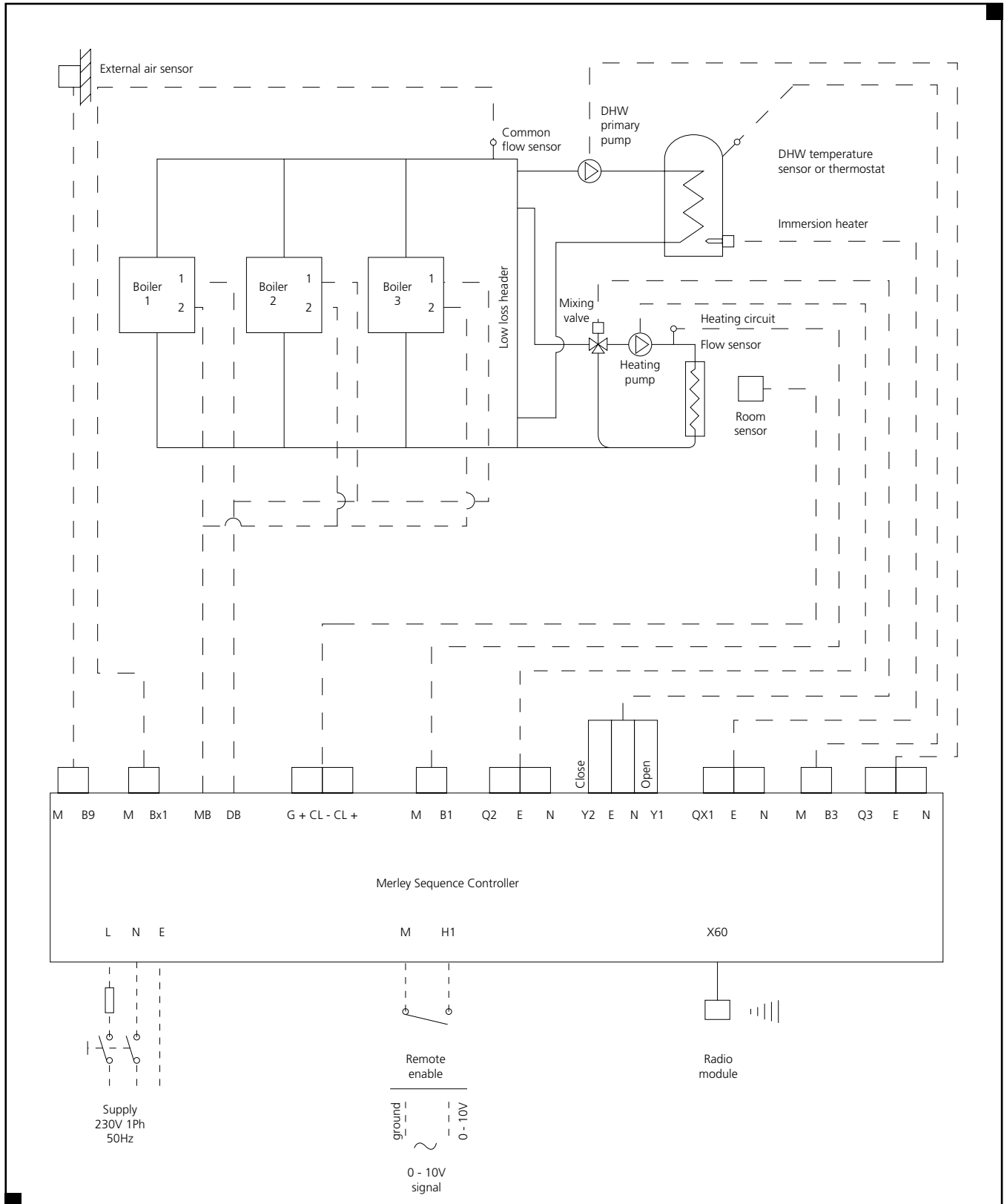

# Controls Scheme 2

Sequence Control Scheme, Boilers without Integral Pumps –  
Hamworthy Wessex ModuMax, Purewell VariHeat & Sherborne SE Boilers

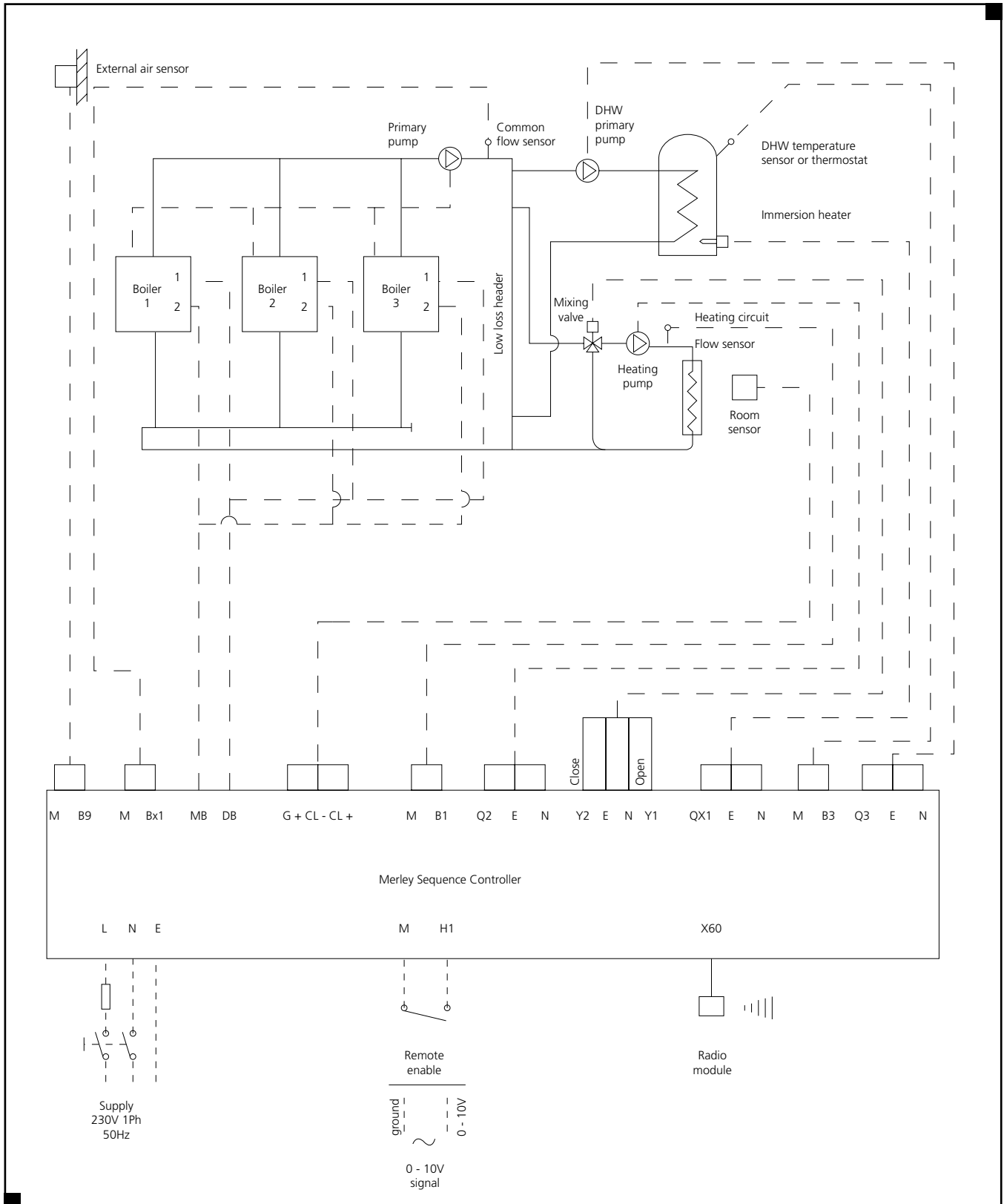

# Wiring Diagram

## Merley Boiler Sequence Controller

### Terminal Layout Diagram

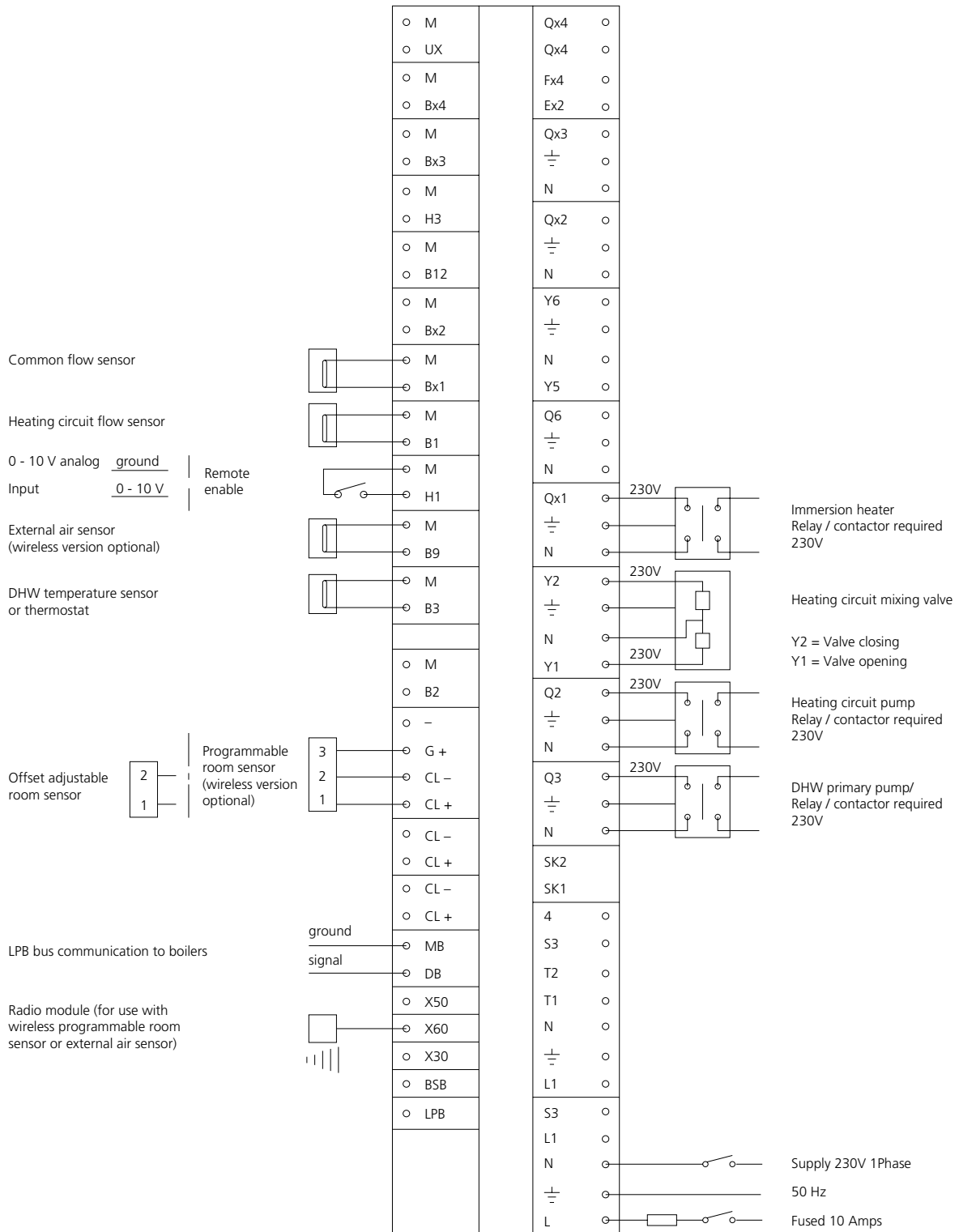



# Electrical Details

## Merley Boiler Sequence Controller

### Electrical Connections

Each sequence controller is provided with a full set of polarised push in screw terminal plugs that can only be fitted to the sequence controller in their correct position. Site wiring is made directly to the screw terminal plugs and the wall mounted housing, where specified, can be drilled and fitted with suitable glands allowing cable access to the sequence controller within.

### Power Supply

An independent isolator and fused electrical supply is recommended for the sequence controller. Supply 230 volt, 50Hz, single phase. Wiring external to the sequence controller must be installed in accordance with IEE Regulations and any local regulations which apply. Wiring must be completed in heat resistant 3 core cable, (size 1.0 mm<sup>2</sup> c.s.a.) External fuses should be rated 10 amps.

To prevent drawing excessive current (>10 amps) through the sequence controller, it is recommended that all pumps are connected via contactors.

### Sensor Cables

Non shielded 2 core cable may be used for connecting sensors directly to the sequence controller. Cable lengths and conductor cross sectional area (c.s.a.) requirements vary according to sensor type. See table below.

**Note:** Power supply cables should be routed separately to sensor cables observing a minimum spacing of 100mm.

### Pump And Mixing Valve Connections

Pumps requiring control from the sequence controller for the heating and hot water circuits must be connected via contactors to reduce electrical load drawn from the unit.

Mixing valves used within the heating circuit may be controlled directly from the sequence controller.

Outputs are rated 230 volts with maximum 2 amp load. The total combined output load for pumps and mixing valve must not exceed 10 Amps.

### Programmable Room Sensor

The hard wired programmable room sensor requires cables for both communication and power.

### Wireless External Air Sensor

A hard wired connection is required between the external air temperature sensor located outside and it's respective radio repeater module located inside the building, *see schematic on page 13.*

Non shielded 2 core cable may be used for connecting the external air sensor and the radio repeater module. Connections are not polarity sensitive.

Maximum cable length 5m  
Minimum conductor 0.5mm<sup>2</sup> c.s.a.

### Radio Module

The radio module is supplied complete with factory fitted cable, 1.5 metres, and polarised termination plug.

### Radio Repeater Module

The radio repeater module is supplied with a dedicated power supply transformer requiring a local isolatable standard 3 pin 230 volt plug socket. The transformer is supplied with a 3 metre power supply cable for the radio repeater module.

### LPB Bus Communication

Communication from the sequence controller to the boilers is via the LPB bus communication cable.

Shielded 2 core cable may be used for connecting the boilers with the sequence controller. Connections are polarity sensitive.

Maximum cable length 250m  
Minimum conductor 0.5mm<sup>2</sup> c.s.a.

### Recommended Cable Specification for Temperature Sensors

Sensor	Sensor Type	Sensor Ref.	Cable Function	Cable Type	Conductor c.s.a. mm <sup>2</sup>	Max. Length m	Polarity Sensitive
Common flow - water	Resistance	QAZ 36	Communication	2 core	1.5	120	No
DHW cylinder - water	Resistance	QAZ 36	Communication	2 core	1.5	120	No
Heating circuit - water	Resistance	QAZ 36	Communication	2 core	1.5	120	No
External air	Resistance	QAC 34	Communication	2 core	1.5	120	No
Offset adjustable room - air	Digital	QAA 55	Communication	2 core	0.5	200	Yes
Programmable room - air	Digital	QAA 75	Communication	2 core	0.5	200	Yes
	Digital		Power (12 V)	1 core	0.5	200	Yes

For resistance sensors, smaller cross sectional area conductors may be used with the following reductions in maximum cable length:

Conductor c.s.a. mm <sup>2</sup>	0.25	0.50	0.75	1.00	1.5
Maximum cable length	20	40	60	80	120



### **Customer Service Centre**

Hamworthy Heating Limited  
Fleets Corner, Poole,  
Dorset BH17 0HH

Telephone: **0845 450 2865**  
Email: **sales@hamworthy-heating.com**  
Web: **www.hamworthy-heating.com**

Hamworthy reserves the right to make changes and improvements which may necessitate alteration to the specification without prior notice.

500002524 A

### **Hamworthy Heating Accreditations**

ISO 9001 Quality Management System  
ISO 14001 Environmental Management System  
OHSAS 18001 Health & Safety Management System

The printed version of this brochure is produced  
using environmentally friendly print solutions  
in partnership with our suppliers

