

Chesil - Electronic Pressurisation Unit

Equipment For Commercial/Light Industrial
Central Heating Installations.

Installation, Commissioning and Servicing Instructions

IMPORTANT NOTE

**THESE INSTRUCTIONS MUST BE READ
AND UNDERSTOOD BEFORE INSTALLING,
COMMISSIONING, OPERATING OR
SERVICING EQUIPMENT**



Heating *at work.*

Customer After Sales Services

Telephone: **0845 450 2866** E-mail: **aftersales@hamworthy-heating.com** Fax: **01202 662522**

Technical Enquiries

To supplement the detailed technical brochures, technical advice on the application and use of products in the Hamworthy Heating range is available from our technical team in Poole and our accredited agents.

Site Assembly

Hamworthy offer a service of site assembly for many of our products in instances where plant room area is restricted. Using our trained staff we offer a higher quality of build and assurance of a boiler built and tested by the manufacturer.

Commissioning

Commissioning of equipment by our own engineers, accredited agents or specialist sub – contractors will ensure the equipment is operating safely and efficiently.

Maintenance Agreements

Regular routine servicing of equipment by Hamworthy service engineers inspects the safety and integrity of the plant, reducing the risk of failure and improving performance and efficiency. Maintenance agreements enable our customers to plan and budget more efficiently.

Breakdown service, repair, replacement

Hamworthy provide a rapid response breakdown, repair or replacement service through head office at Poole and accredited agents throughout the UK.

Spare Parts

A comprehensive spare parts service is operated from our factory in Poole, providing replacement parts for both current and discontinued products. Delivery of parts and components is normally from stock within seven days. However, a next day delivery service is available for breakdowns and emergencies.

CHESIL
Pressurisation Units
(Electronic Control)

**Installation, Commissioning
and Servicing Instructions**

**NOTE: THESE INSTRUCTIONS MUST BE READ AND UNDERSTOOD BEFORE
INSTALLING, COMMISSIONING, OPERATING OR SERVICING EQUIPMENT.**

**THE CHESIL - ELECTRONIC PRESSURISATION UNITS ARE INTENDED FOR USE ONLY
IN COMMERCIAL/LIGHT INDUSTRIAL APPLICATIONS.**

THESE PRESSURISATION UNITS COMPLY WITH THE ESSENTIAL REQUIREMENTS OF THE MACHINERY DIRECTIVE 89/392/EEC AMENDED BY 91/368/EEC, THE LOW VOLTAGE DIRECTIVE 73/23/EEC AMENDED BY 93/68/EEC AND THE ELECTROMAGNETIC COMPATIBILITY DIRECTIVE 89/336/EEC AMENDED BY 91/263/EEC AND 92/31/EEC.

**PUBLICATION NO. 500001181
ISSUE 'D'
AUGUST 2010**

CONTENTS

PAGE

1.0	INTRODUCTION	1
2.0	TECHNICAL DATA	1
3.0	SEALED SYSTEM FUNCTION	2
3.1	Terminology	2
3.2	Application	3
4.0	OPERATION OF THE PRESSURISATION UNIT	4
4.1	Unit Operation	4
5.0	GENERAL REQUIREMENTS	4
5.1	Related Documents	4
5.2	Mains Water Connections	5
5.3	Expansion Vessels	5
5.4	Safety Relief Valve	5
6.0	INSTALLATION	6
6.1	Location	6
6.2	Pipework Connections	6
6.3	Mains Connection	8
6.4	Electrical Connection To The User Terminals	8
6.5	Operation of the Controller	8
6.6	Trouble Shooting	8
6.7	Standard Menu Display	8
6.8	Maintenance Menu Display	9
6.9	Reset Menu Display	10
6.10	Alarms	10
6.11	Factory Default Settings	11
7.0	COMMISSIONING	12
7.1	Mechanical Installation	12
7.2	System Flushing	12
7.3	Electrical Installation	12
7.4	System Expansion Vessel	12
7.5	Initial Setting of Unit	13
7.6	Filling the Unit	13
7.6.1	User Defined Pressure Level Commissioning Apparatus	14
7.6.2	Cold Fill Pressure	14
7.6.3	Low Pressure Alarm	14
7.6.4	High Pressure Alarm	14
8.0	FAULT FINDING	15
9.0	SERVICING SCHEDULE	16
9.1	6 Monthly	16
9.2	12 Monthly	16
9.3	4 Yearly	16
10.0	SERVICING AND REPLACEMENT OF COMPONENTS	17
10.1	Hamworthy Heating Recommended Spares	17
10.2	Pump Replacement	17
10.3	Pressure Sensor Replacement	18
10.4	Replacement Of Control Box Assembly On Wall Mounted Unit	18
10.5	Replacement Of Controls PCB Wall Mount & Floor Standing Units	18
10.6	Replacement Of Display PCB Wall Mount Unit	19
10.7	Replacement Of Display PCB Floor Standing Unit	20
10.8	Low Water Level Switch Replacement	20
10.9	Inlet Valve Replacement	21
10.10	Non-Return Valve Replacement	21
10.5	Expansion Vessel Diaphragm Replacement	22
APPENDIX 'A' – Diagrams, drawings and Data		23

FIGURES**PAGE**

Figure 1	Part Numbers.....	1
Figure 2	Basic Overall Dimensions.....	1
Figure 3	Technical Data.....	2
Figure 4	Typical System Schematic Layout.....	3
Figure 5	Expansion Vessel Operation	3
Figure 6	Schematic Layout	4
Figure 7	Hamworthy Heating Expansion Vessels	5
Figure 8	Recommended Clearance Dimensions.....	6
Figure 9	Wall Mounting Bracket Dimension	6
Figure 10	Wall Mounting Pipework Dimensions	7
Figure 11	Floor Standing Pipework Dimensions	7
Figure 12	Restrictor Inserts	13
Figure 13	Changing Restrictor Inserts	13
Figure 14	Float Adjustment	13
Figure 15	Priming Screw	13
Figure 16	Pressure Level Adjustment Apparatus	14
Figure 17	Fault Finding Guide	15
Figure 21	Pump Removal	17
Figure 22	Pump Removal	17
Figure 24	Pump Removal	17
Figure 21	Pressure Sensor	18
Figure 22	Location Of Sensor.....	18
Figure 23	Control Box.....	18
Figure 24	Controller Terminals.. ..	18
Figure 25	Main Control PCB.....	19
Figure 26	Display PCB	19
Figure 27	Location Of Display PCB On Floor Standing Unit	20
Figure 28	Removal Of Inclined Panel.....	20
Figure 29	Disassembly Of Display PCB Enclosure	20
Figure 30	Assembly Of Display PCB In Enclosure.....	20
Figure 31	Level Switch In Tank	21
Figure 32	Level Switch Supplied As Spare.. ..	21
Figure 33	Non-Return Valve Assembly	21
Figure 34	Non-Return Valve Fitting Location On Pump	21
Figure A1	Wiring Diagrams	24
Figure A2	Heating System Calculation Sheet.....	25

1.0 INTRODUCTION

The WSE, FSE & FTE models in the Hamworthy Chesil range of pressurisation unit are designed to maintain the minimum pressure requirement of modern low/medium temperature, sealed central heating systems. The pressurisation units also provide replacement water for losses from the system.

Note! The pressurisation units are not to be used to fill the system from empty.

Model	Description	HHL Part Number
WSE	Wall Mount / Single Pump / Electronic Control	563216016
FSE	Floor Mount / Single Pump / Electronic Control	563216020
FTE	Floor Mount / Twin Pump / Electronic Control	563216021

Figure 1 - Part Numbers

The Chesil units are housed in a powder coated steel cabinet with removable cover. Housed in the cabinet is a pump, connecting pipe-work and pressure sensor. This sensor is connected to an electronic controller housed in a moisture proof enclosure. The controller switches the pump on or off to maintain the user defined pressure in the sealed system. In the top of the cabinet is the header tank, with a float valve to be connected to the water mains. The pump draws the make up water pressurising the system from this tank. In the wall mounted unit the user interface for the controller is accessed through the cut out in the front cover. On the floor mounted units the user interface is mounted within the inclined control panel at the top of the unit.

2.0 TECHNICAL DATA

All screw threads used in the Chesil units conform to **ISO 7/1** or **ISO 228/1** for pipe threads where applicable & **ISO 262** for all general screw threads.

The basic overall dimensions of the unit are shown in Figure 1 below. Performance and General Data is shown in Figure 2 (overleaf).

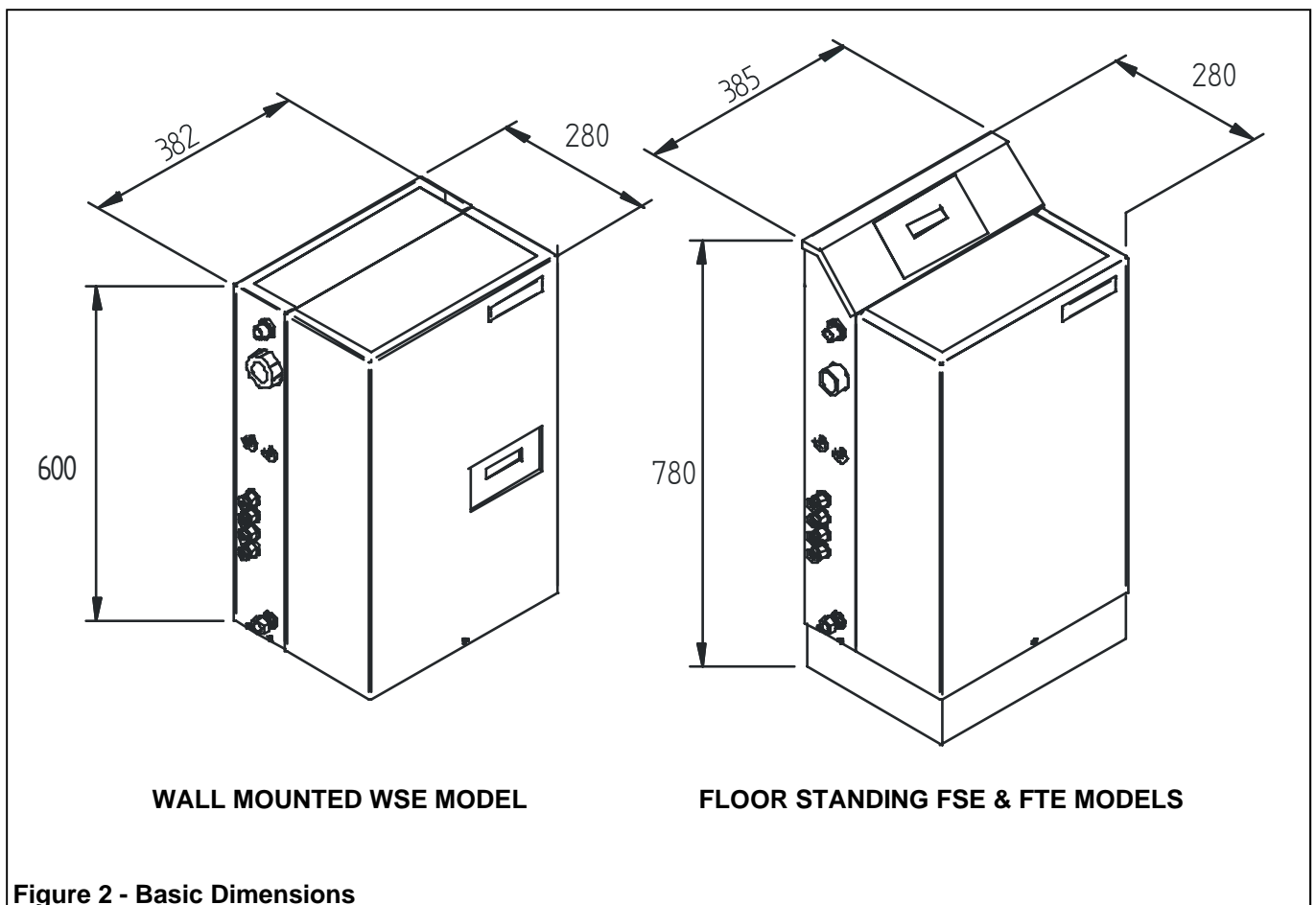

Figure 2 - Basic Dimensions

Figure 3 - Technical Data

		Floor Standing		Wall Mounted
Hamworthy Heating Part Number		563216020	563216021	563216016
Weight (empty)	kg	23	29	21
Weight (full)	kg	30.6	36.6	28.6
Tank capacity	litres	7.6		
Minimum cold fill pressure	bar	0.5		
Maximum cold fill pressure	bar	3.4		
Maximum operating pressure	bar	7.0		
Maximum Flow Rate	l/min	6		
Maximum water flow rate @ maximum cold fill pressure	l/min	0.1		
Factory Preset Values				
Cold fill pressure	bar	1.8		
System low pressure alarm	bar	1.3		
System high pressure alarm	bar	3.6		
To suit system conditions				
Maximum water flow temp	°C	82		
Maximum static height	m	16.5		
Minimum system operating pressure	bar	3.3		
Maximum system operating pressure	bar	7.0		
Safety relief valve setting (Not HHL supply)	bar	4.0		
Min. pressure differential	bar	0.2		
Electrical Data				
Alarm Relay Contact Rating		13A 230V AC		
Electrical Supply		230V AC 50Hz 1Ph		
Start current	amps	9		
Run current	amps	2.8		

3.0 SEALED SYSTEM FUNCTION

Figure 3 shows the layout of a typical sealed system.

3.1 Terminology

Expansion Vessel Charge Pressure:

- The gas pressure in the expansion vessel with water connection open to atmosphere.

System Cold Fill Pressure:

- The water pressure in the system that the pressurisation unit is set to maintain.

Figure 4 - Typical System Schematic Layout

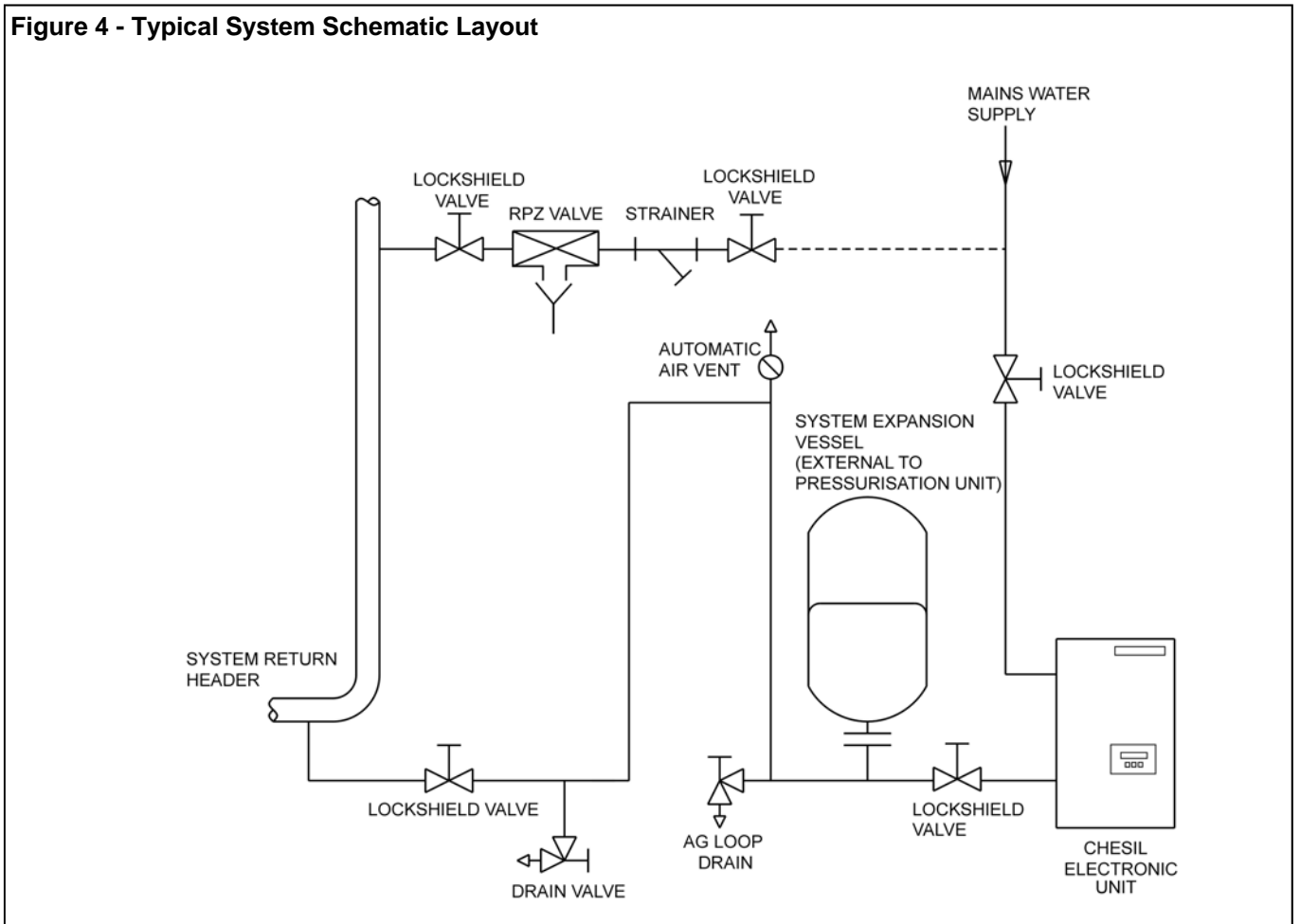

3.2 Application

The system expansion vessel charge pressure is set 0.1 bar below the cold fill pressure. Before operation of the boiler, with the system at cold fill pressure the expansion vessel is empty. As the system heats up the expanded volume is absorbed by the expansion vessel. A small pressure rise occurs which is accommodated by the vessel.

When the system cools the pressure drops. If there has been some fluid loss the pressurisation provides replacement.

Figure 5- Expansion Vessel Operation

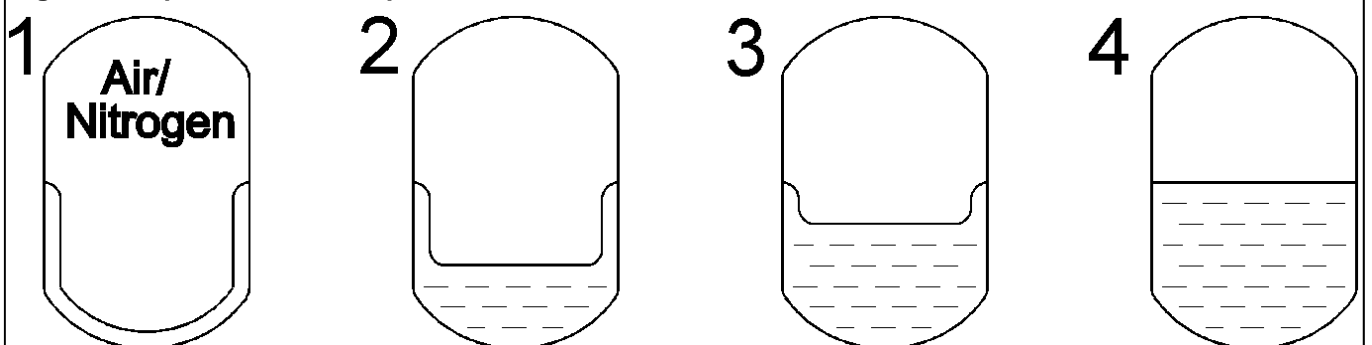

1. Diaphragm position at the cold fill / charge pressure. The vessel is empty of system fluid.
2. Diaphragm position at the hot working pressure. The system volume has expanded due to the temperature rise. The gas in the vessel is compressed. Acceptance factor = 0.35 maximum (recommended).
3. Diaphragm position at high system pressure. The boiler system is shut down by the system pressure switch on.
4. Diaphragm at the safety valve lift pressure. Caused by boiler temperature limiter failure for example. Acceptance factor = 0.5 maximum (recommended).

4.0 OPERATION OF THE PRESSURISATION UNIT

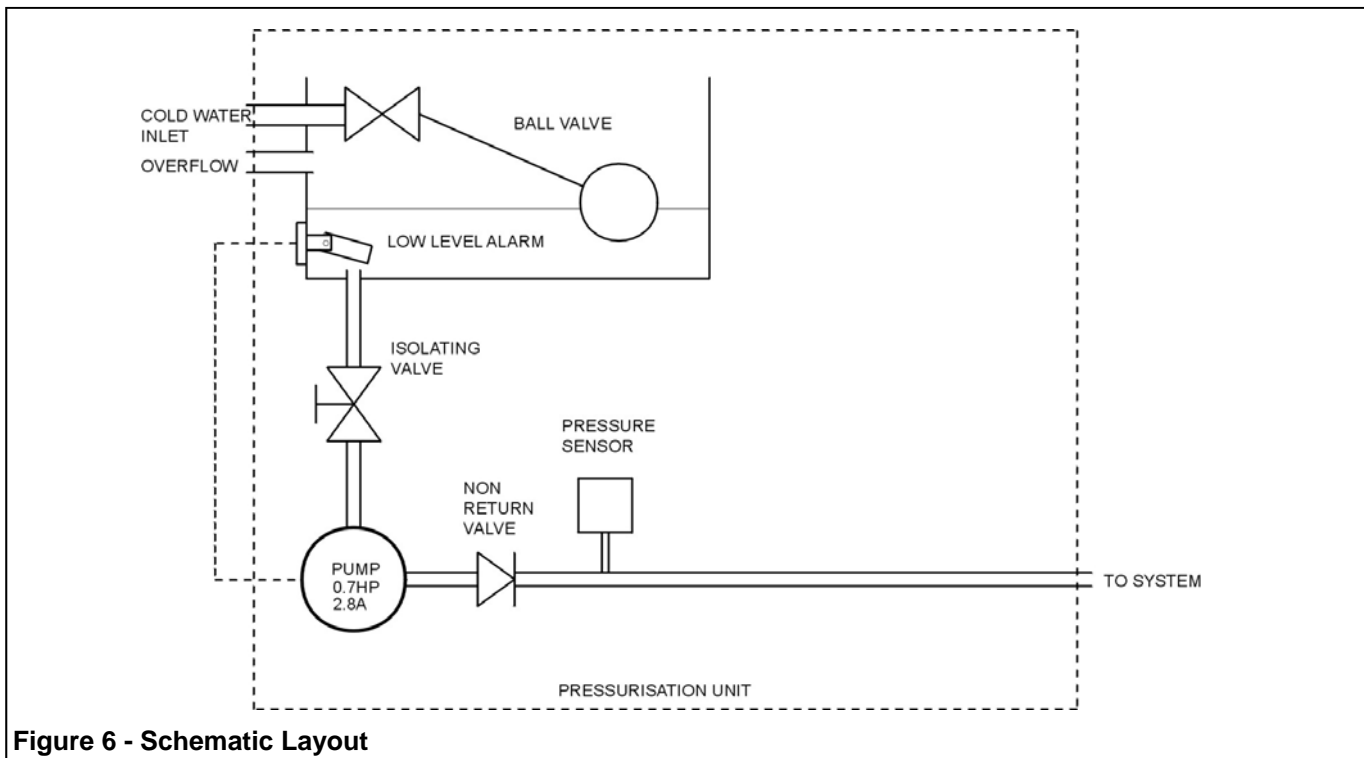

Figure 6 - Schematic Layout

4.1 Unit Operation.

The system pressure is continuously sensed by the pressure sensor in the pipe that connects to the heating system. This is linked electrically to the PU electronic controller, which converts the signal from the sensor to a pressure. The electronic controller checks this pressure against the user defined pressures to switch the pressurisation pump on and off, and activate low or high pressure alarm relays if reached. The controller can also determine the volume of water pumped into the system and compare this against user defined volumes to trigger a general alarm relay. The controller also records the total run time of the pump(s) (if the unit is fitted with a back-up pump), a user defined minimum run time can be set to stop the pump hunting when the on and off pressures are close together. The user can predefine the electronics to alternate between pumps (in a twin pump unit) to ensure that both pumps are optional. For small systems the user can select that the unit fills the heating system from empty. For commercial systems Hamworthy Heating Ltd recommends that this 'fill-function' is only used near the end of filling the system.

5.0 GENERAL REQUIREMENTS

5.1 Related Documents.

Pressure Systems and Transportable Gas Containers Regulations 1989.

It is the law that pressure system appliances are installed by competent persons in accordance with the above regulations. Failure to install appliances correctly could lead to prosecution. It is in your own interest and that of safety, to ensure that this law is complied with.

The installation of the pressurisation unit and expansion vessel **MUST** be in accordance with the relevant requirements of the Pressure System Regulations, Building Regulations, IEE Regulations and the bylaws of the local water undertaking.

It should also be in accordance with any requirements of the local authority and the relevant recommendations of the following documents:-

Applicable standards and documents are:

BS 7074 Application, selection and installation of expansion vessels and ancillary equipment for sealed water systems.

BS 6644 Installation of Gas Fired Hot Water Boilers 60 kW to 2 MW

BS 6880 Parts 1,2&3: Code of practice for low temperature hot water heating systems of output greater than 45 kW.

BS 6759 Part 1 (ISO 4126): Specification for safety valves for steam and hot water.

BS 3456 (CEE10 Part 1, CEE11 Part 1): Safety of Household and similar electrical appliances.

5.2 Mains Water Connections.

It is a requirement of the Water Supply (Water Fittings) Regulations 1999 that system is filled using an RPZ (Reduced Pressure Zone) valve with integral Type BA air gap. Information regarding the application, use and maintenance requirements for RPZ valves with Type BA air gap is available from WRAS. It is also advisable to contact the local water utility company to verify notification requirements for the use of these valves.

With the electronic model of Chesil pressurisation unit it is not always necessary to use an RPZ valve for system filling as the units have a Fill function suitable for small systems to a maximum of 200 litres. Where this fill function is used it is not necessary to have a quick fill loop using an RPZ valve.

5.3 Expansion Vessels.

System expansion vessels must be constructed to BS4814 or BS6144.

The required expansion vessel size is detailed in the contract documents. If in any doubt contact Hamworthy Heating Limited for comprehensive system sizing information. Hamworthy Heating Ltd supply a range of suitable expansion vessels, details are shown below. A calculation sheet which can be used to determine a suitable volume for an expansion vessel can be found in the Appendix.

Figure 7 - Hamworthy Heating Expansion Vessels

SALES REF NO.	HAMWORTHY PART NO.	TYPE	TOTAL VOL. LITRES	DIAPHRAGM PART NO.	CONNECTION DETAILS	WT kgs
HOT WATER APPLICATIONS - EPDM DIAPHRAGM (0-100°C MAX)						
HAF 24V	532712082	VERTICAL	24	532712083	R¾ BSPT MI	3.6
HAF 60V	532712002	VERTICAL	60	532712030	R1 BSPT MI	13
HAF 80V	532712003	VERTICAL	80	532712031	R1 BSPT MI	14
HAF 100V	532712004	VERTICAL	100	532712032	R1¼ BSPT MI	15
HAF 200V	532712005	VERTICAL	200	532712033	R1¼ BSPT MI	40
HAF 300V	532712006	VERTICAL	300	532712034	R1¼ BSPT MI	50
HAF 500V	532712007	VERTICAL	500	532712035	R1¼ BSPT MI	80
HAF 750V	532712008	VERTICAL	750	532712036	R1½ BSPT MI	120
HAF 1000V	532712009	VERTICAL	1000	532712037	R1½ BSPT MI	150
HAF 1200V	*	VERTICAL	1200	*	R1½ BSPT MI	530
HAF 1600V	*	VERTICAL	1600	*	R1½ BSPT MI	10
HAF 2000V	*	VERTICAL	2000	*	R1½ BSPT MI	700
* REFER TO HAM-WORTHY HEATING						
HAF 8	532712056	H/V	8		R¾ BSPT MI	
HAF 16	532712057	H/V	16		R¾ BSPT MI	
HAF 60H	532712011	HORIZONTAL	60	532712030	R1 BSPT MI	14
HAF 80H	532712012	HORIZONTAL	80	532712031	R1 BSPT MI	15
HAF 100H	532712013	HORIZONTAL	100	532712032	R1¼ BSPT MI	16
HAF 200H	532712014	HORIZONTAL	200	532712033	R1¼ BSPT MI	41
HAF 300H	532712015	HORIZONTAL	300	532712034	R1¼ BSPT MI	51

5.4 Safety Relief Valve.

Must comply with BS6759 part 1, and be sized and installed in accordance with BS6644 & BS7074.

6.0 INSTALLATION

The units are supplied inside strong cardboard boxes with paper padding and should be left in this packaging until they arrive on site and are installed.

6.1 Location

The units are designed for both wall mounting and floor standing. A mounting bracket is supplied inside the unit taped to the front of the tank for wall mounting. It is intended that this bracket should be fixed to the wall and the unit hung from it. Each unit also has two holes in the back of the chassis for extra security. The corresponding holes in the wall should be drilled to suit once the unit is mounted on its bracket.

The bracket dimensions are shown in fig 9 below.

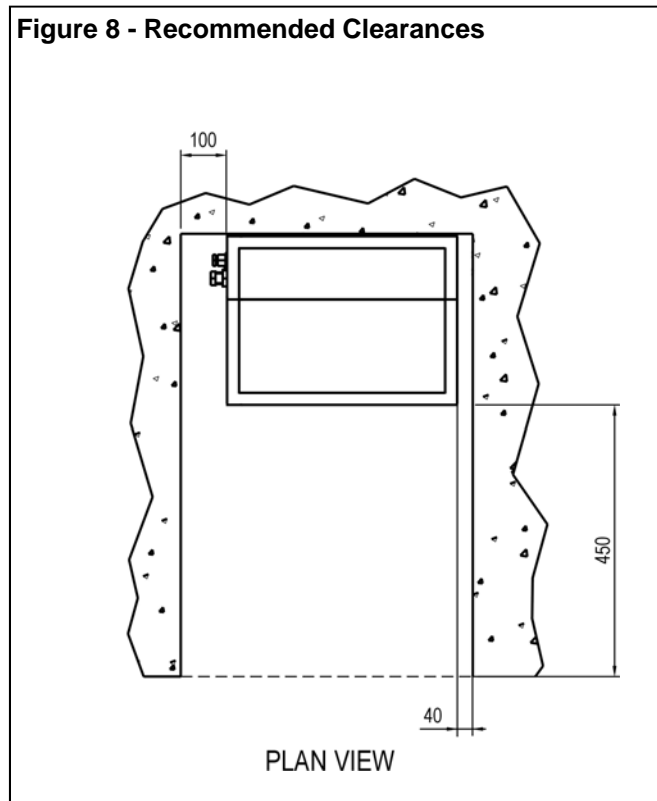

6.2 Pipework Connections (Shown in Figure 10)

1) Mains water connection ($\frac{1}{2}$ " BSP Male).

The units have a type 'AF' air gap to prevent backflow in accordance with Water Supply (Water Fittings) Regulations 1999. The water supply connection must conform to all local WRAS regulations.

2) Plastic Overflow Connection (D32mm Bore Plastic Waste Pipe).

Overflow should be piped to where it will be safe but visible so it will be noticed and can be modified.

3) System connection.

The system connection is via a 15MM compression fitting. The unit must be connected to the system by an antigravity loop (see Figure 3). The antigravity loop must be made in pipe-work no smaller than the expansion vessel connection, and have a minimum height of 2 metres. It should include a lock-shield (or lockable) valve at the system connection point for servicing and an automatic air vent fitted at the highest point of the loop. The antigravity loop must not be lagged but can be fitted with an optional kit to prevent freezing. Consult Hamworthy Heating for details. The pipe-work and fittings must be pressure tested to 1.5 times the safety valve lift pressure.

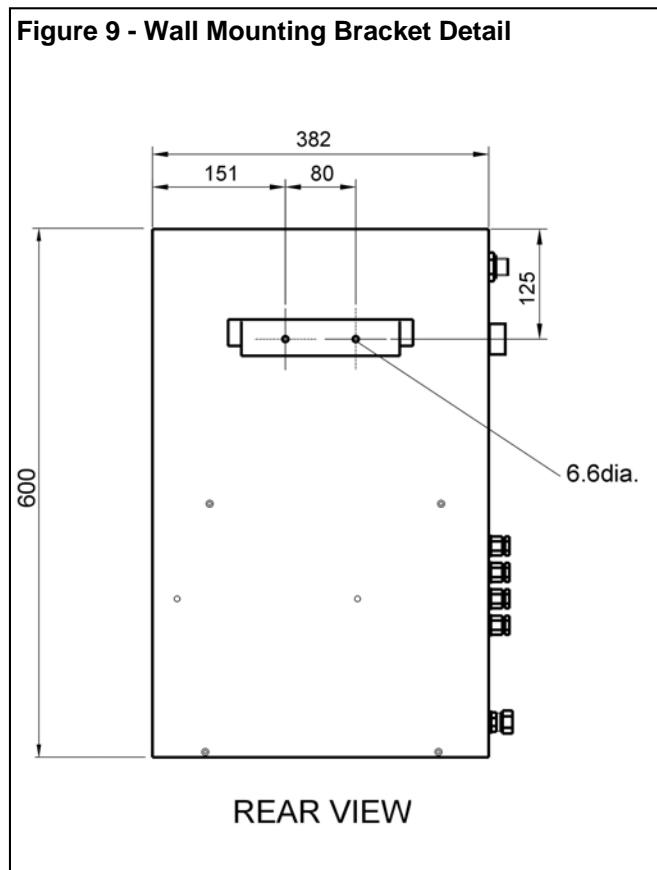

Figure 10 - Pipework Connections (Wall Mounted)

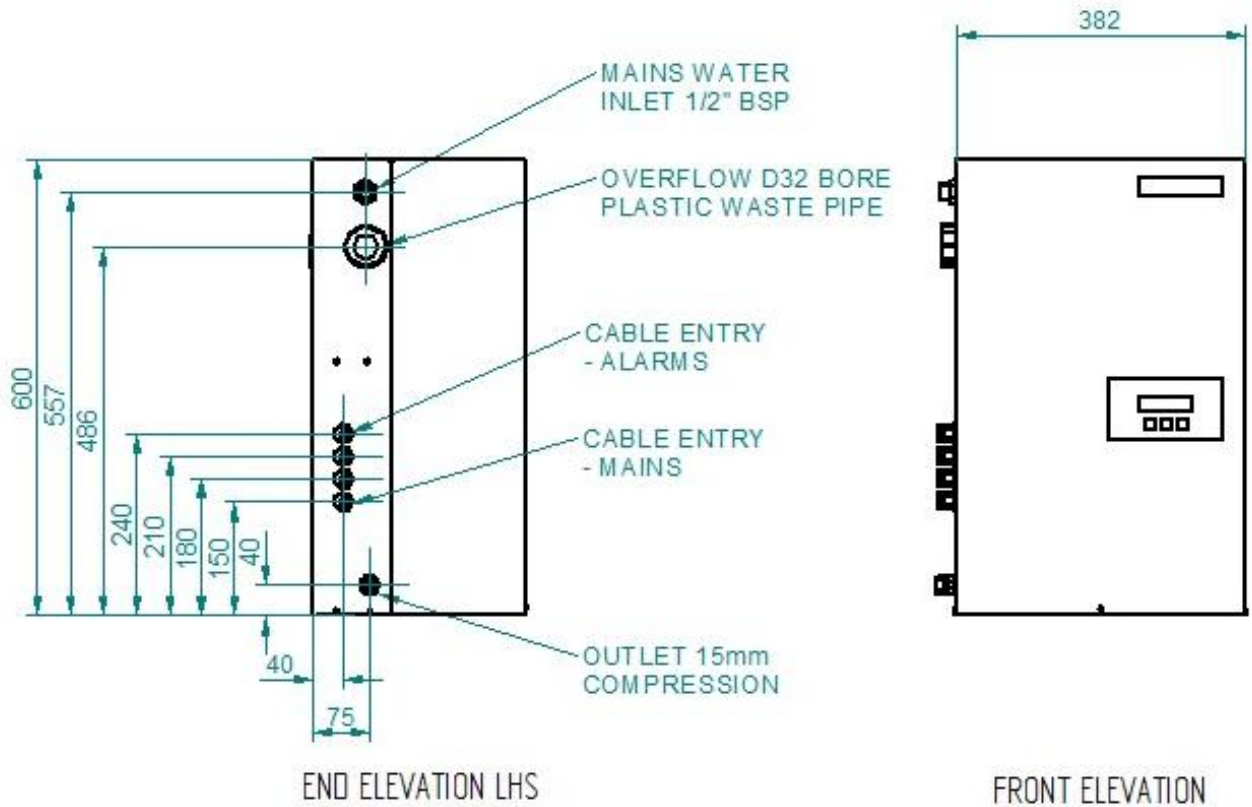
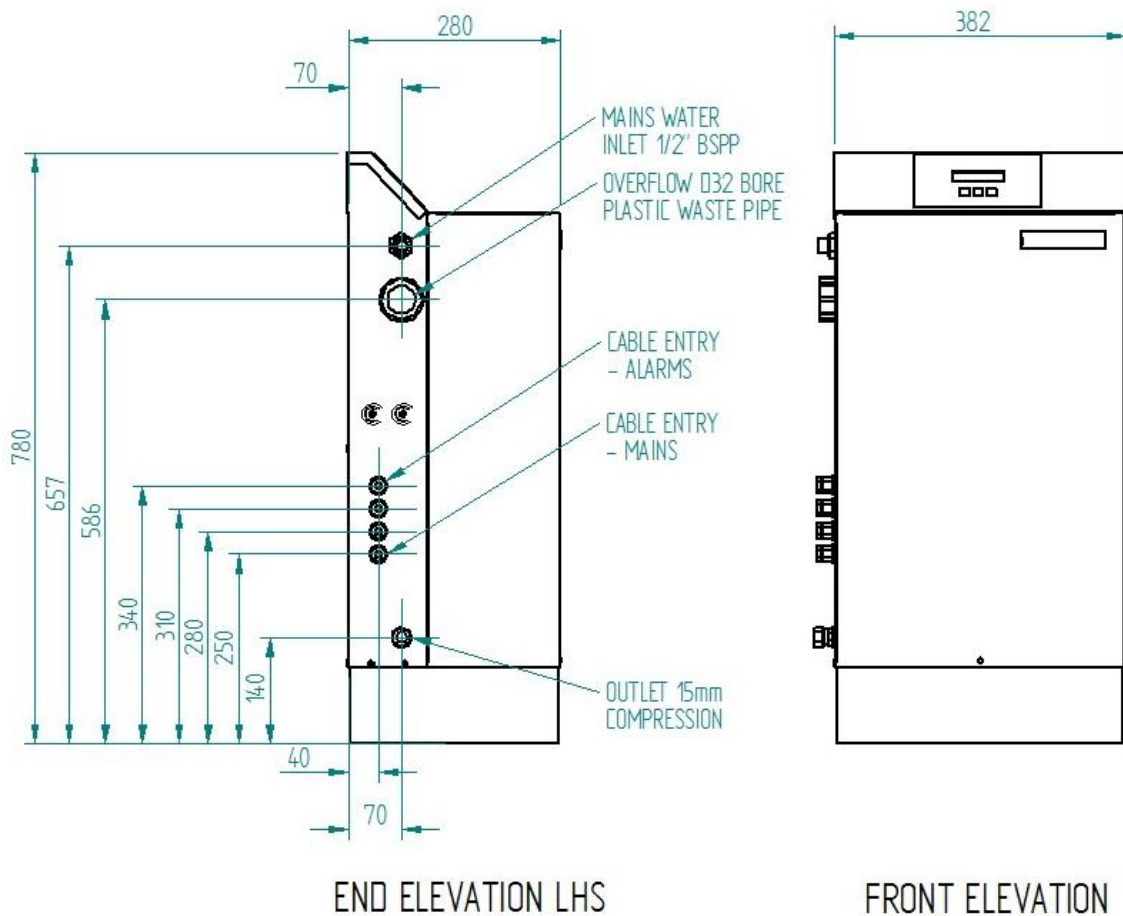

Figure 11 - Pipework Connections (Floor Standing)



6.3 Electrical connection.

Wiring diagrams for the units can be found in appendix A1. All wiring to the pressurisation unit must be in accordance with the IEE regulations, and any local regulations which apply. **Note! If in any doubt a qualified electrician should be consulted.**

6.3.1 Mains Connection

Units are supplied fitted with a 1m flying lead for connection to the mains supply. Mains connection must be via a fused isolator rated at 13 Amps and positioned locally to the unit.

6.4 Electrical Connection To The User Terminals (see Fig A1).

Terminals 1 to 3 are Low Pressure Alarm volt free relay - 1 Normally Open, 2 Common and 3 Normally Closed. Suitable for up to 230V 0.5A connection.

Terminals 4 to 6 are High Pressure Alarm volt free relay - 4 Normally Open, 5 Common, 6 - Normally Closed. Suitable for up to 230V 0.5A connection.

Terminals 7 to 9 are General Alarm volt free relay - 7 Normally Open, 8 Common 9 - Normally Closed. Suitable for up to 230V 0.5A connection.

Terminals 12 and 13 are for mains supply to Pump Two (if fitted) - 12 Pump Two Neutral connection and 13 Pump Two Live connection. Pump to be suitable for supply of 230V single phase 50Hz.

Terminals 10 & 11 are for mains power coming into power electronics - 10 Live & 11 Neutral connection. Supply to be 230V single phase 50Hz.

The unit comes with sensor cable fitted and has been calibrated, and therefore must not be adjusted in any way.

6.5 Operation of the Controller

Once wired, cover closed, and cable fitted to pressure sensor, the unit is ready for operation. When the mains supply is switched on the unit becomes operational with factory settings applying.

After a few seconds the unit will become operational and will start the pump(s) until pre-set pressure has been achieved or until an alarm is displayed (other than Low Pressure Alarm). Please note, however, there is a fill function in the Maintenance menu designed to bring the system up to pre-set pressure which will ignore counters such as volume of water introduced, pump cycle count, hours run meter etc. See Maintenance menu for more information.

Once system is in normal operation mode the word 'AUTO' appears, to indicate that the unit is in working mode. The display will always revert to this unless it is in alarm condition.

6.6 Trouble Shooting

In the event of the unit not coming on when mains is applied, then please return the unit to HHL for full investigation.

Once powered up, the unit will become operational. Again, if the unit is not operating as you believe it should, then please contact HHL Technical Department for further assistance.

6.7 Standard Menu Display

By pressing the up and down keys you can scroll up and down the standard menu in the order detailed below. All items in menu are view only, except for Cut-out Pressure which can be altered by user between 0.7 Bar and 6.0 Bar in 0.1 Bar steps. By altering the cut-out pressure, cut-in pressure and low pressure alarm setting will move by same amount as cut-out pressure is moved either up or down, unless they hit their minimum. High pressure alarm setting will move upwards once cut-out pressure is 0.2 Bar below high pressure alarm, but will not move downwards if cut-out pressure is brought down.

The structure of the standard menu is as follows and can be scrolled through by using the up and down keys:-

SYSTEM PRES X.X: This is current pressure reading of system in Bar.

CUT OUT PRES X.X: This is the pump cut-out pressure.

MAKE-UP V0 XXXX: This is volume of water introduced into system in litres since the unit was last reset.

MAKE-UP ALARM XX: This is alarm setting of volume of water introduced since Make-up V2 was last reset in 10's of litres (i.e. 23 would mean 230 Litres).

MAKE-UP V2 XXX.X: This is volume of water introduced into system in litres since make-up V2 was last reset.

PUMP OPS XXXX: This is the total number of pump cycles since pump ops was last reset.

PUMP1 HRS XX.XX: This is Pump 1 hours run since Pump1 Hrs was last reset.

PUMP2 HRS XX.XX: This is Pump 2 hours run since Pump 2 Hrs was last reset.

6.8 Maintenance Menu Display

This is obtained by switching off power to the unit, making sure screen has gone blank and then pressing down left hand button whilst reconnecting power to the unit.

Under Maintenance Menu you obtain access to normal menu, plus added functions, with the facility to make adjustments where appropriate. Structure of menu is as follows and can be scrolled through by using the up and down keys:-

SYSTEM PRES X.X: This is current pressure reading of system in Bar. This item is non-adjustable - view only.

CUT-OUT PRES X.X: This is the pump cut-out pressure in Bar. This is settable from 0.7 to 6.0.

When moving cut-out pres, cut-in pres and low pres alarm will move in line and will always keep same differential (e.g. if cut-out pres starts at 1.8, cut-in pres at 1.4 and low pres alarm at 1.2, and then cut-out pres was moved to say 2.5, then cut in pres would become 2.1 and low pres alarm 1.9), except when cut-in pres and low pres alarm reach their maximum.

When moving cut-out pres upwards, high pres alarm will also move upwards, but only once 0.2 Bar above the current setting (e.g. if cut-out pres was moved to 4.1 then high pres alarm will automatically become 4.3 if not already higher). High pres alarm will not move downwards when cut-out pres is moved down.

MAKE-UP VO XXXX: This is volume of water introduced into system in litres since the unit was last reset.
This item is non-adjustable - view only.

MAKE-UP ALARM XX: This is alarm setting of volume of water introduced since make-up V2 was last reset in 10's of litres (i.e. 23 would mean 230 Litres).

This is settable from 1 (10) to 99 (990)

This is used to set off General Alarm to warn that the unit has introduced a certain amount of water. For instance if set to 23, the alarm will go off once the system has introduced 230 litres of water since make-up V2 was last reset and the unit will be frozen and will not resume its normal function until make-up V2 is reset or make-up alarm is moved higher than make-up V2 reading (divided by 10).

MAKE-UP V2 XXX.X: This is volume of water introduced into system in litres since make-up V2 was last reset.
By pressing the enter button this will be reset

to 000.0

PUMP OPS XXXX: This is the total number of pump cycles since pump ops was last reset.
By pressing the enter button this will be reset to 0000.

PUMP1 HRS XX.XX: This is Pump 1 hours run since pump 1 hrs was last reset.
By pressing the enter button this will be reset to 00.00

PUMP2 HRS XX.XX: This is Pump 2 hours run since pump 2 hrs was last reset.
By pressing the enter button this will be reset to 00:00.

CUT IN PRES X.X: This is Pump cut-in pressure in Bar.

This is settable from 0.5 to 5.8

Cut in pres automatically moves up and down when cut out pres is moved and will always keep same differential it had before cut out pres was moved, except when cut in pres reaches minimum.

However, cut in pres can be adjusted here. It will only go upwards until 0.2 Bar below cut out pres setting. When moving the setting down, low pres alarm will automatically move downwards once 0.2 Bar below cut in pres.

L PRES ALARM X.X: This is Low Pressure Alarm setting in Bar.

This is used to set off Low Pressure Alarm Relay to warn that system is below desired minimum pressure.

This is settable from 0.0 to 5.6.

Low pres alarm automatically moves up and down when cut out pres is moved and will always keep same differential it had before cut out pres was moved, except when low pres alarm reaches minimum. Low pres alarm will also move down when 0.2 Bar below cut in pres, when cut in pres is moved downwards and will keep 0.2 Bar difference once this has been reached.

However, low pres alarm can be adjusted here but can never move higher than 0.2 Bar below cut in pres setting.

H PRES ALARM X.X: This is High Pressure Alarm setting in Bar.

This is used to set off High Pressure Alarm Relay to warn that system is above desired maximum pressure.

This is settable from 0.9 to 6.2

High pres alarm will move up when 0.2 Bar above cut out pres, when cut out pres is moved upwards and will keep 0.2 Bar difference once this has been reached. However, high pres alarm can be adjusted here but can never move lower than 0.2 Bar above cut out pres setting.

PUMP MIN RUN X.X: This is Pump Minimum run time in seconds.

This is settable from 1.0 to 9.9

This function can be used to stop hunting when cut in pres and cut out pres are very close together.

PUMP MAX RUN X.X: This is Pump maximum run time in minutes.

This is settable from 01 to 99

PUMP DELAY XX: This is Pump minimum cycle time in minutes.

This is settable from 00 to 99

By entering a setting in here it will prevent the pumps cycling until desired time has elapsed.

PUMP KICK XX: This is Pump Duty cycle time in days.

This is settable from 00 to 99.

This function will run the pump for 1 second every XX days. This function is used to run the pumps periodically.

PUMP : This is a Pump Selection function and is displayed as XXXXX.

There are three settings:-

PUMP1. Will only call on pump 1 to operate (cuts out Pump 2)

PUMP2. Will only call on pump 2 to operate (cuts out Pump 1)

ALTERNATE. Will automatically cycle from Pump to Pump taking into consideration the pump delay setting. In the event of a Pump failure, unit will keep on working with one working pump when in ALTERNATE pumps mode.

PASSCODE XX: This is Passcode function.

This is settable to y or n

When set to y, any changes wishing to be made to any setting will need the pass number entered in.

PUMP TIMEOUT XX: This is pump failure setting in minutes.

This is settable from 01 to 99.

This is used by electronics to determine whether a pump has 'failed'. The electronics will monitor the pressure when the pumps are on and if the pressure is not seen to rise by 0.05 Bar during this pump timeout setting then it will declare the pump as having failed. This doesn't actually mean the pump is working as there may be other reasons for the pump not increasing the pressure, but indicates that the unit/system should be checked.

FILL: This is a Fill function and is activated by pressing the enter key.

This function is used for final top up to bring up system to required pressure whilst disabling all counters (I.e. MAKE-UP V0, MAKE-UP V2, PUMP OPS, PUMP1 HRS, PUMP2 HRS will not be altered). The system will bring up the system to cut out pressure if reached within 6 hours and the unit will then stop and FILL will flash on the screen. To return the unit back to normal operation the enter key needs to be pressed again.

Once any required modifications have been made under Maintenance Menu, it is advisable to revert back to normal menu by switching off the power to the unit, making sure screen has gone blank, and switching power back on. No information is lost by doing this and all last entered settings will remain. This will then restrict amendments again to cut out pressure setting (see Standard Menu).

6.9 Reset Menu

The unit can be completely reset to factory default settings, clearing all changes made by switching off the power to the unit, making sure screen has gone blank, then pressing both the left hand and middle buttons whilst re-establishing power.

NOTE: By doing this all settings and counters will be lost and the unit will revert back to factory default settings.

When carrying out a full reset, the normal and maintenance menus appear along with two further settings as follows:-

OFFSET PRES XX: This is pressure reading raw data in hexadecimal steps and is not adjustable. It is used for setting the pressure offset and span potentiometers. This will have already been set at factory and there should be no requirements to use this reading.

PUMP CURRENT XX: This is pump current draw data in hexadecimal steps and is not adjustable. This is used by the electronics to establish a pump failure and there should be no requirement to use this reading.

Once the unit has been reset for normal operation, it is advisable to revert back to the standard menu by switching off the power to the unit, making sure screen has gone blank, and switching it back on. No information is lost by doing this and all last entered settings will remain. This will then restrict amendments again to cut out pressure setting (see Standard Menu).

6.10 Alarms

There are a number of alarms and the unit will always default to alarm display when one is in activation. The unit will flash when in alarm mode to indicate that

there is a problem. If more than one alarm is tripped then the system will display all alarms currently affecting the unit - the unit will flash each alarm for a couple of seconds before showing the next one, and will continue to scroll through the list. When any condition has been rectified the unit will continue to display any other current alarms that still affect the system. Only when all alarm faults have been rectified, will the unit go back to Auto mode.

The alarms are as follows:-

ALARM-LO PRESS: This indicates that Low Pressure Alarm has been breached. The unit will continue to operate under this alarm function, but invariably the alarm will be caused by some other problem (e.g. too long a t3 setting).

ALARM-HI PRESS: This indicates that High Pressure Alarm has been breached. The pump control will be discontinued until the alarm fault has been rectified.

ALARM-LEAK LIMIT: This indicates that Leakage Volume Limit has been breached. The pump control will be discontinued until the alarm fault has been rectified. This can be done by resetting Leakage Volume to 0, or by increasing make-up alarm above make-up V2.

ALARM-TANK LEVEL: This indicates that the water level in the water tank is too low. The pump control will be discontinued until the alarm fault has been rectified.
Investigate reasons why water content of tank is low.

FAULT PUMP1: This indicates that Pump 1 has drawn over the allowed current and is possibly at fault. You can press enter when this displays, and the pump will come back into service if it is working. It is worth running Pump 1 to ascertain if it is faulty or not.

FAULT PUMP2: This indicates that Pump 2 has drawn over the allowed current and is possibly at fault. Same remedy as for FAULT PUMP1 alarm.

PUMP1 TIMED OUT This indicates that Pump 1 has not increased the pressure in the system within the allowed time setting. You can press enter when this displays, and the pump will come back into service if it is working. It is worth running Pump 1 to ascertain if it is faulty or not. If this problem persists and the pump is still working, then pump timeout setting should be increased.

PUMP2 TIMED OUT: This indicates that Pump 2 has not increased the pressure in the system within the allowed time. Same remedy as for Pump 1 Timed Out alarm.

There are volt free relays on the unit to give audible, visual or BMS signals that the unit has gone into alarm mode. The Low and High Pressure Alarms have their own circuits, with all other conditions setting off General Alarm relay.

6.11 Factory Default Settings

The unit is supplied with the following default settings, which will also be reverted to if the unit is completely reset:-

CUT OUT PRES	1.8
MAKE-UP V0	0000
MAKE-UP ALARM	99
MAKE-UP V2	000.0
PUMP OPS	0000
PUMP1 HRS	00:00
PUMP2 HRS	00:00
CUT IN PRES	1.5
L PRES ALARM	1.3
H PRES ALARM	3.6
PUMP MIN RUN	1.0
PUMP MAX RUN	99
PUMP DELAY	00
PUMP KICK	30
PUMP SELECTOR	ALERNATE PUMPS
PASSCODE	n
PUMP TIMEOUT	03

Technical Summary

Voltage Supply:	230V 1~ 50Hz Mains Current rated at 690W
Maximum Working Voltage:	250V
Fuse Rating:	13A
Temperature Range:	4°C to 65°C
Housing Classification:	IP65

7.0 COMMISSIONING

Chesil Electronic Units are supplied factory set and tested to suit the system parameters shown in Figure 2. If the application falls within these parameters the unit requires minimal commissioning checks.

7.1 Mechanical Installation.

Check that the Chesil Unit and expansion vessel has been installed correctly, as detailed in section 6.2: Pipe-work connections.

7.2 System Flushing.

Ensure that the system has been flushed and all foreign matter has been removed, including pipe scale.

Note! Should this material come into contact with the expansion vessel diaphragm it could result in premature failure of the expansion vessel assembly.

7.3 Electrical Installation.

Before working on Chesil units ensure the electrical supply & external circuits connected to the unit are isolated.

7.4 System Expansion Vessel.

To set or check the expansion vessel charge pressure the lock-shield valve between the Chesil unit and the vessel must be closed. The drain cock fitted on the base of the expansion vessel must be open to allow any water in the vessel to escape.

A suitable gauge should be used to check the charge pressure. Generally a Schrader 'car type' valve is fitted near the top of the expansion vessel. If the charge pressure is too high it can be reduced by depressing the centre of the Schrader valve or by using a pressure gauge with an integral air release valve. If the charge pressure is too low a small increase can be provided using a car foot pump otherwise an oil free compressor or nitrogen bottle is recommended.

Note! The expansion vessel charge pressure should be set to 0.1 bar less than the cold fill pressure.

When the correct pressure is set the Schrader valve protective cap must be replaced.

Check the integrity of the pipe-work. Ensure the lock-shield valve between the Chesil unit and the expansion vessel is open and the drain valve is closed. Ensure the air purge plug is fitted (near the top of the expansion vessel).

7.5 Initial Setting of Unit

Each unit comes with a selection of inserts that can be fitted into the inlet valve to achieve the required output:

Mains inlet pressure > 4 bar H.P. restrictor (white see fig 12)

Mains inlet pressure < 4 bar L.P. restrictor (red see fig 12)

The HP restrictor is fitted in the inlet side of the float valve assembly. This should be unscrewed in order to change the restrictor (see fig 13). The LP Restrictor is clipped to the side of the valve assembly.



Figure 12 - Restrictor Inserts



Figure 13 - Changing Restrictor Inserts

3) If the cold water is from a tank then the tank must be at least 2m above the inlet for the header tank to remain full when the pump is working at maximum rate. The pressurisation units should not be used to fill a heating system.

4) Check that the unit has been connected to the system using a suitable isolation valve.

5) Check that the mains lead has been connected to a suitably fused and switched isolator.

6) The cold fill pressure on the units are factory set to the levels listed in figure 3 as are the Hi, Lo pressure alarm. If these levels are unsuitable for the installation then adjustment will be necessary.

7) Set the float to its lowest level. (fig 14)

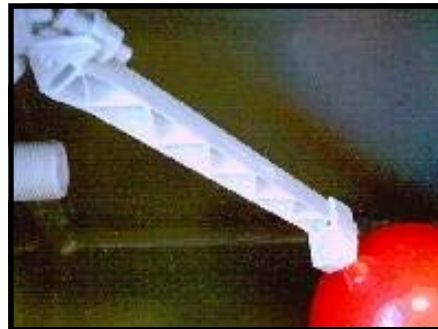

Figure 14 - Float Adjustment

7.6 Filling The Unit

1) Check all connections and pressures. Remove front cover by unscrewing securing screw at base of unit and lifting cover up and slide forwards.

2) Undo the priming screw on pump head (fig 15). Prime until fluid appears. Close the screw & turn on the supply to the unit (keeping system isolation valve closed). Pump will run for a few seconds until set pressure is reached.

3) Check for any leaks within the unit, if OK open system isolation valve.

4) The unit will now monitor the system and keep it at the required pressure.



Figure 15 - Priming Screw

7.6.1 User Defined Pressure Level Commissioning Apparatus

When commissioning, the unit must be set up with the apparatus similar to that shown in Figure 16 connected to the outlet.

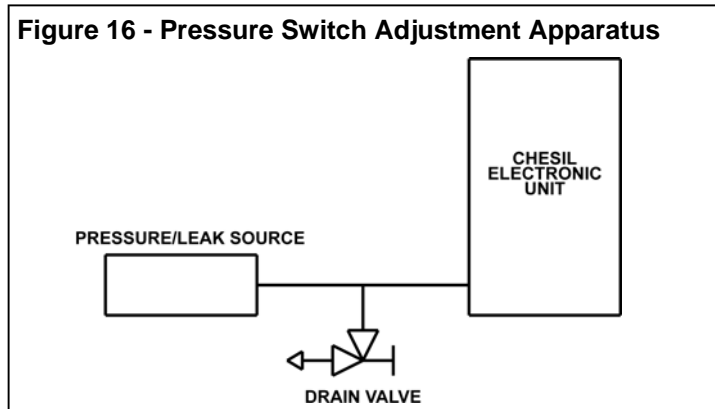

7.6.2 Cold Fill Pressure

Designed to stop the pump when pressure reaches a preset level. Setting procedure as follows:

- 1) Ensure the system pressure is lower than the user defined pressure is to be set to.
- 2) Switch the unit on.
- 3) Introduce a small leak at the outlet via the drain valve.
- 4) Because of the leak the unit begins a cycle of starting and stopping. Adjust the cold fill pressure value until the pump starts at 0.2 bar below the required cold fill pressure.

7.6.3 Low Pressure Alarm

Designed to stop the boiler operating if the pressure falls below a preset level. Setting procedure as follows:

- 1) Set the cold fill pressure by following the procedure in section 7.7.2 & allow system to run to pressure.
- 2) Isolate the units Low Pressure Alarm from the boiler circuit and connect a multi-meter to the terminal of the alarm.
- 3) Introduce a small leak until the system pressure reading equals the required Low pressure setting.
- 4) Stop the leak.
- 5) Set the low pressure alarm to the desired level and adjust the level until the multi-meter across the terminals of the alarm signals a change in state.
- 6) Reconnect the Chesil unit to the boiler circuit.

7.6.4 High Pressure Alarm

Designed to stop the boiler operating if the pressure exceeds a preset level. Setting procedure follows:

- 1) Isolate the High Pressure Alarm relay from the boiler circuit and connect a multi-meter to the terminals of the alarm relay.
- 2) Fill the system from the mains water supply until the system pressure reads the required high pressure.
- 3) Set the high pressure alarm to the desired level and adjust the level until the multi-meter across the terminals of the alarm signals a change in state.
- 4) Reconnect the Chesil unit to the boiler circuit.

Figure A1 in appendix shows the wire colours of the switches.

8.0 FAULT FINDING

General fault finding is shown in Figure 18. If the Weymouth unit still does not operate satisfactorily, consult Hamworthy Heating for assistance.

Figure 17. Fault Finding Guide.

Fault	Possible Causes	Action
Pump will not run	Unit up to pressure No power to the unit Isolator fuse blown Cut In Pressure set incorrectly Pump seized or faulty	None Check at source Replace fuse in isolator. Note! Investigate cause of blown fuse before restarting the unit Adjust cut in pressure (see section 6.5) Service or replace pump (see section 10)
Pump runs but will not build up pressure	Pump isolating valve closed Pump not primed Float switch faulty Pump non return valve jammed	Open valve (see fig 21) Prime pump (see section 7.6) Check water level and replace float switch. Check valve
Pump cuts in and out rapidly (hunting)	Value of cut in & cut out pressure set incorrectly Non return valve not sealing correctly System Leak	Adjust values Clean valve seat or replace valve if necessary (see section 10.4) Trace leak and ensure system is sound
Pump runs continuously	Value of cut out pressure set incorrectly Pump relay faulty System leak	Adjust value Replace faulty relay PCB in grey box (see section 10.5) Trace leak and ensure system is sound
Pump cuts out at wrong pressure	Pressure gauge being compared with is inaccurate. Internal pressure sensor faulty.	Replace pressure gauge. Replace pressure sensor (see section 10.6)
Maximum system working pressure too high	Cut out pressure set incorrectly Internal pressure sensor faulty.	Adjust value. Replace pressure sensor (see section 10.6)
Boiler switches off unexpectedly	Hi or lo pressure alarms set incorrectly Safety circuit is wired incorrectly	Adjust values. Check wiring with Wiring diagram in appendix
System pressure runs consistently at cold fill pressure	Small system leak	Trace leak and ensure system is sound.

9.0 SERVICING SCHEDULE

The following is a recommended servicing schedule for the Chesil unit and expansion vessel. If remedial action is required, refer to section 10: SERVICING AND REPLACEMENT OF COMPONENTS. If in doubt consult Hamworthy Heating.

9.1 6 Monthly

1) Check the expansion vessel charge pressure, as described in section 7.4. A significant drop in charge pressure could be due to a faulty vessel diaphragm; replacement of diaphragm should be considered. See section 10.9.

2) Check the value for PUMP KICK. Adjust if necessary then briefly reduce the system pressure to check for rotor seizure. This could occur if the pump is not run for extended periods. This can be accomplished by slightly opening the expansion vessel drain valve to initiate a leak.

Note! Ensure that the drain valve is closed after this operation.

9.2 12 Monthly

1) Check the ball float valve diaphragm seat for integrity and replace if necessary. Also check the plastic float for soundness.

2) Check the expansion vessel for signs of external corrosion. If any deterioration is observed then it is recommended that the frequency of inspection be increased.

3) Check the operation of the safety circuits if utilised.

9.3 4 Yearly

1) Remove the expansion vessel diaphragm as described in section 10.9 and inspect for wear/ageing. Inspect the internal surface of the vessel for corrosion.

Significant corrosion can lead to failure of the vessel; replacement of the entire vessel should be considered. If necessary replace the diaphragm as described in section 10.9.

10.0 SERVICING AND REPLACEMENT OF COMPONENTS

Note! When servicing or replacing components electrically isolate the unit and close the system and expansion vessel isolating valves. The unit should also be isolated from the pressure alarm circuits.

When remaking screwed connections use a thread sealant .

The cover on the unit is secured by one screw at the lower edge of the front panel only.

10.1 Hamworthy Heating Recommended Spares

Part	Part N°
Pump Assembly (Single Pump Unit)	530905053
Pump Assembly (Twin Pump Unit)	530905054
Pressure Sensor	532496003
Control Box Assembly (Wall Mount Unit)	563902272
Main Control PCB Single Pump Unit	533902063
Main Control PCB Twin Pump (Floor Standing Unit)	533902065
LCD Display PCB	533902064
Float Switch	531203006
Float Valve Assembly	531911038
Non-return valve cartridge	531911040

NOTE! For any service/replacement parts the unit serial No. (on the Data Plate inside the unit) **MUST** be quoted. For service or spares contacts please refer to the inside front cover of this guide.

10.2 Pump Removal (part n° 530905053 & 530905054)

- 1) Isolate unit from electrical & water supplies as well as connecting circuitry.
- 2) Isolate water by turning screw in ball valve see fig 18 below.
- 2) Disconnect the tube from the last grey elbow fitting using the blue tool provided. Take care to line up the tool correctly before pushing the tool into the fitting to release the pipe (see fig 19).
- 3) Disconnect the outlet pipe from the pump. Remove the quick release clip first (see fig 20)
- 4) Disconnect the wiring on the mains terminal (see fig A1)
- 5) The pump assembly including the mounting plate can now be removed from the unit.
- 6) When the pump assembly has been removed the pump can easily be removed from the assembly.



Figure 18

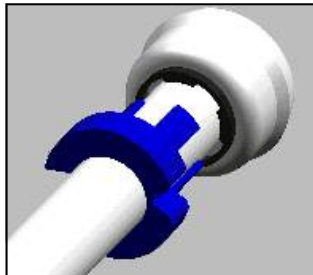

Figure 19



Figure 20

10.2.1 Pump Fitting

Pump fitting for each unit is basically the reverse of pump removal.

Care should be taken not to over tighten the 2 pump mounting screws as this can shear the welded thread. Once re-fitted and connected the pump needs to be bled. Instructions of this can be found in section 7.6.

10.3 Replacement Of Pressure Sensor (Part No.531911038)

The pressure sensor is assembled into the outlet pipe work from the pump.



Figure 21 - Pressure Sensor



Figure 22 - Location Of Sensor

- 1) Isolate the unit from the electrical, water supply & connecting circuitry.
- 2) Disconnect the beige cable socket from the sensor (Fig 21).
- 3) Unscrew the sensor from its soldered boss. (Fig 22)
- 4) Apply a small amount of WRAS approved sealant to the thread of the replacement sensor.
- 5) Screw the replacement sensor into the boss.

10.4 Replacement Of Control Box Assembly On Wall Mount Unit (Part No. 563902272)

To remove the control box assembled to the door of the unit.



Figure 23 - Control Box



Figure 24 - Controller Terminals

- 1) Ensure the unit has been isolated from the 230V / 50Hz mains supply & connecting circuitry.
- 2) Unscrew the screw at the base of the sheet metal front cover of the unit and lift off the cover from the unit.
- 3) Unscrew the 4 screws shown in figure 23 and remove the lid of the box.
- 4) Disconnect the terminal connections to the PCB.
- 3) Loosen the cable gland nuts of the box and withdraw the terminal ends of the cables through the glands.
- 4) Remove the M4 nuts behind the hinged door panel to unfix the control box to the door.
- 5) Replace the control box and secure to the door using the nuts.
- 6) Open the replacement box by removing the lid.
- 7) Loosen the cable gland nuts of the replacement box and feed the ends of the cables through the glands and connect the cables to the correct terminal of the PCB. Refer to the wiring diagram in Appendix A1.
- 8) Reassemble the lid of the box, reconnect the electrical supply to the unit and replace the sheet metal front cover on the unit.

10.5 Replacement Of Controls PCB (Part No 533902063 - Single pump PCB / 533902065 - Twin Pump PCB)

The main control PCB of the wall mount and floor standing units are enclosed in a plastic box at the same position on the hinged door of the unit. To replace the mains PCB :-

- 1) Ensure the unit has been isolated from the 230V / 50Hz mains supply & connecting circuitry.
- 2) Remove the front cover of the unit Remove the lid of the box.
- 3) Disconnect the wires to the terminals of the PCB.
- 4) Loosen the nuts securing the PCB to the stand offs in the box.
- 5) Locate the replacement PCB over the stand-offs and secure the PCB to the stand-offs by reassembling the nuts.
- 6) Reconnect the wires to the correct terminal of the PCB as defined in the wiring schematic of Appendix A1.
- 7) Reassemble the lid of the box and reconnect the power to the unit.

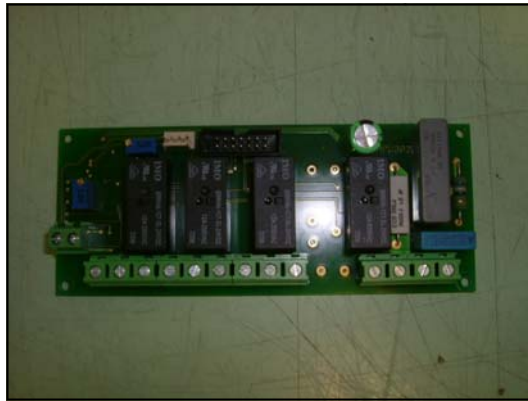

Figure 25 - Main Control PCB (Single Pump Unit)

10.6 Replacement Of Display PCB (Part No. 533902064) on Wall Mount Unit.

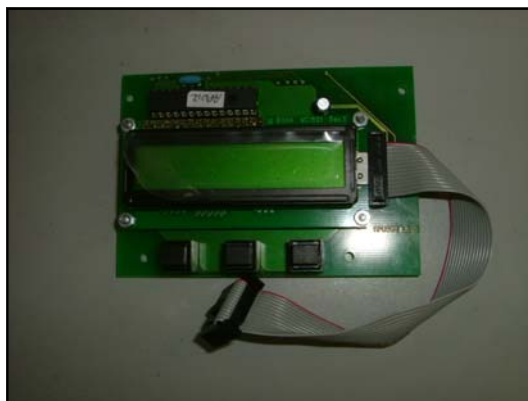

Figure 26 - Display PCB

- 1) Isolate the mains electrical supply.
- 2) Remove the sheet metal front cover as previously described.
- 3) Remove the lid of the plastic box.
- 4) Remove the ribbon cable plug of the from the main PCB.
- 5) Remove the nuts securing the display PCB to the stand-offs in the lid of the box.
- 6) Replace the display PCB to the stand offs in the lid and secure using the nuts.
- 7) Reconnect the new display PCB ribbon cable plug to the main PCB and reassemble the lid.
- 8) Replace and secure the sheet metal front cover & reconnect the electrical supply.

10.7 Replacement Of display PCB (Part No. 533902064) on Floor Mount Unit .

The display PCB is assembled to the rear side of the inclined panel of the Floor mounted unit see Figure 27.



Figure 27 - Display PCB Location Floor Standing Unit



Figure 28 - Removal Of Inclined Panel



Figure 29 - Enclosure Disassembly



Figure 30 - Assembly Of Display PCB In Enclosure

To replace :-

- 1) Isolate the unit from the mains electrical supply.
- 2) Remove securing screws found either side of the inclined top panel.
- 3) Lift panel off and lay flat on top of the sheet metal front cover.
- 4) Loosen screws securing the plastic box enclosing the display PCB to the inclined sheet metal panel .
- 5) Disconnect ribbon cable plug from Display PCB.
- 6) Unfasten screws securing the display PCB on the stand off's in the plastic box.
- 7) Remove the display PCB from the stand offs and replace the PCB.
- 8) Reassemble everything in reverse order making sure the seal is in place on the enclosure & reconnect the mains electrical supply to the unit.

10.8 Replacement Of Low Water Level Switch (Part No. 531203006)

The tank contains a water level switch for general alarm indication.

- 1) Isolate the unit from the mains water & electrical supplies.
- 2) Remove the screw securing the front cover and remove front cover.
- 3) Remove the lid from the main control box & disconnect terminals 1 & 2 on the control PCB.
- 4) Loosen the nut off the cable gland through which the cable of the level switch is fed to the control box.
- 5) Withdraw the terminalized end of the level switch cable through the cable gland and heat shrink tube.
- 6) Drain the supply tank of water. Refer to Figure 31.
- 7) Undo the nut on the outside of the tank securing the float switch to the tank and remove the defect float switch. Refer to Figure 32.
- 8) Replace the level switch and secure the bulkhead nut, ensuring the seal on the inside of the tank is correctly located and the float is operating correctly.

- 9) Feed the end of the level switch wire back through the heat shrink tubing, through the cable gland (& nut) & into the control box.
- 10) Reconnect the end of these wires to terminals 1& 2 of the main control board.
- 11) Tighten the cable gland nut and put the control box lid back on.
- 12) Reconnect the electrical supply to the unit. The unit should go into General Alarm mode.
- 13) Reconnect the mains water supply which should lift this alarm.
- 14) Lift the front cover back on & secure with screw.



Figure 31 - Level Switch In Tank



Figure 32 - Level Switch As Supplied

10.9 Inlet Valve (Part N° 531911038)

The inlet valve and float in the header tank are supplied as one assembly (see fig 14).

- 1) Isolate the unit from the water supply.
- 2) Undo 1/2" BSP connection to remove supply pipe.
- 3) Unscrew the lock nut from the inlet tube. The valve and float are now free to be removed.
- 4) On the standard unit there is a black spacer which fits between the tank and the chassis. This must be refitted when a new assembly is installed.
- 5) Once fitted the float adjustment should be set to the lowest level (see section 7.5)

10.10 Non-Return Valve (Part N° 531911040)

- 1) Follow the procedure for removal of the pump (see section 10.2).
The valve is inside the brass quick release fitting shown in figure 34.
- 2) Unscrew the brass fitting from pump.
- 3) Push the valve out from the brass fitting (see fig 33).



Figure 33 - Non Return Valve Assembly



Figure 34 - Non Return Valve Fitting Location On Pump

10.11 System Expansion Vessel Diaphragm

(Part N° dependant on model and serial N°. Consult Hamworthy Heating for details)

- 1) Turn off the boiler and electrically isolate the unit.
- 2) Close the system isolating valve and isolate the mains water supply to the header tank.
- 3) Drain the pressurisation unit and expansion vessel. **Note!** Leave the drain cock open. Disconnect the expansion vessel pipe-work.
- 4) Unscrew the diaphragm top connection (normally a brass nut at the opposite end to the water entry).
- 5) Remove the bolts from the flange at the base of the vessel and remove the diaphragm.
- 6) To replace the diaphragm top connection (normally a brass nut at the opposite end to the water entry).
- 7) Screw the plug lightly into the diaphragm top connection and pull it up through the expansion vessel.
- 8) Lockup the diaphragm top connection and tighten the water connection flange screws. Note! Ensure that the diaphragm is not twisted.
- 9) Reconnect the expansion vessel pipe-work.
- 10) To restart the system follow the steps in section 7.

APPENDIX

Contents	Page
Figure A1 Wiring Diagram	20
Figure A2 Heating System Calculation Sheet	22

Figure A2 - Heating System Calculation Sheet

1. System Parameters

System Water Content - $V_s =$ litres
 System Anti-freeze Content - $ra =$ %
 Maximum System Working Pressure - $P_w =$ bar
 Maximum Static Head - $P_h =$ metres

Example

$V_s = 2000$ litres
 $ra = 10\%$
 $P_w = 8$ bar
 $P_h = 22$ m

If the system volume is not known then the following rule of thumb can be applied:

$$\text{System water content} = \text{Boiler power (KW)} \times 10$$

2. Expansion Vessel Volume Calculation, V_v -

$$V_v = \frac{(ra + 81.5) \times V_s}{921} = \frac{(\text{} + 81.5) \times \text{}}{921} \quad V_v = \text{} \text{ litres}$$

$$V_v = \frac{(10+81.5) \times 2000}{921} = 199$$

If the system is to be set up using the factory preset alarm levels for the Chesil unit then no other calculations are necessary. The factory preset levels are:

Cold Fill Pressure Switching Level, $P_f = 1.8$ bar
 Hi Pressure Alarm Level, $P_{hi} = 3.6$ bar
 Lo Pressure Alarm Level, $P_{lo} = 1.3$ bar

The safety valve lift pressure should be set 0.35 bar above the Hi pressure alarm level.

3. Cold Fill Pressure Switch Setting Calculation, P_f -

$$P_f = \frac{P_h}{10.2} + 0.2 = \frac{\text{}}{10.2} + 0.2 \quad P_f = \text{} \text{ bar}$$

$$P_f = \frac{22}{10.2} + 0.2 = 2.35$$

4. Safety Valve Lift Pressure Calculation, P_s -

Actual fitted expansion vessel volume, V_{va} - litres
 Actual fitted expansion vessel acceptance factor, a_{va} -

$$a_{va} = \frac{V_v \times 0.35}{V_{va}} = \frac{\text{} \times 0.35}{\text{}} \quad a_{va} = \text{}$$

$$V_{va} = 300$$

$$a_{va} = 0.23$$

Actual working pressure, P_{wa} -

$$P_{wa} = \frac{P_f + a_{va}}{1 - a_{va}} = \frac{\text{} + \text{}}{1 - \text{}} \quad P_{wa} = \text{} \text{ bar}$$

$$P_{wa} = \frac{2.35 + 0.23}{1 - 0.23} = 3.35$$

Note! If $P_{wa} > P_w$ then increase expansion vessel volume, V_{va} and recalculate from step start of step 3

$$P_s = P_{wa} + 0.7 = \text{} + 0.7 \quad P_s = \text{} \text{ bar}$$

$$P_s = 3.35 + 0.7 = 4.05$$

5. Calculation of Expansion Vessel Acceptance Factor at Safety Valve Lift Pressure, a_s -

$$a_s = \frac{P_s - P_f}{P_s - 1} = \frac{\text{} - \text{}}{\text{} - 1} \quad a_s = \text{}$$

$$a_s = \frac{4.05 - 2.35}{4.05 - 1} = 0.56$$

Note! If $a_s > 0.5$ then increase expansion vessel volume, V_{va} and recalculate from step start of step 3

6. Lo Pressure Alarm Setting Calculation, P_{sl} -

$$P_{sl} = P_f - 0.3 = \text{} - 0.3 \quad P_{sl} = \text{} \text{ bar}$$

$$P_{sl} = 2.05$$

7. Hi Pressure Alarm Setting Calculation, P_{sh} -

$$P_{sh} = P_{wa} - 0.35 = \text{} - 0.35 \quad P_{sh} = \text{} \text{ bar}$$

$$P_{wa} = 3.0$$

NOTES

USEFUL USER INFORMATION

INSTALLER	SITE ADDRESS

Notes

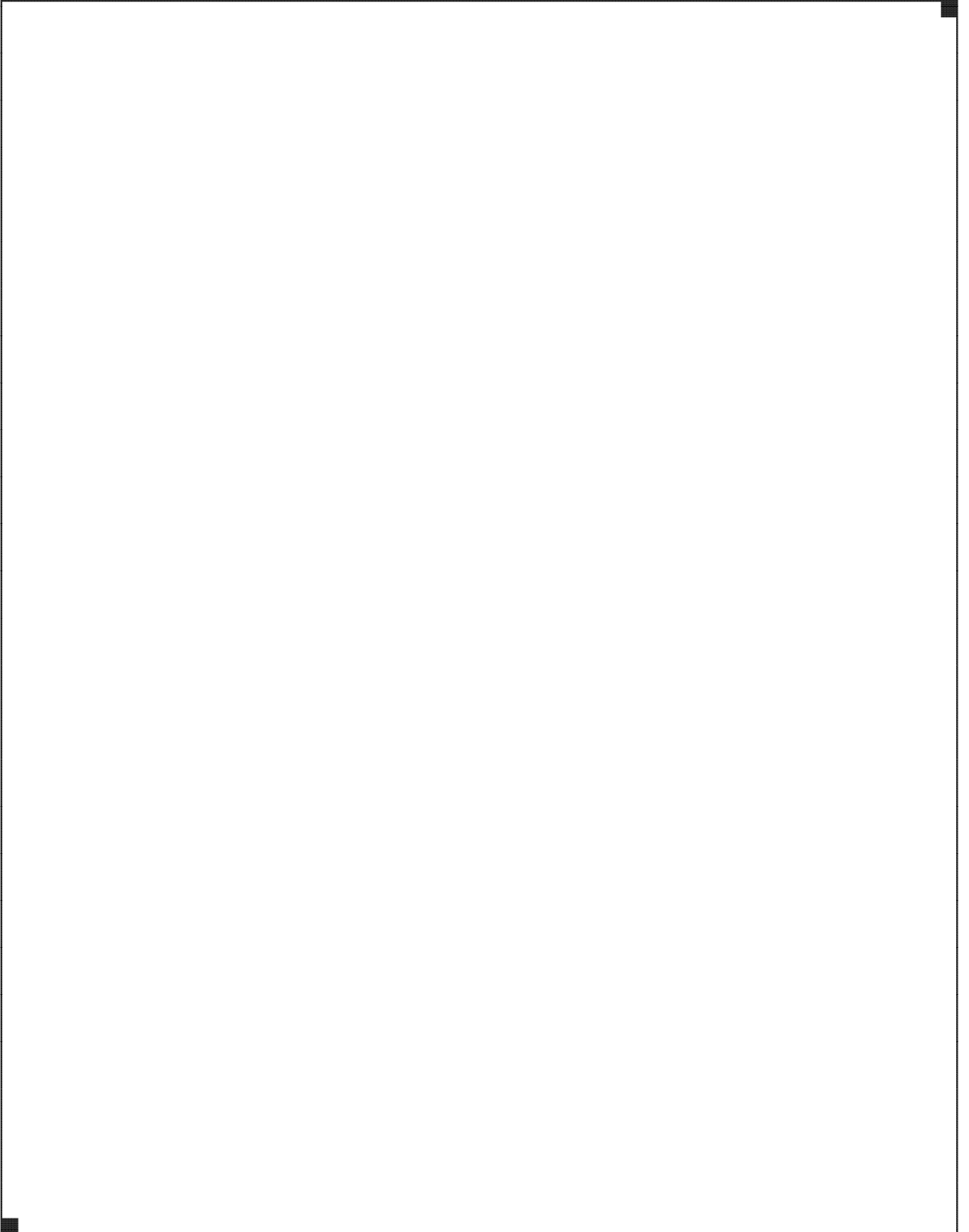

Hamworthy Heating Accredited Agents

North West England

Gillies Modular Services
210-218 New Chester Road, Birkenhead, Merseyside L41 9BG
tel: **0151 666 1030** fax: **0151 647 8101**

Southern Ireland

HEVAC Limited
Naas Road, Dublin 12, Ireland
tel: **00 353 141 91919** fax: **00 353 145 84806**

Northern Ireland

HVAC Supplies Limited
Unit A6, Dargan Court, Dargan Crescent, Belfast BT3 9JP
tel: **02890 777737** fax: **02890 771233**

Scotland

McDowall Modular Services
14-46 Lomond Street, Glasgow, Scotland G22 6JD
tel: **0141 336 8795** fax: **0141 336 8954**

North East England

Allison Heating Products
12 Sunnyside Lane, Cleadon Village, Sunderland SR6 7XB
tel: **0191 536 8833** fax: **0191 536 9933**



Customer Service Centre

Hamworthy Heating Limited,
Fleets Corner, Poole,
Dorset BH17 0HH.

Telephone: **0845 450 2866**

Fax: **01202 662522**

Email: **aftersales@hamworthy-heating.com**

Website: **www.hamworthy-heating.com**