



Authorised User No. 00510



# Hamworthy Fleet Wall Hung

Condensing Boilers  
Natural Gas  
Outputs 40kW to 150kW



Heating *at work.*

# Fleet

## Wall Hung Boilers

The Fleet range of commercial boilers has been designed by Hamworthy, using our extensive knowledge and experience to meet the needs of the UK heating market.

Built in Britain at our factory in Poole, the Fleet features our innovative cast aluminium alloy sectional heat exchanger which is rated to 6 bar operating pressure.

The wall hung range is available in 8 models, with outputs from 40kW to 150kW, delivering high efficiency condensing performance up to 109% nett efficiency.

The increased range of outputs enables systems to be designed using the optimum number of modules, being mindful of the life time costs associated with servicing heating plant.

Environmental credentials are reinforced by low NOx levels achieving European Class 5, and below the threshold for BREEM specifications.

The combustion system uses tried and tested pre-mix burner technology to ensure reliable performance throughout the life of the product, and the control system is the ultra reliable Siemens platform, which enables a comprehensive range of controls options to be offered.

Each boiler is equipped with its own integral pump, managing the flow through the boiler and removing the need for a primary circuit pump. Naturally, the Fleet range of wall hung boilers is available with convenient options to simplify and reduce the cost of installation, including pipework kits and a choice of flue systems, including open flue or room sealed, with concentric or twin duct options.

## Options

- **Pipework header kits with frame-set**
- **Low loss headers**
- **Choice of flue systems**
- **Flue header kits**
- **Single or multiple boiler controls**

- **Close load matching**
- **Excellent condensing performance**
- **Complete versatility in applications**
- **Comprehensive flue options**
- **Factory tested pipe kits**
- **Extensive controls capability**

BENEFITS

**The Fleet range of modular boilers features a robust commercial heat exchanger which achieves complete versatility through its sectional design.**



*Fleet wall hung boiler with frame-set and pipe kit*

# Fleet

## Condensing Boilers

Wall hung boilers are often favoured for convenience of use. Being smaller than traditional boilers, they're easier to handle, and can be installed side-by-side in modular boiler arrangements very neatly. If the wall construction doesn't support the weight, then steel floor standing frames can be used, with the added advantage of factory built and tested pipe kits.

Fully modulating pre-mix burners ensure building loads are accurately matched, and with optional boiler sequence controls, the optimum number of boilers to meet demand is always guaranteed.

Built in Hamworthy's Poole factory, high quality construction and reliability is assured, with every boiler passing a pre-delivery audit including full wet fire testing. Each boiler is delivered fully assembled within a robust steel casing with a pair of doors for easy access, and finished in two-tone white and grey powder coat.

Factory assembled frame sets with pipework header systems facilitate fast installation with the reassurance that pipework is sized to ensure water volume is matched to the boiler operating performance.

Fleet boilers are fitted with comprehensive controls using the Siemens platform, ensuring safe and reliable performance.

A wide range of controls options, including wired or wireless sensors, make the Fleet a highly versatile package. The optional Merley sequence controller complements the solution for modular boilers, for either stand alone or building management system (BMS) control.

A simple but comprehensive flue package completes the offer, to ensure that Fleet boilers can be installed in plant room locations from basement to rooftop and anywhere in between.

Flue systems are very versatile with a choice of open flue or room sealed with concentric or twin duct.

Concentric flues systems are capable of runs up to 60m in length whilst twin duct room sealed configurations can achieve up to 100m, depending on model selection.

For open flue applications with multiple boiler header systems, flues runs up to 150m are possible. *Refer to pages 22 to 31 for further details of flue systems.*

### Sectional Heat Exchanger

Used throughout our Fleet range of wall hung and floor standing modular boilers, the unique design of Hamworthy's heat exchanger enables our lean manufacturing plant to manufacture boilers easily and quickly to meet fluctuating demand for each output. With just three casting sections, front, rear and intermediate, heat exchangers can be built from stock to deliver outputs from 40kW to 150kW in the Fleet wall hung range, and in module sizes up to 350kW in the floor standing range.

The high quality aluminium alloy has better thermal conductivity than stainless steel, and combined with the strength and durability of our pressure die cast aluminium heat exchanger technology, delivers exceptional operating performance with ultra clean emissions and a long service life.



*Fleet sectional heat exchanger.*

### Heat Exchanger 5 Year Warranty

Fleet condensing boilers are supplied with our extended five year warranty on the heat exchanger as standard. As with any aluminium alloy heat exchanger, it is important that approved water treatment is maintained throughout the life of the boiler.

All other components carry a standard two year warranty on parts.

Where the product is commissioned by Hamworthy Service Engineers, then the warranty also covers labour for the warranty period, subject to servicing and warranty conditions.

### Boiler Output Selection Chart

	No. of Boilers			
	1	2	3	4
Outputs (kW)	40	80	120	160
	50	100	150	200
	60	120	180	240
	70	140	210	280
	85	170	255	340
	100	200	300	400
	125	250	375	500
	150	300	450	600

# Specification

## Fleet Wall Hung Boilers

### Heat Exchanger Quality Assurance

Specifically designed for the Fleet boiler range, the all new sectional cast silicon aluminium alloy heat exchanger delivers rapid thermal response with robust construction, assuring a long service life.

Manufactured using high pressure die casting to provide maximum strength, the process allows intricate mouldings and adherence to close manufacturing tolerances, ensuring precise fin detail for exceptional performance and reliability.

Silicon aluminium alloy has excellent pouring properties resulting in consistently high quality castings combined with excellent corrosion resistance.

Casting sections are first pressure tested individually at the foundry and then once again as a heat exchanger assembly in our factory, to 1½ times the maximum operating pressure, assuring water tight heat exchangers capable of continuous operation up to 6 bar working pressure.

### Condensate Management

Due to the high thermal efficiency of all modern boilers, condensation will occur within the boiler during firing from cold start-up, under low load conditions and on condensing boilers when the return temperature falls below the flue gas dew point of 55°C. Typically a 100kW condensing boiler will generate around 13 litres of condensate per hour in condensing conditions.

The condensate is typically 3.5pH, so slightly acidic but less so than vinegar, and can be disposed of normally through the drainage system. If in any doubt about local regulations, check with the local water authority. *For further details of the condensate drainage requirements, please refer to page 17.*

The Fleet wall hung boiler heat exchanger is equipped with an injection moulded polypropylene sump which connects to the flue system. Condensate is drained safely via a water trap to a connection for the drainage system. The condensate drain is a generous size (32mm diameter) to ensure easy flow of condensate, and the boiler includes a safety interlock to indicate any flue or condensate blockage, protecting the boiler from potential damage.

### Burner

A cylindrical fully modulating pre-mix burner is positioned centrally within the heat exchanger and is constructed using a FeCrAl Aconit woven mesh. This design of burner provides excellent flame stability across the full range of modulation from 20% to 100%. Utilising a spark ignition system, the burner is lit directly, and flame proving is achieved by means of a flame rectification probe.

### Gas Train

Gas and air are precisely mixed before entering the burner using a zero governor gas valve arrangement. This is achieved by measuring the pressure drop across a venturi at the fan inlet and adjusting the gas pressure accordingly.

### Low Emissions

All Fleet boilers achieve European Class 5 performance for NOx emissions. The woven fibre construction of the burner delivers consistent gas distribution with resultant low flame temperatures and NOx emissions as low as 35 mg/kWh.

### Efficiency

Fleet condensing boilers achieve a full load efficiency up to 88% gross (98% nett), whilst at part load the efficiency rises to 98% gross (109% nett). This equates to seasonal efficiencies up to 96.5% gross, far exceeding the Building Regulations minimum seasonal efficiency requirements of 86% gross for new buildings and 82% gross for existing buildings, using natural gas.

### Safety Relief Valve

Each boiler is equipped with an individual 7 bar safety pressure relief valve with discharge pipe.

### Flue Gas Temperature Protection

Whilst the operating flue gas temperature is very low, ~65°C at 80°C flow temperature, the flue system is further protected with a flue gas temperature sensor that prevents firing of the boiler should the flue gas temperature exceed 85°C.

### Flue System Condensate Discharge

In addition to the boiler condensate drainage, it is important that the flue system is drained independently, to avoid flue condensate running back through the boiler. This is particularly important where mixed materials are used in the flue system, such as aluminium and stainless steel.

*Please refer to the flue section on pages 22 to 31 for further details.*

### Delivery

Fleet wall hung boilers are delivered to site fully assembled and palletised in the upright position, within a protective cardboard outer sleeve. The palletised design allows the boiler to be located to the wall bracket using lifting equipment, and once in position the pallet can be removed exposing the system connections for installation.

### Building Regulations 2010 - Part L

All Fleet boilers comply with the requirements of Building Regulations 2010 Part L, easily exceeding the minimum seasonal efficiency requirements for new and existing buildings as defined in Approved Documents L2A – Conservation of fuel and power in new buildings other than dwellings, and L2B – Conservation of fuel and power in existing buildings other than dwellings.

Fleet seasonal efficiency data is shown in the table on page 8.

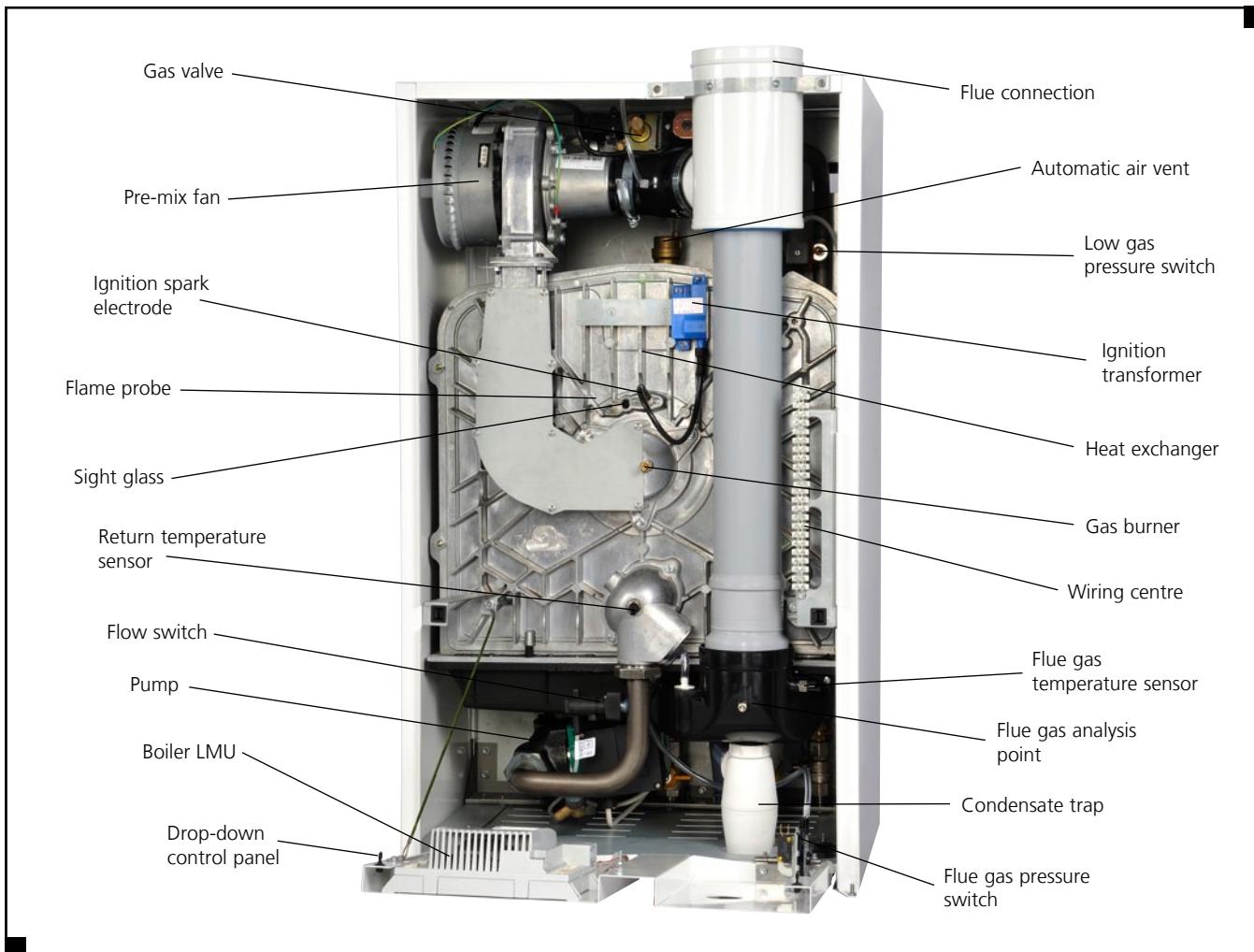

Fleet wall hung boiler

### Layout

The Fleet range of wall hung boilers can be installed as either single units or as part of a modular arrangement. Up to four boilers can be connected using prefabricated frame-sets complete with pipework kits which run below the boilers. The use of pre-fabricated pipework can greatly reduce on site installation time. All headers are supplied fully assembled and factory tested, complete with the necessary interconnecting fittings and valves. *Refer to page 7 for further details.*

### Flue Terminal Location

All condensing boilers will produce condensate due to their high thermal efficiency. One effect of this condensate production is to produce plumbing from the flue terminal, and careful consideration must be given to the location of the flue terminal. Should plumbing be a concern, then the flue system should be designed to discharge at high level so as not to cause a visual intrusion to the building occupants.

### Integral Pump

Each boiler is fitted with an integral pump ensuring the correct flow rate is achieved. The pump is started on each firing cycle and equipped with five minute pump overrun to remove residual heat, plus a periodic-kick feature to reduce the risk of pump seizure.

The pump is matched to provide 20°C  $\Delta t$  temperature differential across the boiler.

Using an integral pump with each boiler also removes the need for a dedicated primary circuit pump, and reduces standby losses to an absolute minimum. Pump operation flow protection is provided via a flow switch in the water return of each boiler, ensuring the boiler cannot fire when there is insufficient flow, (or no water content) protecting the boiler from potential damage.

# Controls Overview

## Fleet Wall Hung Boilers

### Boiler Controls

Fleet boilers can be installed in a wide variety of configurations, from single boiler applications to multiple boilers controlled locally or by a building management system. Each boiler features an extremely versatile microprocessor based boiler control system that can be tailored to meet the exact needs of the heating system, and capable of integrating the boiler and other system components.

Every Fleet boiler is equipped with the following control features as standard:

- LPB Bus communication input/output
- Remote on/off control input
- Remote modulation input
- External air temperature sensor input
- Remote interlock signal input
- Volt free contacts
- Frost protection



Clip in modules on the LMU

### Temperature Control

All Fleet boilers are fitted with a manual reset limit thermostat set to 100°C.

An electronic temperature control thermostat regulates the boiler flow temperature up to a maximum of 90°C.

Fleet boilers also incorporate a return temperature sensor, which in conjunction with the flow temperature sensor governs the modulation set point of the boiler.

### Volt Free Contacts

All Fleet boilers are fitted with a multi-function clip-in module to provide volt free contacts as standard.

Remote alarm signalling is provided for a general fault alarm and boiler normal run indication.

### 0-10 Volt DC Analog Input

The standard multi-function clip-in module also provides a 0-10 volt DC analog signal interface to control the modulation level of the burner, or to set the flow temperature set point. The 0-10 volt signal can be used for remote connection of the boilers to a Building Management System, (BMS) to enable modulating control remotely.

### LPB Bus Communications Module

The optional LPB bus communication clip-in kit is used to connect the boiler LMU control unit to the optional sequence control module. Each boiler in a modular installation requires a clip-in LPB bus communications module to communicate with the boiler sequence controller.

### External Air Temperature Sensor

Fleet boilers can be supplied with an optional external air temperature sensor to exploit the full functionality of the boiler controls, and enable direct temperature compensation on the boiler, maximising the opportunity for condensing operation.

When fitted with an external temperature sensor, the boiler's own thermostat is overridden and the flow temperature is controlled as a function of external temperature conditions.

Using a range of adjustable compensation slopes built into the standard boiler controls, the flow temperature profile can be tailored to suit the needs of individual heating systems.

For multiple boilers, the external temperature sensor should be used in conjunction with the optional Merley boiler sequence controller.

### Frost Protection

When fitted with an external air temperature sensor the boiler control system features a two stage frost protection system.

Stage one involves turning the integral boiler pump on should the external air temperature fall below 1.5°C. Stage two involves firing the boiler should the internal water temperature fall below 5°C. Whenever the boiler fires the internal pump is automatically switched on.

*For further details of controls for single boilers refer to page 12 and for multiple boilers, please see page 13.*

# Pipe Kits & Flues

## Fleet Wall Hung Boilers

The Fleet range of wall hung boilers can be fixed to suitable walls using the mounting plate supplied, or alternatively an optional range of floor standing steel fabricated frame-sets is available to support the boiler, complete with pipework headers and ancillary fittings.

Factory assembled frame-sets with pipework header systems facilitate fast installation with the reassurance that pipework is sized to ensure water volume is matched to the boiler operating performance.

Each Fleet boiler has an internal pump, which removes the need for a dedicated primary circuit pump.

### Fast-fit Frame-sets & Pipework Kits

Making multiple boiler installation easier, the frame-sets support the pipework and eliminate any misalignment that may be present in the building structure, reducing installation time.

The pipework includes headers for water flow and return, gas supply and condensate. Individual spill pipes are provided for discharging safety valves to floor level.

Final boiler connections to the pipework for flow, return and gas are completed using short stainless steel flexible connectors and quarter-turn ball isolating valves.

Frame-sets are designed for installation against a wall and available for either one or two boilers. Two frame-sets can be joined together to suit applications with three or four boilers.

The frame-sets can be freestanding, but must be fixed securely to the floor for improved stability.

### Low loss header

To complement the frame-sets and pipework kits, a choice of low loss header is available with either a pair of connections for a single secondary circuit, or three pairs of connections for up to three secondary circuits. The low loss headers are sized specifically to suit up to 600kW maximum boiler capacity, and when used in conjunction with a pipework kit, ensures there is sufficient water volume in the primary circuit to operate the boilers safely.

### Individual Flues or Header Systems

Flexible flue arrangements allow Fleet boilers to be flued either individually, or in a multiple boiler arrangement with common flue header.

All flue systems are manufactured in polypropylene, with EPDM lip seal to create a pressure tight installation.

Flue solutions include both room sealed and open flue configurations. Room sealed flues are available with concentric horizontal or vertical arrangements, or twin duct systems. Open flue systems are available for both horizontal and vertical termination.

### Room Sealed Flue Systems

The room sealed flue options for Fleet boilers offer great flexibility in the design, location and routing of the flue system. The flue components have been matched and tested specifically for use with these boilers. This ensures optimum performance from the installation and simplifies the necessary sizing calculations.

Concentric flue systems type C13  
- Horizontal termination

Concentric flue systems type C33  
- Vertical termination

Twin duct flue systems type C53  
- Horizontal flue termination  
- Horizontal air inlet

Twin duct flue systems type C53  
- Vertical flue termination  
- Horizontal air inlet

### Conventional Open Flue Systems

The Fleet is also suitable for connection to an open flue system. Open flue applications can utilise the same flue components as the twin duct room sealed system.

Open flue systems type B23  
- Horizontal termination

Open flue systems type B23  
- Vertical termination

### Flue Header Systems

Alternatively for systems where multiple boilers are installed, a modular header can be used in conjunction with a common chimney.

Open flue systems type B23  
- Offtake to header system

Open flue systems type B23  
- Flue header systems

*For further details of flue systems available with the Fleet range of wall hung boilers, refer to pages 22 to 31.*

# Technical Data

## Fleet Wall Hung Boilers

	Boiler Model	F40W	F50W	F60W	F70W	F85W	F100W	F125W	F150W	
Energy	Building Regulations seasonal efficiency gross (%)	97.4	97.4	95.5	95.5	95.5	95.5	95.5	97.4	
	Boiler output 50/30°C	kW Btu/h x 1000	40 136	50 171	60 205	70 239	85 290	100 341	125 427	150 512
	Boiler output 80/60°C	kW Btu/h x 1000	36.1 123	45.1 154	54.1 185	63.2 216	76.7 262	90.3 308	112.8 385	135.4 462
	Boiler input (gross) Maximum	kW Btu/h x 1000	41.0 140	51.3 175	61.5 210	71.8 245	87.2 298	102.6 350	128.2 437	153.8 525
	Boiler input (nett) Maximum	kW Btu/h x 1000	36.9 126	46.2 158	55.4 189	64.7 221	78.5 268	92.4 315	115.5 394	138.6 473
	Boiler output Minimum 80/60°C	kW Btu/h x 1000	7.2 25	9.0 31	10.8 37	12.6 43	15.3 52	17.9 61	21.6 74	26.9 92
Water	Water content (not including headers)	litres	4	4	5	5	6	6	7	8
	Design flow rate @ 20°C Δt rise	l/s	0.48	0.6	0.72	0.84	1.02	1.19	1.49	1.79
	Residual pump head @ 20°C Δt rise	kPa m	2.7 0.27	2.0 0.20	1.4 0.14	0.6 0.06	4.2 0.42	3.4 0.34	2.2 0.22	3.0 0.30
	Maximum water pressure	barg	6.0							
Gas	Gas flow rate natural gas (G20) – Maximum	m³/h	3.9	4.8	5.8	6.8	8.25	9.7	11.7	14.6
	Nominal gas inlet pressure natural gas (G20)	mbar	20							
	Maximum gas inlet pressure natural gas (G20)	mbar	25							
Flue	Approx. Flue gas volume @ 15°C, 9.1% CO <sub>2</sub> , N.T.P	m³/h	60	75	90	105	120	150	187	225
	Maximum flue gas temperature	°C	65							
	NOx Emission (DAF) European Class 5	mg/kWh	35	35	36	36	37	37	38	39
	Pressure at flue outlet	Pa mbar	150 1.5							
Connection	Water flow/return connections		Rp1"						Rp1¼"	
	Gas inlet connection		R¾"						R1"	
	Nominal flue diameter (I/D)	mm	80						100	
	Safety valve (pipe tail)	mm	22							
	Condensate trap connection(s) (O/D)	mm	32							
Electrics	Power consumption – maximum	W	160	160	160	160	350	450	350	600
	Nominal supply voltage		230V 1Ph 50Hz							
	Module current	Start Amps Run Amps	0.85 0.35				2.1 1.0			2.4 1.2
	Approx. shipping weight	kg	75		90		105		120	130
	Noise emission @ 1m	Max dB (A)	56	58	52	54	58	61	63	68

# Dimensional Details

## Fleet Wall Hung Boilers

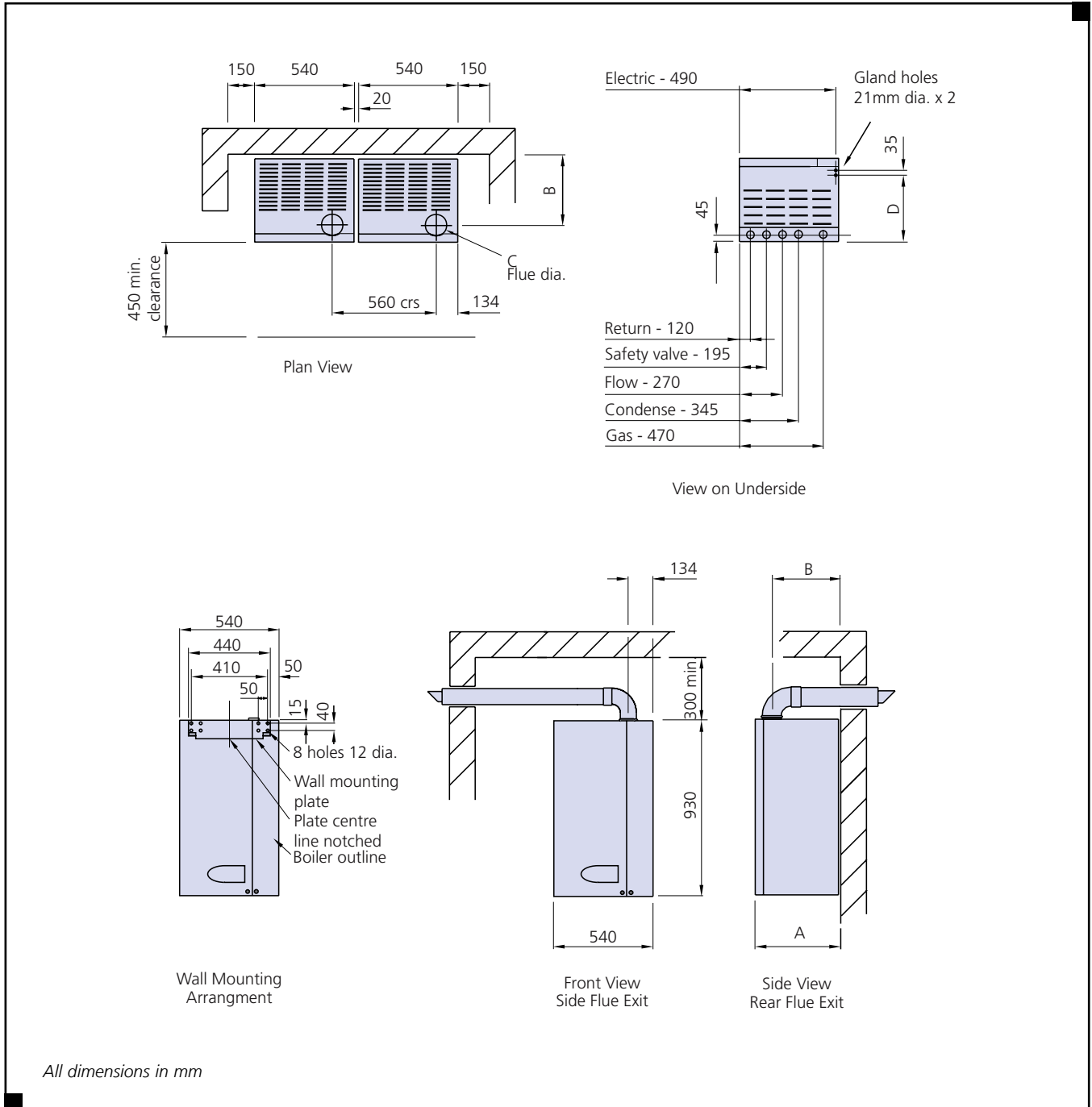

Model	Dimension	F40W	F50W	F60W	F70W	F85W	F100W	F125W	F150W
Casing depth	A				470				570
Flue depth	B				380				480
Flue diameter	C				80/125				100/150
Electrical connections	D				350				450

# Dimensional Details

## Fleet Wall Hung Boiler Pipe Kits & Flue Headers

### Single boiler arrangement

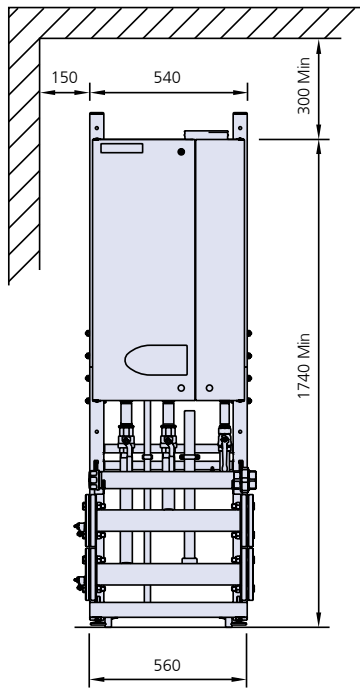

### Low Loss headers

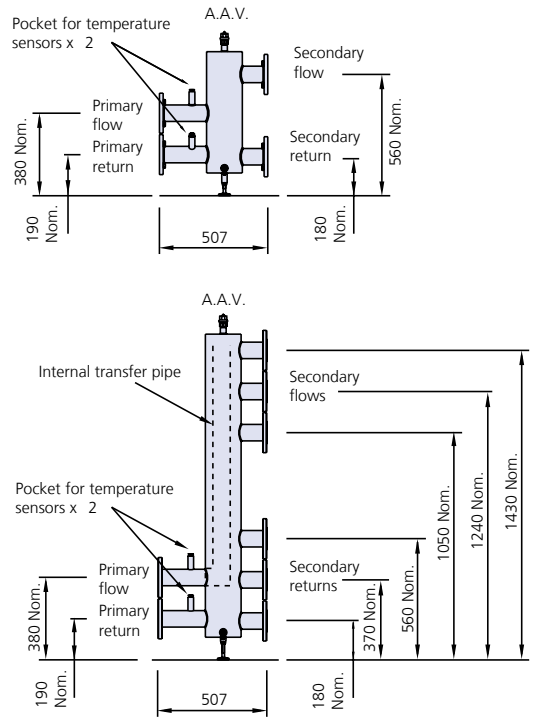

### Two boiler arrangement

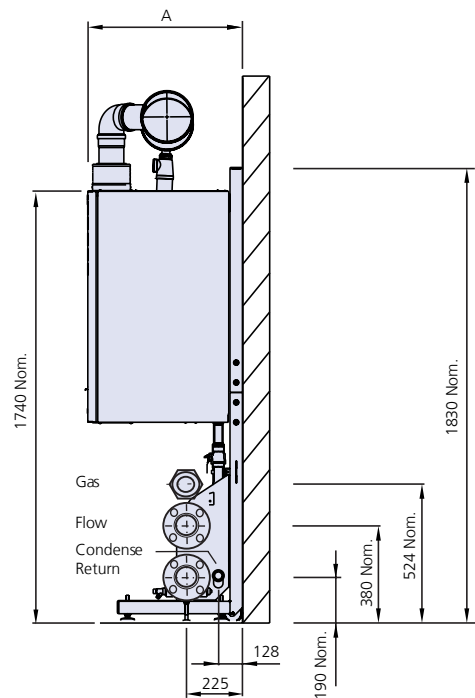
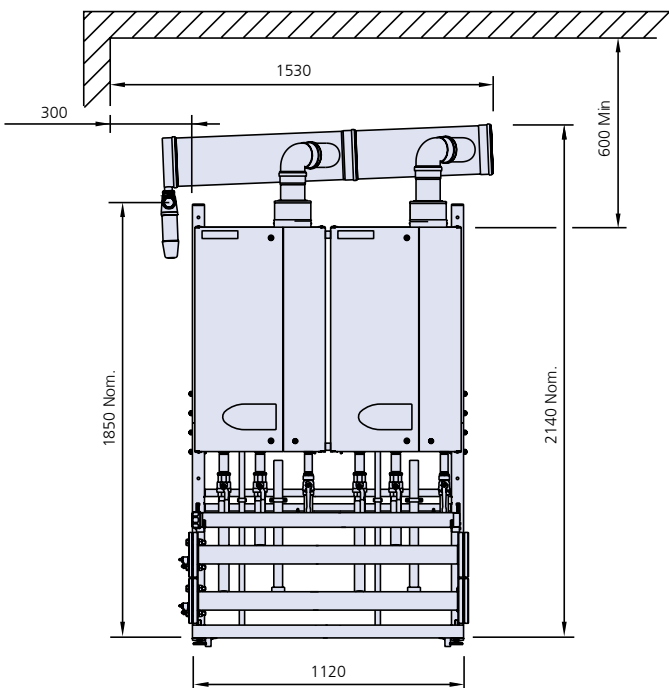

# Dimensional Details

## Fleet Wall Hung Boiler Pipe Kits & Flue Headers

### Pipe kit and low loss header connection sizes

For boilers F40W to F100W	
Flow	DN50 – PN16
Return	DN50 – PN16
Gas	R1½"
Condense	40mm

For boilers F125W to F150W	
Flow	DN65 – PN16
Return	DN65 – PN16
Gas	R2"
Condense	40mm

### Boiler dimensions

Model	Dimension A
F40W to F100W	470
F125W to F150W	570

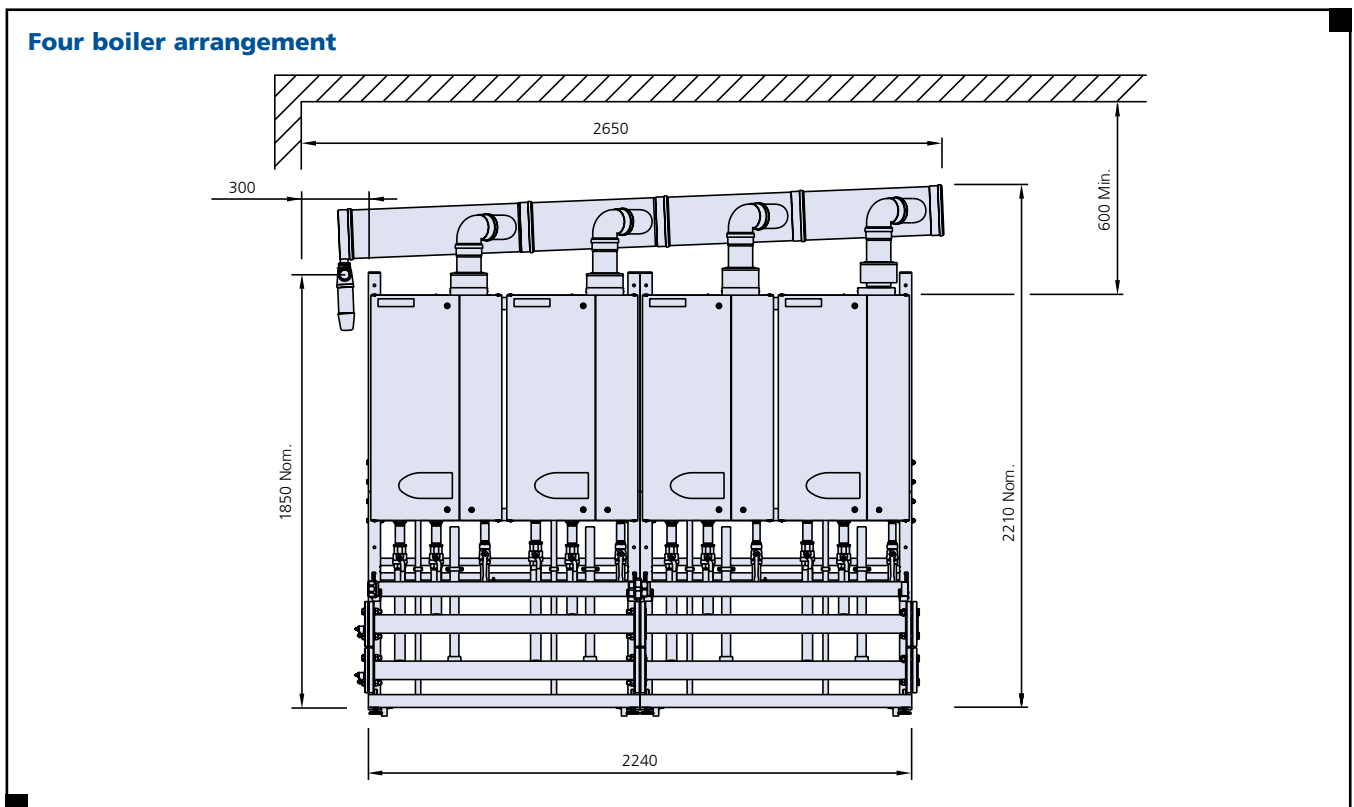
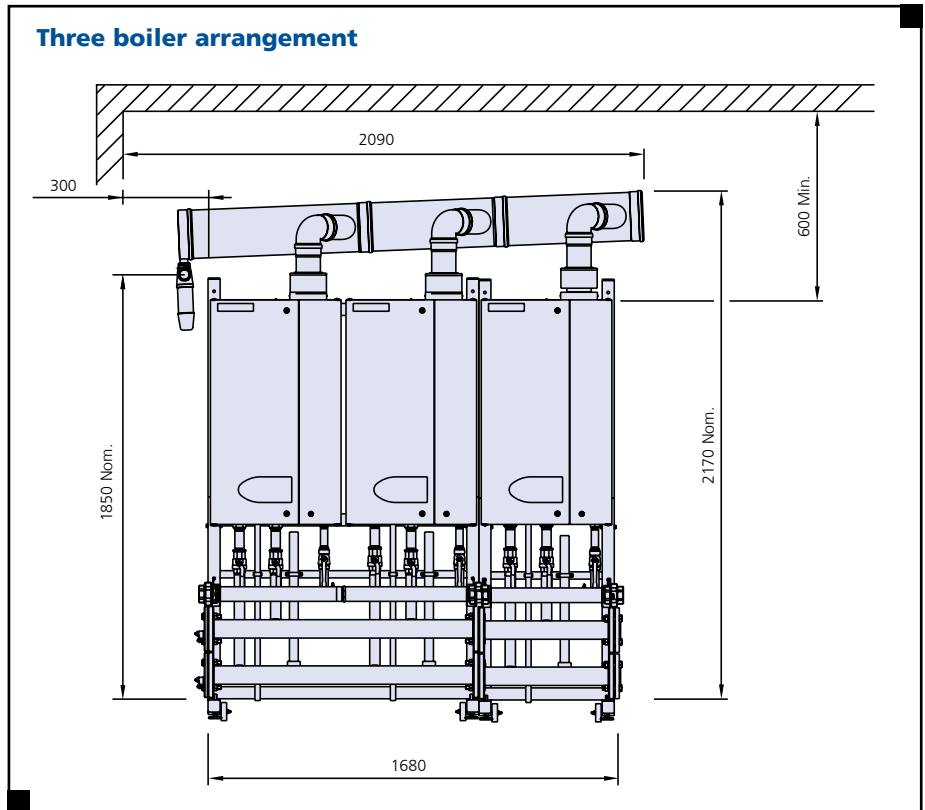

# Control Details

## Fleet Wall Hung - Single Boilers

The control options for single Fleet wall hung boilers are different to those for multiple boilers. *Please refer to page 13 for controls on multiple boilers.*

All controls functions are managed via the 'boiler management unit' Siemens LMU64. Using a combination of options, the level of control is expandable for up to 2 heating circuits and 1 domestic hot water cylinder.

A circulation pump overrun timer is incorporated within the boiler LMU.

### Programmable Room Sensor

A Fleet single boiler system can be fitted with a single programmable room sensor, which should be located in the first heating zone. This room thermostat allows heating circuit management to be based on both the internal and external air temperature. The boiler will manage the heating circuit pump via a contactor according to the program requirements of the programmable room unit.

Features:

- Individual 7 day program with auto summer / winter hour change for heating circuit 1, heating circuit 2 and DHW
- 3 periods per day per time program
- Constant or variable temperature flow
- Compensated flow temperature based on external and room air temperatures
- Optimised start / stop based on external and room air temperatures
- Building frost protection based on room air temperature
- Summer shutdown based on external air temperature
- Holiday period with frost protection
- Reduced temperature, night set back for non occupancy hours
- Pump kick for pumps controlled from boiler
- Programme lock to prevent tampering
- Individual temperature settings for each zone

To achieve full functionality an external air sensor must be fitted.

## Options for a Single Boiler only

- **Programmable room sensor**
- **External air sensor**
- **2nd Heating Circuit Clip-in Relay Kit**
- **DHW Cylinder Sensor Kit**

### External Air Sensor

An optional external air temperature sensor may be wired directly to the boiler to exploit the direct weather compensation functionality of the boiler controls. This sensor may be connected to the control scheme and should ideally be positioned on an external wall with northerly aspect.

### 2nd Heating Circuit Clip-in Relay Kit

To control a second heating circuit, an additional clip-in relay kit is required for fitting directly to the LMU. The kit comprises a relay and water temperature sensor complete with pocket.

This kit provides outputs for a pump and mixing valve.

- Mixing valve allows second heating circuit to operate at a different temperature set-point to heating circuit 1.
- Second heating circuit should operate at the same or lower temperature than circuit 1, e.g. underfloor heating.
- Programmed via the programmable room sensor
- Compensated flow based on external air temp and using a curve separate to that of heating circuit 1 owing to mixing valve
- Optimised start/stop based on external air temperature
- Frost protection based on water temperature in second heating circuit

For the second heating circuit, the boiler will manage the circuit pump and/or mixing valve via contactors, according to the program requirements of the programmable room sensor and the water temperature sensor.

Only one programmable room sensor may be connected, therefore the second heating circuit management is derived from time control and external air temperature measurement.

### DHW Cylinder Sensor Kit

This kit is for a domestic hot water (DHW) circuit directly controlled from the boiler, but programmed via the programmable room sensor, and features:

- Immersion sensor complete with pocket
- DHW cylinder sensor and pump output directly from boiler LMU
- Frost protection based on stored water temperature
- Reduced storage temperature for non-occupancy hours
- Anti-Legionella function

For the DHW cylinder circuit, the boiler will manage the primary coil pump according to the program requirements of the programmable room unit and the DHW cylinder sensor.

# Control Details

## Fleet Wall Hung - Multiple Boilers

The control options for multiple Fleet wall hung boilers are different to those for single boilers. *Please refer to page 12 for controls on single boilers.*

### Sequence Controller LPB Bus

For use with multiple boilers, the optional Merley sequence controller can control up to 16 boilers. Communication between the boilers and sequence controller is facilitated via the LPB bus.

Merley is the latest generation boiler sequence controller for multiple boiler installations. Using the Siemens controls platform, Hamworthy boilers can be controlled to share the load between boiler modules to maximise efficiency and system performance.



*Merley wall mounted sequence controller*

As a standalone device with autonomous control of the boilers, the controller can be extended to sequence control the boilers and also to manage a complete heating circuit as well as a domestic hot water (DHW) cylinder.

A range of room and external air temperature sensors, including wireless options, ensures comfort levels within the building are maintained.

When integrated with a building management system (BMS), the Merley operates only as a boiler sequence controller, receiving the required operating temperature from the building management system via a 0 to 10 volt analog signal.

Each sequence control system is supplied with a smart digital interface display allowing the user to monitor the current operating status of the boilers, and also the building where the Merley is used to control a heating zone and hot water cylinder.

*Full details of the Merley sequence controller are provided in publication, 500002524, available to download at [www.hamworthy-heating.com](http://www.hamworthy-heating.com) or request a printed copy, Tel: 0845 450 2865*

## Options for Multiple Boilers only

- **Boiler sequencing cascade controller**
- **LPB bus communications Clip-in module**
- **Choice of room sensors**
- **External air sensor**
- **Hard wired or wireless controls**
- **DHW Cylinder Sensor Kit**

The Merley boiler sequence controller can be supplied within a dedicated housing for wall mounting or as a loose kit for integrating within a plant room control panel.

### Wall Mounted Controller

Merley sequence controllers are available factory assembled within a robust steel enclosure suitable for wall mounting, with the digital interface display pre-mounted to the housing door.

The sequence controller is mounted to a DIN rail attached to the panel back plate assembly, with electrical trunking to simplify routing for site cables to the appropriate wiring terminations.

A cable gland plate is located on the underside of the control panel with 6 loose cable glands supplied for fitting on site.

### Loose Kit Controller

For installations where the sequence controller will be integrated within an existing or new plant room control panel, the Merley sequence controller can be supplied in loose kit form.

A suitable space must be allocated within the plant room control panel for mounting the sequence controller to the back plate and for mounting the digital display to the control panel door.

### Boiler Sequence Control Strategies

The Merley sequence controller can be configured to sequence boilers in traditional cascade mode or in unison mode.

#### Cascade Control

Steps a boiler module on at its lowest rate and then modulates it to its maximum rate, before switching on the next boiler module to match the system load. Maintains the lowest number of boiler modules in operation for a given heat load.

This control strategy is particularly suited to boilers operating in constant temperature systems where there is no great efficiency advantage to be gained from operating boilers at part load.

#### Unison Control

Steps each boiler module on in turn at its lowest rate, and then modulates all boiler modules simultaneously to higher rates to match the system load. This method of sequencing can offer higher operating efficiencies, taking advantage of the higher part load efficiencies available at low firing rates.

This control strategy is particularly suited to condensing boilers operating in variable temperature systems where low water temperatures and part load boiler operation allows optimum boiler operating efficiency to be achieved.

# Application & System Data

## Fleet Wall Hung Boilers

The installation of the boiler MUST be in accordance with the relevant requirements of the Gas Safety Regulations, Building Regulations, IEE Regulations and the Water Supply (Water Fittings) Regulations. It should also be in accordance with any relevant requirements of the local gas region and local authority and the relevant recommendations of the following documents :

These British Standard Codes of Practice and additional publications have relevant recommendations regarding the installation of Fleet boilers.

### British Standards

**BS 5440** Part 1 Flueing and ventilation for gas appliances of rated input not exceeding 70kW nett. Installation of gas appliances to chimneys and for maintenance of chimneys.

**BS 5440** Part 2 Flueing and ventilation for gas appliances of rated input not exceeding 70kW nett. Installation and maintenance of ventilation provision for gas appliances.

**BS 6798** Installation and maintenance of gas-fired boilers of rated input not exceeding 70kW nett.

**BS 6644** Installation of gas-fired hot water boilers of rated inputs of between 70kW nett and 1.8MW nett.

**BS 6700** Design, installation, testing and maintenance of services supplying water for domestic use.

**BS EN 806-2** Specification for installations inside buildings conveying water for human consumption – Part 2: Design

**BS 6891** Installation of low pressure gas pipework of up to 35mm (R1 ¼) in domestic premises.

**BS 6880** Part 1,2 & 3 Code of practice for low temperature hot water heating systems of output greater than 45kW

**BS 7074** Application, selection and installation of expansion vessels and ancillary equipment for sealed water systems. Part 2 Code of practice for low and medium temperature hot water heating systems.

**BS 7671** Requirements for electrical installations. IEE Wiring Regulations. Seventeenth edition.

### I. Gas E. Publications

**IGE/UP/1** Strength testing, tightness testing and direct purging of industrial and commercial gas installations.

**IGE/UP/1A** Strength testing, tightness testing and direct purging of small low pressure industrial and commercial natural gas installations.

**IGE/UP/2** Installation pipework on industrial and commercial premises.

**IGE/UP/10** Installation of flued gas appliances in industrial and commercial premises.

### Health and Safety Executive

Guidance note PM5 - Automatically controlled steam and hot water boilers.

### CIBSE Publications

**CIBSE Guide B** Heating, ventilating, air conditioning and refrigeration.

**CIBSE Guide H** Building Control Systems

**CIBSE Guide Energy Efficiency in Buildings**

**CIBSE Commissioning Code B: 2002**

### Third edition of the 1956 Clean Air Act Memorandum

Department of the Environment, Scottish Development Department & Welsh Office.

### Location

The location chosen for the boiler must permit the provision of a satisfactory flue system and an adequate air supply. The location must also provide adequate space for servicing and air circulation around each unit. This includes any electrical trunking laid along the floor and to the appliance.

The boiler can be mounted directly onto a wall or supported on a floor via a frame (Hamworthy can supply a frame kit as an option). In either case the mounting surface should be a non combustible flat and level surface capable of supporting the weight of the boiler when full of water and any additional ancillary equipment. The boiler is supplied with a wall mounting plate which should be fixed to a wall using fixings appropriate to the wall construction. (Not Hamworthy supply).

Any combustible material adjacent to the boiler and the flue system must be so placed or shielded to ensure that its temperature does not exceed 65°C.

*Further details regarding boiler location are given in BS 6644. & BS 5440 part 2.*

### Water Systems

Fleet boilers are suitable for installation in sealed heating systems or open vented systems. However in the interests of system cleanliness, ease of maintenance, water quality and reduced oxygen ingress Hamworthy strongly recommend sealed systems are considered for use where ever possible.

If open vented systems must be used, the height of the feed and expansion tank as well as the height of the open vent pipe must be designed correctly.

*See advice on page 15.*

## Open Vented Systems

With open vented systems there are a number of key considerations to ensure satisfactory operation of the boilers:

- Height of the feed and expansion tank above the boilers
- Height of the open vent pipe above the feed and expansion tank water level
- Open vent and cold feed pipe size
- Volume of feed and expansion tank
- Structural integrity of building to support feed and expansion tank weight

**Hamworthy strongly recommend sealed systems are considered where ever possible.**

### Tank Height

Health and Safety Executive Guidance Note PM5 states that "hot water boilers should have an automatic control apparatus to cut off fuel to the burners of gas fired plant when the water at or near the boiler flow outlet rises to a pre-determined temperature.

This should provide a margin of at least 17°C below the temperature of saturated steam corresponding to the pressure at the highest point of the circulation system above the boiler."

To comply with this recommendation, the minimum system pressure is dependent on system design flow temperatures and in the case of modular installations, the temperature rise across each module.

### Single Installations

The minimum pressure must be equal to the gauge pressure equivalent to the saturated steam temperature obtained by adding 17°C to the required boiler flow temperature. The highest point of the circulation system above the boiler should never be less than 2m (6.5ft).

- Required flow temperature 90°C
- Safety margin 17°C
- Equivalent saturated steam temperature 107°C

**From steam tables corresponding gauge pressure 0.3 bar – 3.0m head of water.**

### Modular Installation

The minimum pressure at the highest point of the circulating system should be equal to the gauge pressure equivalent to the temperature of saturated steam at this point. The temperature of saturated steam is obtained by adding 17°C to the required flow temperature from the boilers.

Example:

- Required flow temperature from boilers 80°C
- Safety margin 17°C
- Equivalent saturated steam temperature 97°C

**From steam tables corresponding gauge pressure to be present at the highest point of the circulating system = 0.09bar – 0.92m**

**System head available at Fleet boilers must never be less than 0.5 bar – 5.1m.**

### Open Vent Pipe Height

The height of the open vent pipe discharge above the feed and expansion tank water level must be sufficient to absorb the residual head pressure surge from the boiler pump on initial start up.

The boiler pump is sized to overcome the boiler hydraulic resistance and to provide additional head to overcome system resistance. This additional head for the heating system is the residual pump head which upon pump start up will cause a momentary rise in water level within the open vent pipe whilst circulation around the system gets going. The height of the open vent pipe discharge above the water level within the tank must be greater than the equivalent residual pump head.

### Residual Pump Head

Boiler model	Residual pump head (m)
F40W	0.27
F50W	0.20
F60W	0.14
F70W	0.06
F85W	0.42
F100W	0.34
F125W	0.22
F150W	0.30

### Open Vent & Cold Feed

Every boiler or group of boilers should have an open vent pipe and cold feed pipe installed between the boiler and the first water isolating valve. The minimum bore of these pipes per installation is shown in the table below. Refer to BS 6644 for further information.

Boiler output	Open Vent Size	Cold Feed Size
<60kW	25mm	19mm
60kW – 150kW	32mm	25mm
150kW – 300kW	38mm	32mm
300kW – 600kW	50mm	38mm

## Sealed Systems

Compliance with the requirements of Health and Safety Executive Guidance Note PM5 can also be assured by using an automatic pressurisation unit with expansion vessel, such as the Hamworthy Chesil range of pressurisation units.

Such units can be set to ensure minimum head requirements are maintained and provide alarm facilities for high and low system pressure with interlock circuits for the boiler plant.

Expansion vessels for sealed systems must be sized to suit the system volume to which they are attached as well as maintaining hot working pressure within the maximum operating limits of the plant.

*For more details regarding sealed systems and pressurisation units, see publication 500002486 Hamworthy Chesil Pressurisation Units.*

# Application & System Data

## Fleet Wall Hung Boilers

### Gas Supply Pipes

Supply pipes must be fitted in accordance with BS6891 or IGE/UP/2 as appropriate. Pipework must be of adequate size. Pipes should not be of a smaller size than the boiler gas connections. The complete installation must be purged and tested for soundness as described in BS6891 or IGE/UP/1 and IGE/UP/1A as appropriate.

The information in table 1 opposite shows pipe lengths from gas meter outlet to appliance which will produce approx. 1mbar pressure loss. This table must be used in conjunction with losses of various fittings shown in table 2 below.

Note: Table 1 is based on CIBSE guidance for flow of natural gas in medium grade steel pipes and does not include allowance for any pipe fittings i.e. a straight continuous pipe.

Allowances for basic pipe fittings are provided in table 2 and must be subtracted from the maximum pipe length derived from table 1.

This information is provided for guidance only and does not replace the requirement for full and accurate pipe sizing to suit the site layout and boilers in use.

### Adequate Water Flow

The Fleet boiler is designed as a rapid response, low water content unit, to run continuously with maximum reliability. Care should be taken in the initial design and layout, having due regard for adequate water flow through the boilers, and the influence of the control system.

Fleet boilers are equipped with individually matched pumps designed for 20°C differential temperature across the boiler.

Hamworthy strongly recommend that Fleet boilers are installed using a primary circuit design to ensure secondary circuit conditions cannot have influence over reliable operation of the boilers.

**Table 1- CIBSE guidance for flow of natural gas in medium grade steel pipes**

Boiler Output kW	Maximum length of gas pipe (metres)					
	Pipe diameter					
	25mm	40mm	50mm	65mm	80mm	100mm
40	43					
50	30	222				
60	22	166				
70	16	128				
85		90	295			
100		65	217			
125		37	142			
150		33	104			
175		26	74	285		
200		20	62	216		
225		16	52	178		
250			43	147		
275			35	125	270	
300			30	109	222	
325			26	77	206	
350			23	69	178	
375			21	65	158	
400			19	61	140	
425				57	125	
450				52	116	
475				47	102	458
500				43	93	380
525				39	82	342
550				36	73	307
575				33	69	270
600				31	66	250

**Table 2 - Allowances for basic pipe fittings**

Fitting	Pipe length reduction per fitting (metres)					
	Pipe diameter					
	25mm	40mm	50mm	65mm	80mm	100mm
Elbow	0.5	1.0	1.5	2.0	2.5	3.5
Tee	0.5	1.0	1.5	2.0	2.5	3.5
Radius bend	0.3	0.3	0.5	0.5	1.0	1.5

## System Feed Water Quality

Modern heating systems often contain a diverse mix of metals, which when combined with the varying chemical composition of supply water, can lead to corrosion. It is therefore important to treat water, where required, to ensure long term satisfactory operation of the boilers and heating system.

Hamworthy recommend a water treatment specialist is appointed to undertake analysis of the water and to recommend suitable cleaning and dosing regimes, to ensure the quality of system and make up water remains within the following tolerances throughout the life of the installation:

Water Properties	Permitted Levels
Acidity level	7 to 8 pH (untreated) 7 to 8.5 pH (treated)
Chlorides (Cl)	≤ 150 mg/l
Calcium Carbonate (CaCO <sub>3</sub> )	< 300ppm
Iron (Fe)	≤ 125 ppm (treated)
Copper (Cu)	≤ 1 ppm (treated)
Aluminium (Al)	≤ 1 ppm (treated)
Conductivity	≤ 800µs/cm at 25°C

\* Total boiler output

As a minimum, system pipe work must be flushed twice with suitable flushing and cleaning agents as recommended by the water treatment specialist. Artificially softened water must be avoided when filling the system. Chemical dosing to avoid corrosion and bacterial growth should be in accordance with the recommendations of the appointed water treatment specialist. To prevent dilution of water treatment in normal operation, it is essential to monitor make up water usage and attend to leaks quickly. Any draining of the system must be co-ordinated with subsequent re-dosing with the correct chemicals to ensure protection is not compromised.

Additionally, a coarse filter and dirt separator must be fitted in the return pipe work close to the boilers, and suitable air separation must be provided at high points in the distribution circuits.

*Full details for water quality requirements are available on request.*

## Condensate Discharge

Natural Gas condensing boilers typically produce condensate at a rate of around 13litres per hour per 100kW input energy, when operating at suitable temperatures.

A drain connection is fitted to the boiler to enable the disposal of the condensate which is mildly acidic, with a typical value 3.5pH, and can be disposed of normally through the drainage system. If in any doubt about local regulations, check with the local water authority.

The condensate drain on each boiler must be connected to a suitable drainage system using corrosion resistant material such as a PVC plastic with glued sealed joints, to prevent the escape of condensate.

Drain traps and an open tundish should be incorporated into the design, and the pipework given appropriate protection from physical damage and frost.

The pipework should be installed with at least a 3 degrees fall (approximately 50mm per metre).

The Fleet optional frame-set and pipe kit includes plastic pipework to connect the drain from each boiler to a single pipe which should be piped away to a drain in the manner described above. *Refer to page 7 for further details of optional pipe kits.*

## The Building Regulations 2010

Approved Document L2A – Conservation of fuel and power in new buildings other than dwellings.

Approved Document L2B – Conservation of fuel and power in existing buildings other than dwellings

These new regulations came into force 1st October 2010. Compliance with the latest regulations requires a whole building approach to reduction in carbon emissions. The 2010 edition requires the use of heat generating plant as detailed in the supporting 2nd tier guide: Non-Domestic Building Services Compliance Guide

## Seasonal Efficiency

The efficiency data used for evaluating commercial boilers is known as the 'boiler seasonal efficiency' and is calculated using a combination of gross operating efficiency data at both part and full load.

## New Buildings

For Natural Gas, single boiler installations must have a gross boiler seasonal efficiency no less than 86%.

For Natural Gas, multiple boilers installations must have no individual gross boiler seasonal efficiency less than 82%, with the combined gross boiler seasonal efficiency no less than 86%.

## Existing Buildings

For Natural Gas, single boiler installations must have a gross boiler seasonal efficiency no less than 82%.

For Natural Gas, multiple boiler installations may have individual gross boiler seasonal efficiency less than 82%, with the combined boiler seasonal efficiency no less than 82%.

For Natural Gas, all existing building installations must have an 'effective boiler seasonal efficiency' no less than 84%. Where the boiler seasonal efficiency for single and multiple boiler installations lies between 82% and 84%, additional credits can be gained to effectively increase the boiler seasonal efficiency.

*For full details of available credits, refer to the Non-Domestic Building Services Compliance Guide 2010 Edition.*

# Air Supply & Ventilation

## Fleet Wall Hung Boilers

An adequate supply of fresh air for combustion and ventilation must be provided in accordance with BS5440 and BS6644. Where Fleet boilers are installed as room sealed units the air supply is for ventilation only.

### Boiler Installations <70kW Nett Rated Input

Air supply and ventilation must be in accordance with BS5440

Model	Compartment Ventilation – Open Flue		Compartment Ventilation – Room Sealed	
	Direct to outside air	To room or internal space	Direct to outside air	To room or internal space
Fleet F40W Nett heat input 37kW	High level - 185cm <sup>2</sup>	High level - 370cm <sup>2</sup>	High level - 185cm <sup>2</sup>	High level - 370cm <sup>2</sup>
	Low level - 370cm <sup>2</sup>	Low level - 740cm <sup>2</sup>	Low level - 185cm <sup>2</sup>	Low level - 370cm <sup>2</sup>
Fleet F50W Nett heat input 46kW	High level - 230cm <sup>2</sup>	High level - 460cm <sup>2</sup>	High level - 230cm <sup>2</sup>	High level - 460cm <sup>2</sup>
	Low level - 460cm <sup>2</sup>	Low level - 920cm <sup>2</sup>	Low level - 230cm <sup>2</sup>	Low level - 460cm <sup>2</sup>
Fleet F60W Nett heat input 56kW	High level - 280cm <sup>2</sup>	High level - 560cm <sup>2</sup>	High level - 280cm <sup>2</sup>	High level - 560cm <sup>2</sup>
	Low level - 560cm <sup>2</sup>	Low level - 1120cm <sup>2</sup>	Low level - 280cm <sup>2</sup>	Low level - 560cm <sup>2</sup>
Fleet F70W Nett heat input 65kW	High level - 325cm <sup>2</sup>	High level - 650cm <sup>2</sup>	High level - 325cm <sup>2</sup>	High level - 650cm <sup>2</sup>
	Low level - 650cm <sup>2</sup>	Low level - 1300cm <sup>2</sup>	Low level - 325cm <sup>2</sup>	Low level - 650cm <sup>2</sup>

The areas quoted are minimum free areas for ventilation grilles. For further guidance refer to BS5440.

### Boiler Installations >70kW Nett Rated Input

Air supply and ventilation must be in accordance with BS6644

#### Open Flue Appliances

Compartment Ventilation - Open Flue	Boiler House Ventilation - Open Flue
Direct to outside air	Direct to outside air
High level - 5cm <sup>2</sup> /kW nett input	High level - 2cm <sup>2</sup> /kW nett input
Low level - 10cm <sup>2</sup> /kW nett input	Low level - 4cm <sup>2</sup> /kW nett input

#### Room Sealed Appliances

Compartment Ventilation - Room Sealed	Compartment Ventilation - Room Sealed	Boiler House Ventilation - Room Sealed
Direct to outside air	To room or internal space	Direct to outside air
High level - typically 5cm <sup>2</sup> /kW nett input	High level - typically 10cm <sup>2</sup> /kW nett input	High level - typically 2cm <sup>2</sup> /kW nett input
Low level - typically 5cm <sup>2</sup> /kW nett input	Low level - typically 10cm <sup>2</sup> /kW nett input	Low level - typically 2cm <sup>2</sup> /kW nett input

The areas quoted are minimum free areas for ventilation grilles. For nett heat input, refer to technical data table on page 8. For further guidance refer to BS6644.

## General Ventilation Requirements

### Boiler House Temperatures

Additional requirement of BS6644 for multiple boiler installation requires that the air supplied for boiler house ventilation shall be such that the maximum temperatures within the boiler house do not exceed:

- At floor level 25°C  
(or 100mm above floor level)
- At mid level 32°C  
(1.5m above floor level)
- At ceiling height 40°C  
(or 100mm below ceiling height)

### Ventilation Grille Openings

High and low level ventilation grilles shall be positioned as high and as low as practicably possible. Low level grilles additionally will be located within 1 metre of floor level for Natural Gas. High level grilles are recommended to be positioned within 15% of the boiler room height from the ceiling.

High and low level ventilation grilles shall communicate with the same room or internal space where compartment ventilation is used.

Where ventilation grilles communicate directly with outside air they shall be positioned on the same wall.

### Air Supply

The air supply should be free from contamination such as building dust and insulation fibres from lagging.

To avoid unnecessary cleaning and servicing of the boiler modules the boilers should not be fired whilst building work is being undertaken. Where a boiler installation is to operate throughout the summer months, e.g. for domestic hot water production for more than 50% of the time, then additional ventilation allowances are required. Refer to BS6644 for more information.

# Wiring Diagram

## Fleet Wall Hung Boilers

The following electrical connections are provided on each boiler:

- Supply live neutral and earth
- Boiler general fault alarm signal output
- Boiler normal run signal output
- 0 – 10v analog control signal input
- Remote on/off control input
- Remote safety interlock circuit input

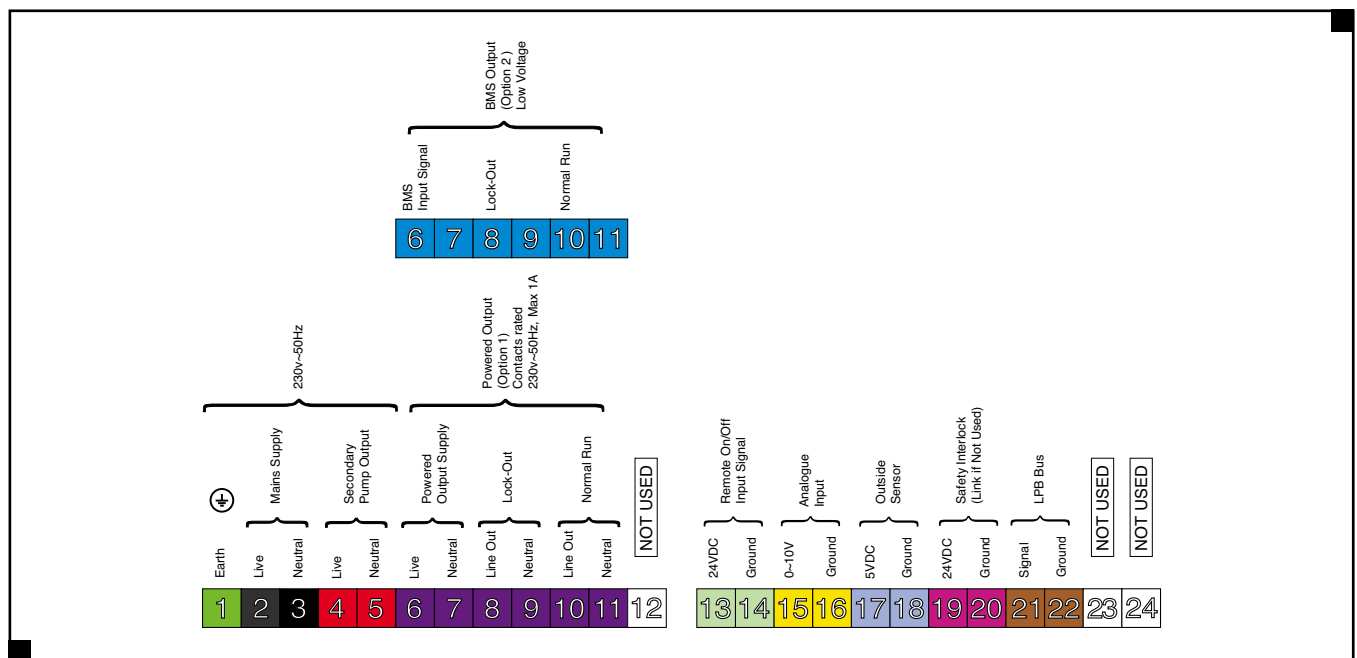

### Electrical Supply

An independent isolator and fused electrical supply is recommended for each boiler. Supply 230 volt, 50Hz, single phase. Wiring external to the boiler must be installed in accordance with IEE Regulations and any local regulations which apply. Wiring must be completed in heat resistant 3 core cable, (size 1.0 mm<sup>2</sup> c.s.a.). Fascia fuse rating is 2 amp. External fuses should be rated 6 amps for each boiler.

To prevent drawings excessive current (>1 amp) through the boiler control panel, it is recommended that external pumps are connected via contactors.

### Electrical Connections

There is a gland plate fitted in the bottom of the boiler mounting frame to accept cables for power supply and controls.

A single terminal rail is fitted inside the front cover, and all external connections are made to this terminal rail.

### Remote Signalling

Volt free contacts are provided to indicate the following operating conditions:

- Boiler normal run
- Boiler general fault

### 0-10 Volt DC Analog Input

A 0-10 volt DC analog signal interface is provided to control boiler from an external Building Management System (BMS).

The interface can be configured to control the boiler according to either power requirement or temperature requirement.

### Remote on/off

Facilitating control from an external source the remote on/off circuit is powered at 24V DC and requires a volt free contact device to enable/disable operation. The boiler will operate using its own internal temperature regulation controls in remote on/off operation mode.

### Remote Safety Interlock

Safety devices such as pressurisation units, flue fans etc can be interlocked with boilers using a 24V DC circuit requiring a volt free contact device to permit/prevent operation.

# System Design

## Fleet Wall Hung Boilers

### Primary Circuit Layout

Fleet boilers have an integral boiler pump and so it is not necessary to include a dedicated primary circuit pump in the hydraulic layout. The integral pump guarantees correct flow rates through each boiler, therefore reverse return pipe work design in the primary circuit is not a requirement, simplifying the design and installation.

The primary circuit pipe system must be designed to ensure the residual head of the boiler pumps is sufficient to overcome hydraulic resistance of the pipework at maximum flow rate.

When installing Fleet boilers in existing buildings, heating systems must be thoroughly flushed before installing the boilers. Additional measures to safeguard the boilers from existing system debris should include a dirt and air separator in the return pipe from secondary circuits. When using the optional frame and pipe kit and low loss header for 3 secondary circuits, a dirt and air separator should be included in the return pipe from each circuit, to ensure system debris is prevented from reaching the boilers.

Optional low loss header kits have provision for temperature sensors which may be used in conjunction with sequence controllers or site BMS controls. A pocket is provided in the primary flow and return with capacity for up to 3 x 6mm sensing elements in each.

It is important to maintain corrosion inhibitor levels throughout the working life of the boiler installation. Correct inhibitor levels also help to keep the boiler clean and prevent drops in efficiency associated with sedimentation. To make this process simple a dosing pot is recommended, located in a position providing for ease of access.

*For details of system feed water quality, refer to page 17.*

### Hamworthy optional pipe kit with low loss header for single secondary circuit

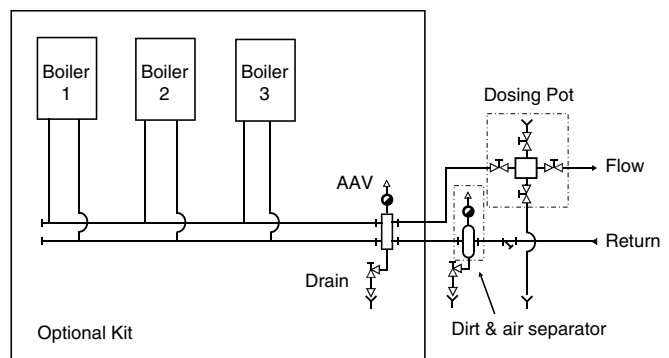

*Note: - secondary circuit components are not supplied with the HHL pipe kit.*

### Hamworthy optional pipe kit with low loss header for three secondary circuits

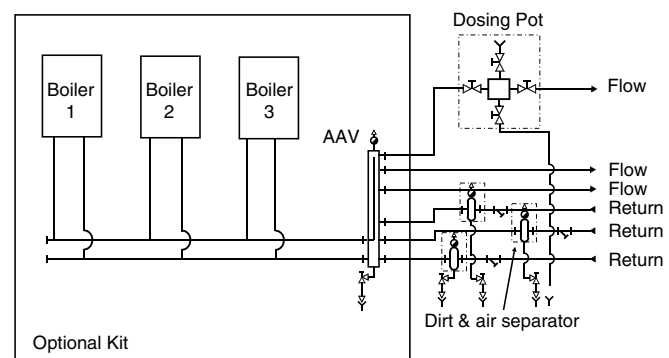

*Note: - secondary circuit components are not supplied with the HHL pipe kit.*

### Typical primary circuit arrangement with low loss header

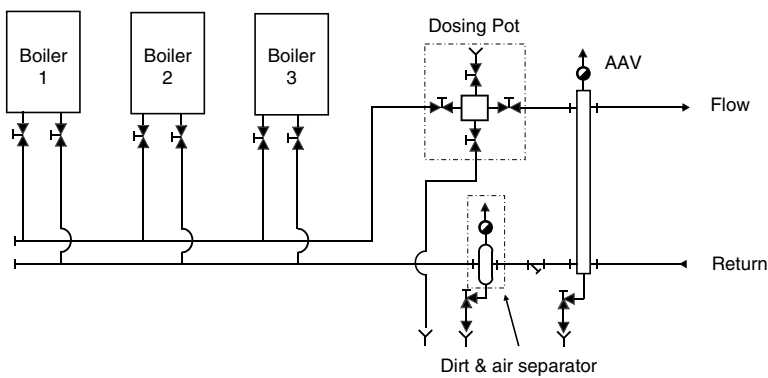

When installing Fleet wall hung boilers without the optional frame and pipe kits, provision should be made for fitting any required instrumentation such as gauges or temperature sensor pockets. Temperature sensors for sequence controllers or BMS controls for the boiler should be located in the primary flow and return between the boiler and low loss header.

Adequate provision should be made for isolating the boilers for the purpose of future maintenance. If using the optional frame and pipe kits, all isolating valves are provided for hydraulic and gas services.

With older systems it can be advantageous to totally separate the boilers from the secondary circuits using a plate heat exchanger. This method of connection helps to prevent sedimentation within the boilers and for chemical dosing of the boilers to remain unaffected by conditions elsewhere within the heating system. Using a plate heat exchanger also assures good heat transfer from primary to secondary heating circuits with minimal losses. Plate heat exchangers for this purpose should ideally be non-brazed allowing for future maintenance and cleaning.

### Hydraulic separation of secondary circuits using a plate heat exchanger

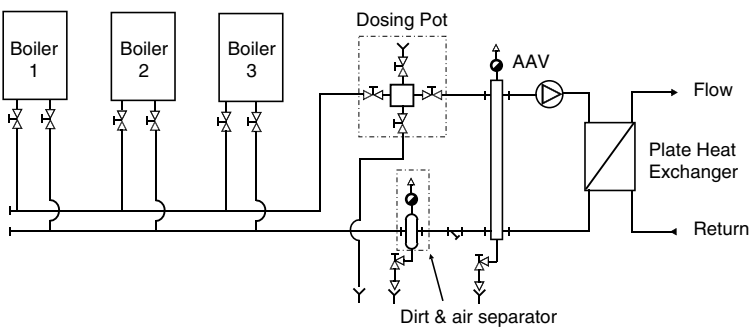

# Flue Design

Fleet Wall Hung Boilers  
 Concentric Room Sealed Flue Systems  
 C13 Horizontal Terminal

## C13 Horizontal Room Sealed Standard flue terminal kit: Diagram 1

The C13 standard flue terminal kit includes the boiler connection elbow, terminal and wall plates, shown as shaded items. This kit can be fitted in left hand, right hand, or rear orientation. If the flue terminal kit is insufficient in overall length to reach the desired terminal location, an extendable flue terminal kit is available, see diagram 2.

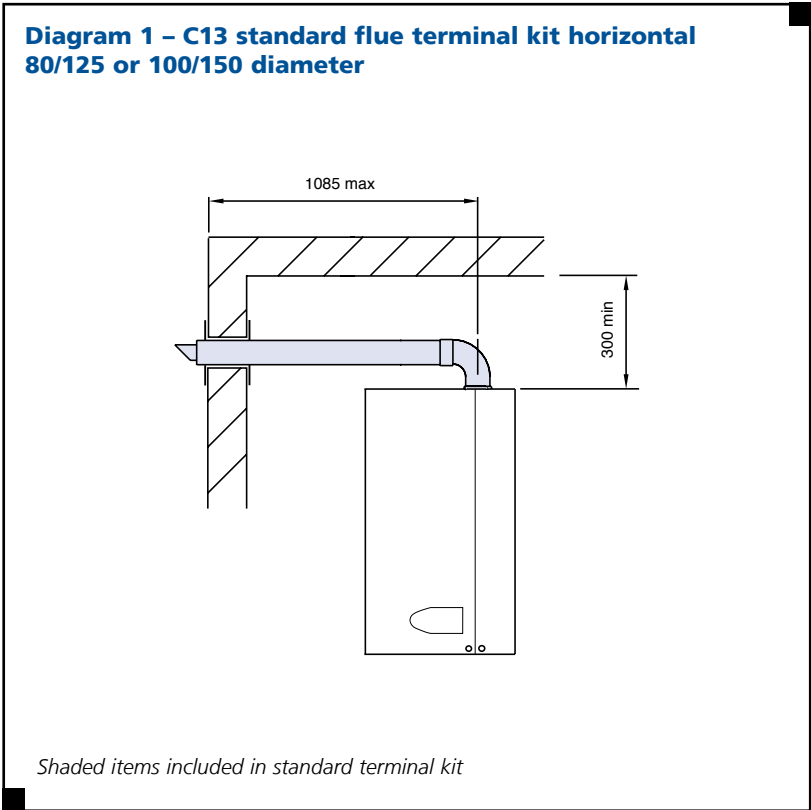

## C13 Horizontal Room Sealed Extendable flue terminal kit: Diagram 2

The C13 extendable flue terminal kit includes the boiler connection elbow, terminal, wall plates, condensate drain fitting, and for models F40W to F100W with 100/150 diameter flue, the boiler connection expansion adaptor. See shaded items in diagram 2. This may be extended to reach the desired terminal location by adding intermediate flue components, however, 'equivalent length' component details, as shown in the tables on page 23, must be observed when adding flue lengths and elbows, so that the maximum flue length is not exceeded. Extendable flue systems must be fitted with a condensate drain fitting close to the boiler.

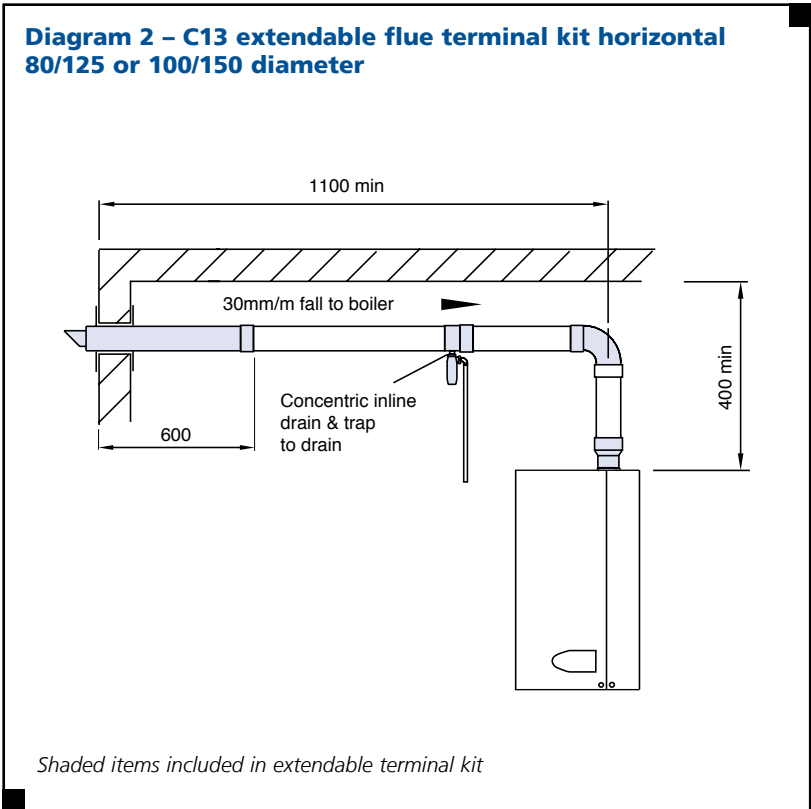

# Flue Design

Fleet Wall Hung Boilers  
Concentric Room Sealed Flue Systems  
C13 Horizontal Terminal

Model	Flue Dia. (mm)	Max Flue Length (m)	Equivalent Length (m)		
			45° Elbow	90° Elbow	Condense Drain
F40W	80/125	30	0.75	1	0.5
	100/150	60	0.5	0.75	0.5
F50W	80/125	20	0.75	1	0.5
	100/150	40	0.5	0.75	0.5
F60W	80/125	13	1.5	2	0.5
	100/150	30	0.75	1	0.5
F70W	80/125	9	1.5	2	0.5
	100/150	20	0.75	1	0.5
F85W	80/125	4	2	3	0.5
	100/150	15	0.75	1	0.5
F100W	80/125	1	3	4	0.75
	100/150	10	1	1.5	0.75
F125W	100/150	7	1	1.5	0.75
F150W	100/150	4	1	1.5	0.75

## Concentric flue and terminal kits 80/125 mm diameter Boiler models F40W to F100W only

Item	Diameter (mm)	Part number
Flue terminal C13 horizontal Standard kit – models F40W to F100W	80/125	532511155
Flue terminal C13 horizontal Extendable kit - models F40W to F100W	80/125	562511032
Flue elbow 90°	80/125	532511124
Flue elbow 45°	80/125	532511123
Flue pipe 1000mm long	80/125	532511139
Flue wall bracket	125	532511016

## Concentric flue and terminal kits 100/150 mm diameter Boiler models F40W to F150W

Item	Diameter (mm)	Part number
Flue terminal C13 horizontal Standard kit – models F125W to F150W	100/150	532511153
Flue terminal C13 horizontal Extendable kit – models F40W to F100W	100/150	562511029
Flue terminal C13 horizontal Extendable kit – models F125W to F150W	100/150	562511076
Flue elbow 90°	100/150	532511118
Flue elbow 45°	100/150	532511116
Flue pipe 1000mm long	100/150	532511132
Flue wall bracket	150	532511033

### Concentric Flue Runs

The flue run from the boiler to the terminal can be made using concentric tubes with flue gases being expelled through the inner duct and combustion air drawn in to the appliance via the outer annulus.

The flue components are manufactured in polypropylene with EPDM joint seals and are not UV stabilised so therefore only suitable for use internally.

*Where flue systems must be run or located externally please contact our technical team for further assistance. Tel 01202 662500.*

### Flue Terminals

Horizontal flue terminals are manufactured with enamelled galvanized steel outer skin and are suitable for external location.

The horizontal flue terminal kit includes an internal and external wall plate for finishing the installation.

### Equivalent Length Components

For single, or individually flued multiple boilers, it is possible to select components from the Hamworthy range of polypropylene flue components, and design a flue system that has an overall length within the specified limits.

The maximum flue length is the sum of all the vertical and horizontal flue sections, plus the equivalent lengths of all the 90 degree and 45 degree elbows.

The tables shown in this Flue Design section provide details of the flue system maximum lengths, and the equivalent lengths for elbows, for each of the flue system types.

# Flue Design

Fleet Wall Hung Boilers  
 Concentric Room Sealed Flue Systems  
 C33 Vertical Terminal

## C33 Vertical Room Sealed Extendable flue terminal kit: Diagram 3

The C33 extendable flue terminal kit includes the terminal, condensate drain fitting and for models F40W to F100W with 100/150 diameter flue, the boiler connection expansion adaptor. See shaded items in diagram 3. This may be extended to reach the desired terminal location by adding intermediate flue components, however, 'equivalent length' component details, as shown in the tables on page 25, must be observed when adding flue lengths and elbows, so that the maximum flue length is not exceeded.

Extendable flue systems must be fitted with a condensate drain fitting close to the boiler.

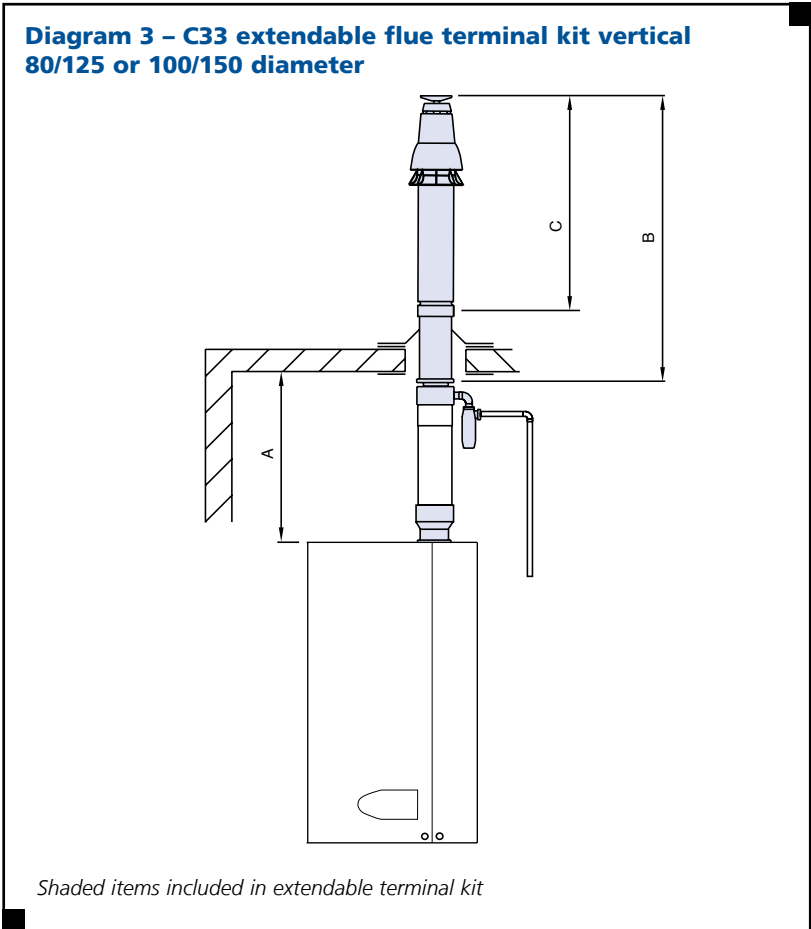

C33 extendable flue terminal kit 80/125 or 100/150 diameter (mm)			
Diameter	A	B	C
80/125	600 Min.	1350	580
100/150	600 Min.	1730	930

### How to order flue components

Often flue components are ordered separately from the main boiler equipment and so to simplify the flue ordering process, Hamworthy have a flue order form available for you to call off all your flue component requirements.

To request a Fleet flue system order form, telephone 0845 450 2865 or email [sales@hamworthy-heating.com](mailto:sales@hamworthy-heating.com) and state which flue system you are planning to use:

#### Fleet Wall Hung

- Concentric room sealed - C13 with horizontal terminal (wall)
- Concentric room sealed - C33 with vertical terminal (roof)
- Twin duct room sealed - C53 with horizontal or vertical terminal
- Open flue - B23 with horizontal or vertical terminal or existing chimney
- Open flue with header - B23 with horizontal or vertical terminal or existing chimney

# Flue Design

Fleet Wall Hung Boilers  
Concentric Room Sealed Flue Systems  
C33 Vertical Terminal

Model	Flue Dia. (mm)	Max Flue Length (m)	Equivalent Length (m)		
			45° Elbow	90° Elbow	Condense Drain
F40W	80/125	30	0.75	1	0.5
	100/150	60	0.5	0.75	0.5
F50W	80/125	20	0.75	1	0.5
	100/150	40	0.5	0.75	0.5
F60W	80/125	13	1.5	2	0.5
	100/150	30	0.75	1	0.5
F70W	80/125	9	1.5	2	0.5
	100/150	20	0.75	1	0.5
F85W	80/125	4	2	3	0.5
	100/150	15	0.75	1	0.5
F100W	80/125	1	3	4	0.75
	100/150	10	1	1.5	0.75
F125W	100/150	7	1	1.5	0.75
F150W	100/150	4	1	1.5	0.75

### Concentric flue and terminal kits 80/125 mm diameter Boiler models F40W to F100W only

Item	Diameter (mm)	Part number
Flue terminal C33 vertical Extendable kit – models F40W to F100W	80/125	562511039
Flue elbow 90°	80/125	532511124
Flue elbow 45°	80/125	532511123
Flue pipe 1000mm long	80/125	532511139
Flue wall bracket	125	532511016
Flue flat roof flashing	125	532511173
Flue pitched roof flashing	125	532511177

### Concentric flue and terminal kits 100/150 mm diameter Boiler models F40W to F150W

Item	Diameter (mm)	Part number
Flue terminal kit C33 vertical Extendable kit – models F40W to F100W	100/150	562511034
Flue terminal C33 vertical Extendable kit – models F125W to F150W	100/150	562511035
Flue elbow 90°	100/150	532511118
Flue elbow 45°	100/150	532511116
Flue pipe 1000mm long	100/150	532511132
Flue wall bracket	150	532511033
Flue flat roof flashing	150	532511174
Flue pitched roof flashing	150	532511178

### Concentric Flue Runs

The flue run from the boiler to the terminal can be made using concentric tubes with flue gases being expelled through the inner duct and combustion air drawn in to the appliance via the outer annulus.

The flue components are manufactured in polypropylene with EPDM joint seals and are not UV stabilised so therefore only suitable for use internally.

Where flue systems must be run or located externally please contact our technical team for further assistance. Tel 01202 662500.

### Flue Terminals

Vertical flue terminals are manufactured with enamelled galvanized steel outer skin and are suitable for external location. With vertical flue terminals for type C33 flue systems, the length of flue suitable for external location is shown in the drawing below – dimension C.

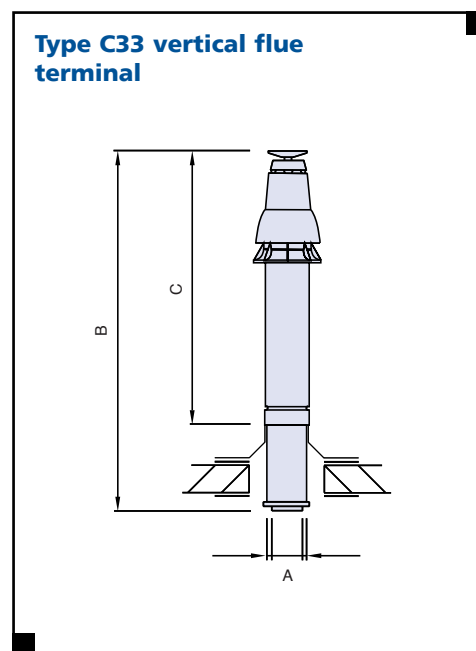

Type C33 vertical flue terminal Dimensions (mm)		
A	B	C
80/125	1350	580
100/150	1730	930

# Flue Design

Fleet Wall Hung Boilers  
 Single Wall Flue Systems  
 C53 Twin Duct Room Sealed

## C53 Room Sealed Extendable twin pipe flue terminal kits Diagrams 4 and 5

The C53 flue terminal kit is supplied with air inlet terminal, flue terminal, elbows, boiler connector and condensate drain fitting. See shaded items in diagrams 4 & 5. This may be extended to reach the desired terminal location by adding intermediate flue components, however, 'equivalent length' component details, as shown in the tables on page 27, must be observed when adding flue lengths and elbows, so that the maximum flue length is not exceeded.

Air inlet terminals are designed for wall mounted location only whilst flue pipes may be terminated either on a wall or at roof level. Extendable flue systems must be fitted with a condensate drain fitting close to the boiler.

**Diagram 4 – C53 extendable flue terminal kit horizontal 100 and 130 diameter**

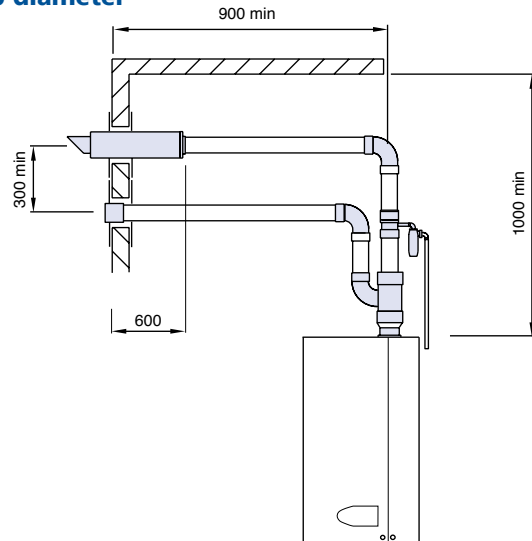

*Shaded items included in terminal kit*

**Type C53 vertical flue terminal**

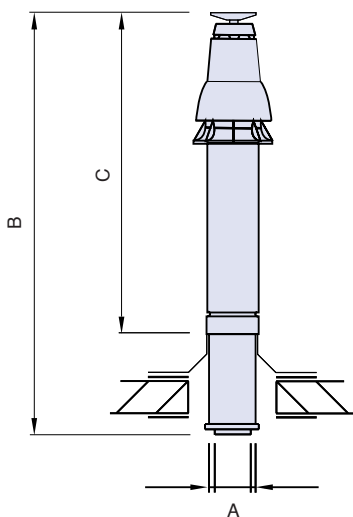

**Diagram 5 – C53 extendable flue terminal kit vertical 100 and 130 diameter**

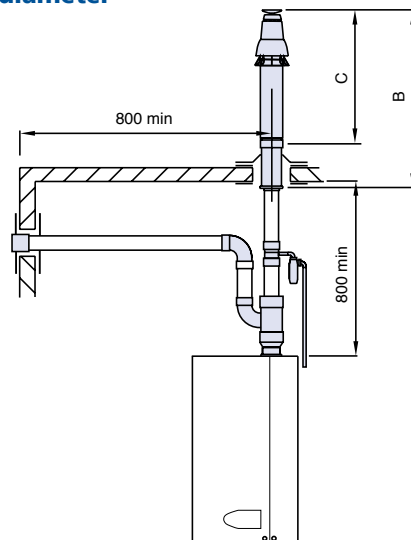

*Shaded items included in terminal kit*

**C53 extendable flue terminal  
 100 and 130 diameter (mm)**

A	B	C
100	1730	930
130	1800	920

# Flue Design

Fleet Wall Hung Boilers  
Single Wall Flue Systems  
C53 Twin Duct Room Sealed

Model	Flue Dia. (mm)	Max Flue Length (m)	Equivalent Lengths (m)		
			45° Elbow	90° Elbow	Condense Drain
F40W	100	100	0.5	0.75	0.5
F50W	100	50	0.5	0.75	0.5
F60W	100	35	0.75	1.0	0.5
F70W	100	28	0.75	1.0	0.5
F85W	100	20	1.0	1.5	0.5
F100W	100	15	1.5	2.0	0.75
F125W	130	100	3.0	4.0	0.75
F150W	130	75	3.0	4.0	0.75

## Twin duct flue components and concentric terminal kits 100mm diameter

Item	Diameter (mm)	Part number
Flue and air terminal kit C53 vertical – models F40W – F100W	100/150	562511041
Flue and air terminal kit C53 horizontal – models F40W – F100W	100/150	562511045
Flue elbow 90°	100	532511115
Flue elbow 45°	100	532511114
Flue pipe 1000mm long	100	532511130
Flue pipe 2000mm long	100	532511131
Flue wall bracket	100	532511017
Flue flat roof flashing	150	532511174
Flue pitched roof flashing 25° to 45°	150	532511178

## Twin duct flue components and concentric terminal kits 130mm diameter

Item	Diameter (mm)	Part number
Flue terminal kit C53 vertical – models F125W – F150W	130/200	562511043
Flue terminal kit C53 horizontal – models F125W – F150W	130/200	562511047
Flue elbow 90°	130	532511120
Flue elbow 45°	130	532511119
Flue pipe 1000mm long	130	532511133
Flue wall bracket	130	532511184
Flue flat roof flashing	200	532511175
Flue pitched roof flashing 25° to 30°	200	532511179
Flue pitched roof flashing 31° to 47°	200	532511180
Flue pitched roof flashing 48° to 52°	200	532511181

## Twin Duct Flue Runs

Single wall flue components are used to create separate ducts for connecting the boiler to the air inlet and flue terminals.

In the twin duct system, the air supply is drawn into the boiler through one duct, whilst the flue gases are exhausted through the other.

The flue components are manufactured in polypropylene with EPDM joint seals and are not UV stabilised so therefore only suitable for use internally.

Where flue systems must be run or located externally, please contact our technical team for further assistance. Tel 01202 662500.

## Air Inlet and Flue Terminals

The twin duct system utilises the same flue terminals as concentric flue systems for both vertical and horizontal discharge. The concentric air inlet connection is not used and a cap is provided to seal off the outer air intake annulus and prevent heat loss. The flue duct is connected to the inner pipe.

A separate air inlet terminal is supplied with the C53 flue terminal kit, for connecting to the air duct which runs to the boiler.

Air inlet terminals are designed for horizontal installation in walls only, whilst flue exhaust ducts may be terminated either in a wall horizontally, or through a roof vertically.

Horizontal and vertical flue terminals are manufactured with enamelled galvanized steel outer skin and terminal construction and are suitable for external location.

With vertical flue terminals for type C53 flue systems the length of flue suitable for external location is shown in the drawing on page 26 – dimension C.

The final connection and transition from polypropylene flue pipe to the terminal must be made inside the building.

The horizontal flue terminal kit includes an internal and external wall plate for finishing the installation.

# Flue Design

Fleet Wall Hung Boilers  
 Single Wall Flue Systems  
 B23 Open Flue

## B23 Open Flue Extendable flue terminal kits Diagrams 6 and 7

The B23 flue terminal kit is supplied with terminal, condensate drain fitting, boiler air inlet grille and elbow for horizontal systems. See shaded items in diagrams 6 & 7. This may be extended to reach the desired terminal location by adding intermediate flue components, however, 'equivalent length' component details, as shown in the tables on page 29, must be observed when adding flue lengths and elbows, so that the maximum flue length is not exceeded. Extendable flue systems must be fitted with a condensate drain fitting close to the boiler.

**Diagram 6 – B23 extendable flue terminal kit horizontal  
 100 and 130 diameter**

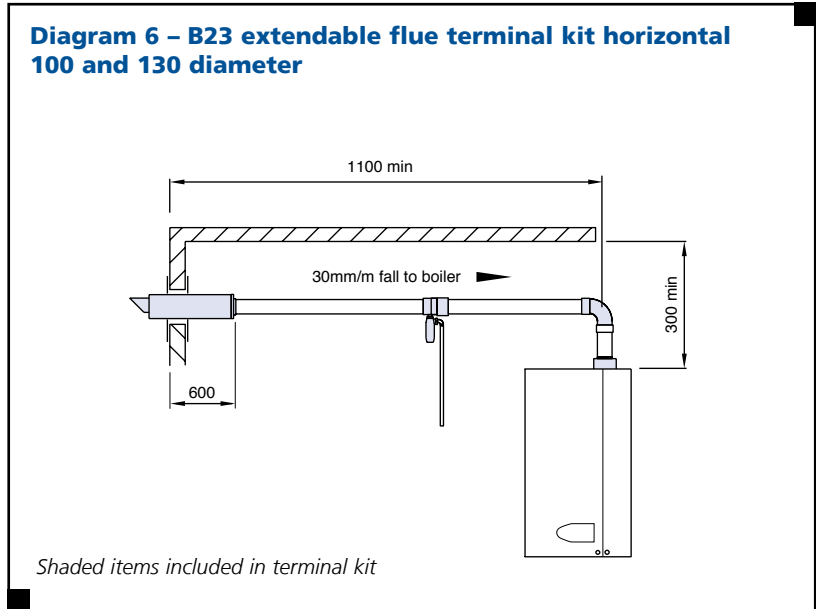

## Type B23 vertical flue terminal

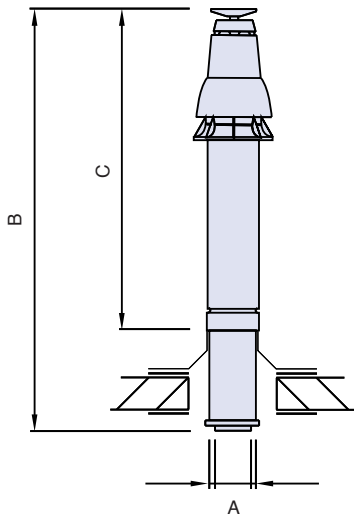

**Diagram 7 – B23 extendable flue terminal kit vertical  
 100 and 130 diameter**

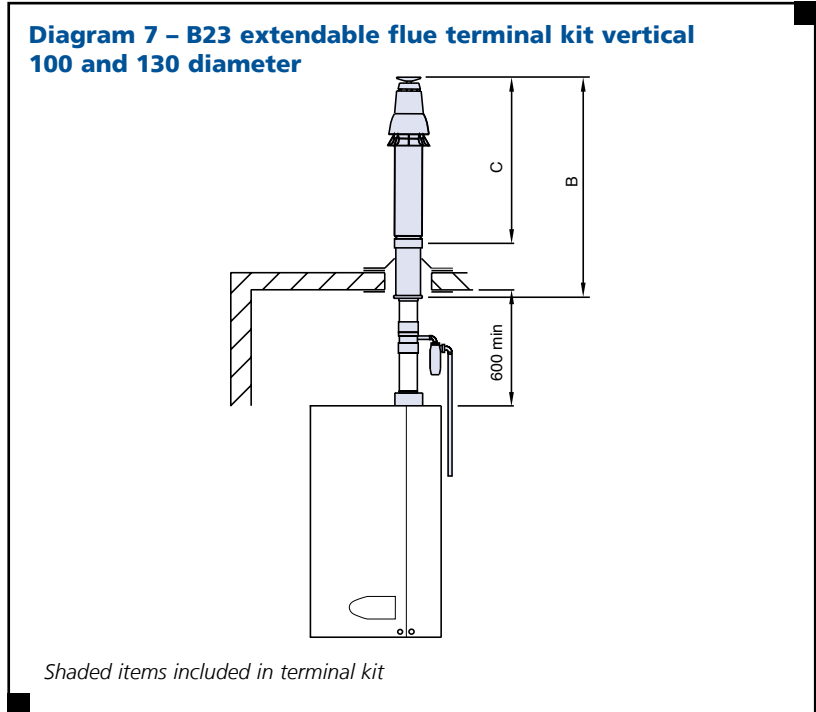

### Type B23 vertical flue terminal Dimensions (mm)

A	B	C
100 (100/150)	1730	930
130 (130/200)	1800	920

# Flue Design

Fleet Wall Hung Boilers  
Single Wall Flue Systems  
B23 Open Flue

Model	Flue Dia. (mm)	Max Flue Length (m)	Equivalent Lengths (m)		
			45° Elbow	90° Elbow	Condense Drain
F40W	100	100	0.5	0.75	0.5
	130	100	0.5	0.75	0.5
F50W	100	50	0.5	0.75	0.5
	130	100	0.5	0.75	0.5
F60W	100	35	0.75	1.0	0.5
	130	100	0.5	0.75	0.5
F70W	100	28	0.75	1.0	0.5
	130	100	0.5	0.75	0.5
F85W	100	20	1.0	1.5	0.5
	130	100	0.75	1.0	0.5
F100W	100	15	1.5	2.0	0.75
	130	100	1.0	1.5	0.75
F125W	100	10	1.5	3.0	0.75
	130	100	3.0	4.0	0.75
F150W	100	6	1.5	3.0	0.75
	130	75	3.0	4.0	0.75

## Open flue components and concentric terminal kits 100mm diameter

Item	Diameter (mm)	Part number
Flue terminal kit B23 vertical – models F40W – F150W	100/150	562511024
Flue terminal kit B23 horizontal – models F40W – F150 W	100/150	562511026
Flue elbow 90°	100	532511115
Flue elbow 45°	100	532511114
Flue pipe 1000mm long	100	532511130
Flue pipe 2000mm long	100	532511131
Flue wall bracket	100	532511017
Flue flat roof flashing	150	532511174
Flue pitched roof flashing 25° to 45°	150	532511178

## Open flue components and concentric terminal kits 130mm diameter

Item	Diameter (mm)	Part number
Flue terminal kit B23 vertical - models F40W – F150W	130/200	562511025
Flue terminal kit B23 horizontal - models F40W – F150W	130/200	562511027
Flue elbow 90°	130	532511120
Flue elbow 45°	130	532511119
Flue pipe 1000mm long	130	532511133
Flue wall bracket	130	532511184
Flue flat roof flashing	200	532511175
Flue pitched roof flashing 25° to 45°	200	532511179

### Flue Runs

Single wall flue components are used to create the flue duct for connecting the boiler to the flue terminal.

The air supply for open flue B23 appliances is drawn in from the top of the boiler casing via the space surrounding the flue connection. A circular cage is provided to ensure debris cannot enter the air intake of the boiler combustion system.

The flue components are manufactured in polypropylene with EPDM joint seals and are not UV stabilised so therefore only suitable for use internally.

Where flue systems must be run or located externally please contact our technical team for further assistance. Tel 01202 662500.

### Flue Terminal

The open flue system utilises the same flue terminals as concentric flue systems for both vertical and horizontal discharge. The concentric air inlet connection is not used and a cap is provided to seal off the outer air intake annulus and prevent heat loss. The flue duct is connected to the inner pipe.

Horizontal and vertical flue terminals are manufactured with enamelled galvanized steel outer skin and terminal construction and are suitable for external location.

With vertical flue terminals for type B23 and C53 flue systems the length of flue suitable for external location is shown in the drawing on page 28 – dimension C.

The final connection and transition from polypropylene flue pipe to the terminal must be made inside the building.

The horizontal flue terminal kit includes an internal and external wall plate for finishing the installation.

# Flue Design

Fleet Wall Hung Boilers  
 Flue Header Systems  
 B23 Open Flue

## B23 Open Flue Header Kits Diagrams 8 & 9

The B23 flue header kit connects 2 boilers to a common flue header. Flue header kits are supplied with all components from the boiler flue outlet connections through to the header itself including the condensate drain kit. See shaded items in diagrams 8 & 9. Flue header kits are available in 150mm diameter and 200mm diameter and must be selected according to installed boiler capacity (kW). Refer to table on page 31. Where larger boiler capacities require longer flue runs, the 200mm diameter flue header system may be increased to 250mm diameter after the header. See diagram 9. In these instances the flue header itself remains 200mm diameter.

## B23 Open Flue Header Extension Kits Diagram 10

Where more than 2 boilers are installed, optional single boiler flue header extension kits are available for both 150mm diameter and 200mm diameter, allowing the flue header system to be extended to accommodate all boilers. See shaded items in diagram 10.

**Diagram 8 - B23 flue header kit for 2 boilers  
 150mm dia.**

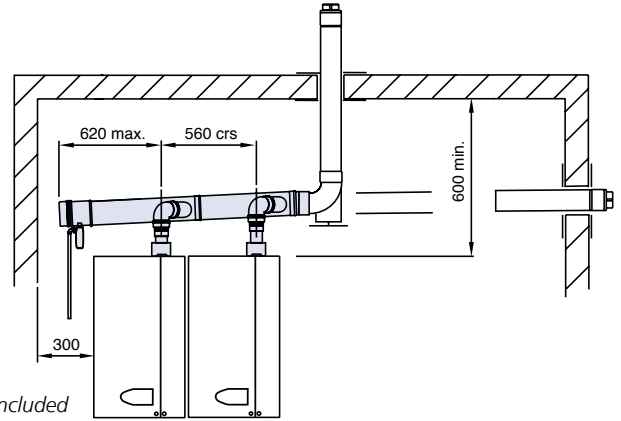

*Shaded items included in header kit*

**Diagram 9 - B23 flue header kit for 2 boilers  
 200mm dia. plus expansion to 250mm dia.**

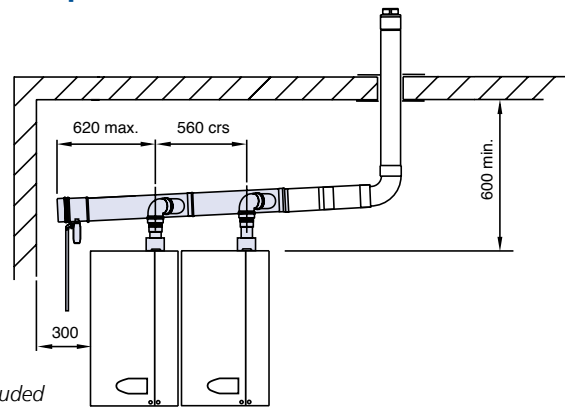

*Shaded items included in header kit*

**Diagram 10 - B23 flue header extension kit  
 for a single boiler - 150mm and 200mm dia.**

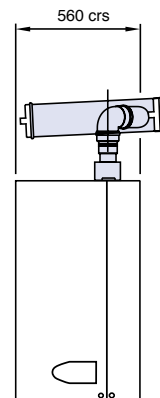

*Shaded items included in header kit*

### Type B23 vertical flue terminal

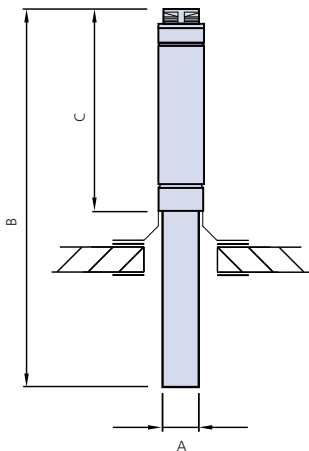

#### Type B23 vertical flue terminal Dimensions (mm)

A	B	C
150	1575	800
200	1600	800

# Flue Design

Fleet Wall Hung Boilers  
Flue Header Systems  
B23 Open Flue

kW Output	Flue Header Dia. (mm)	Max Flue Length (m)	Equivalent Lengths (m)	
			45° Elbow	90° Elbow
80	150	150	3	4
100	150	130	3	4
150	150	100	3	4
200	150	75	3	4
250	150	45	3	4
300	150	32	3	4
	200	110	3	4
350	150	25	3	4
400	200	50	3	4
500	200	25	3	4
	250	110	4	5
600	200	10	3	4
	250	36	4	5

## Flue Headers

The flue header system is designed to connect the boiler flue outlet into the header in the correct position, preventing flue condensate from draining back through the boiler.

Flue headers should be installed with a minimum 3° rise from the boilers towards the flue terminal to allow condensate to run back towards the drain kit.

The air supply for open flue appliances is drawn in from the top of the casing via the space surrounding the flue connection. A circular cage is provided to ensure debris cannot enter the air intake of the boiler combustion system.

From the header system, the flue system should be completed in single wall components through to the flue terminal, which may be terminated horizontally or more usually vertically, dependent on boiler output and flue diameter.

The flue components are manufactured in polypropylene with EPDM joint seals and are not UV stabilised so therefore only suitable for use internally.

Where flue systems must be run or located externally please contact our technical team for further assistance.  
Tel 01202 662500.

## Flue System Condensate Discharge

In addition to the boiler condensate drainage, it is important that the flue system is drained independently, to avoid flue condensate running back through the boiler. This is particularly important where mixed materials are used in the flue system, for external flue runs.

Boiler flue header systems 150mm diameter Boiler models F40W to F100W only		
Item	Diameter (mm)	Part number
Flue header kit 2 boilers – models F40W to F100W	150	562511020
Flue header extension kit 1 boiler – models F40W to F100W	150	562511017
Flue elbow 90° and wall bracket	150	562511022
Flue elbow 90°	150	532511122
Flue elbow 45°	150	532511121
Flue pipe 1000mm long	150	532511134
Flue terminal horizontal or vertical 1570mm long	150	532511145
Flue wall bracket	150	532511033
Flue flat roof flashing	150	532511174
Flue pitched roof flashing 25° to 45°	150	532511178

Boiler flue header systems 200mm diameter Boiler models F40W to F150W		
Item	Diameter (mm)	Part number
Flue header kit 2 boilers - models F40W – F100W	200	562511021
Flue header extension kit 1 boiler - models F40W – F100W	200	562511018
Flue header kit 2 boilers – models F125W – F150W	200	562511019
Flue header extension kit 1 boiler – models F125W – F150W	200	562511016
Flue elbow 90° and wall bracket	200	562511023
Flue elbow 90°	200	532511166
Flue elbow 45°	200	532511167
Flue pipe 1000mm long	200	532511136
Flue terminal horizontal or vertical 1600mm long	200	532511146
Flue wall bracket	200	532511186
Flue flat roof flashing	200	532511175
Flue pitched roof flashing 23° to 30°	200	532511179
Flue pitched roof flashing 31° to 47°	200	532511180
Flue pitched roof flashing 48° to 52°	200	532511181

Boiler flue header system expansion 200mm to 250 mm diameter Boiler models F125W to F150W		
Item	Diameter (mm)	Part number
Flue eccentric expansion fitting	200-250	532511168
Flue elbow 90°	250	532511169
Flue elbow 45°	250	532511171
Flue pipe 1000mm long	250	532511137
Flue pipe 2000mm long	250	532511172
Flue terminal vertical 1600mm long	250	NA



### Customer Service Centre

Hamworthy Heating Limited  
Fleets Corner, Poole,  
Dorset BH17 0HH

Telephone: **0845 450 2865**  
Email: **[sales@hamworthy-heating.com](mailto:sales@hamworthy-heating.com)**  
Web: **[www.hamworthy-heating.com](http://www.hamworthy-heating.com)**

Hamworthy reserves the right to make changes and improvements which may necessitate alteration to the specification without prior notice.

500002562 C

### Hamworthy Heating Accreditations

ISO 9001 Quality Management System  
ISO 14001 Environmental Management System  
OHSAS 18001 Health & Safety Management System

The printed version of this brochure is produced  
using environmentally friendly print solutions  
in partnership with our suppliers

