

Lilliput Dimensions

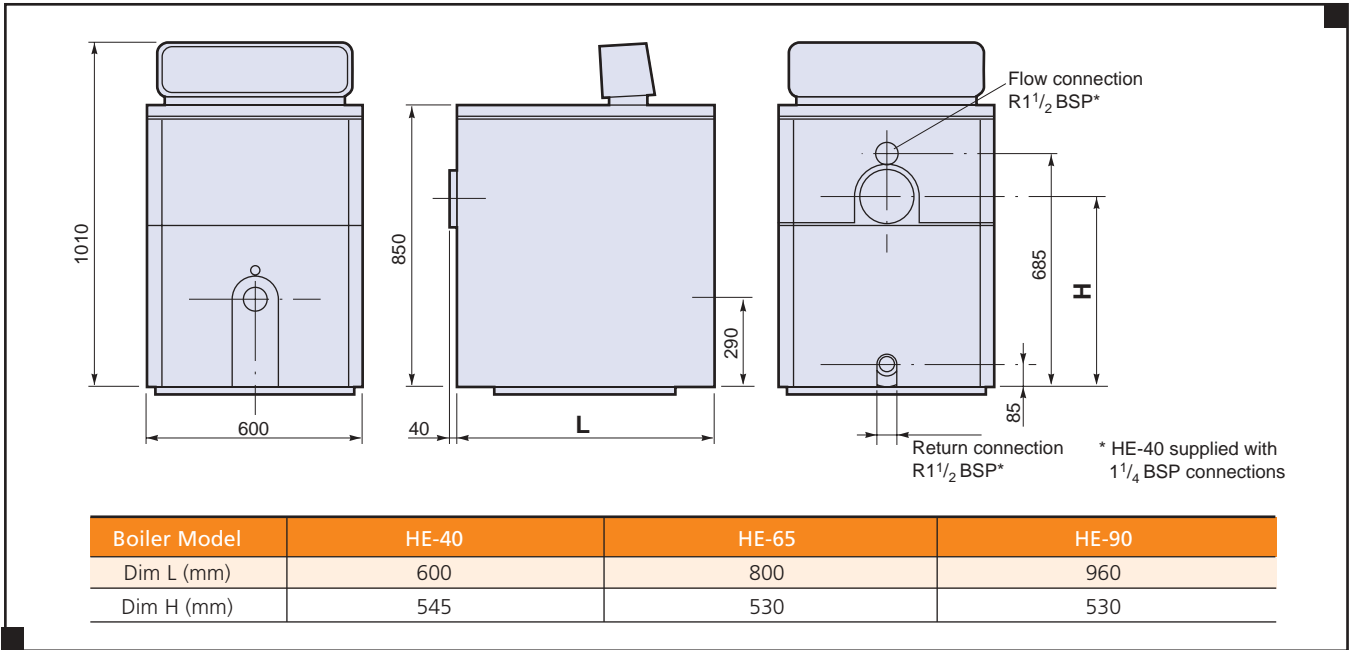

Layout

The Lilliput series must be installed on a level, fire proof plinth, which should be 50mm high (minimum) and capable of supporting the weight of the boiler, pipework and ancillary equipment.

The plinth should end flush with the boiler casing front to prevent interference with the burner oil pipework or gas train and should be at least the width and length of the casing dimensions.

Boiler Clearances

The Lilliput series requires adequate clearances for fuel, flue, water connections and maintenance.

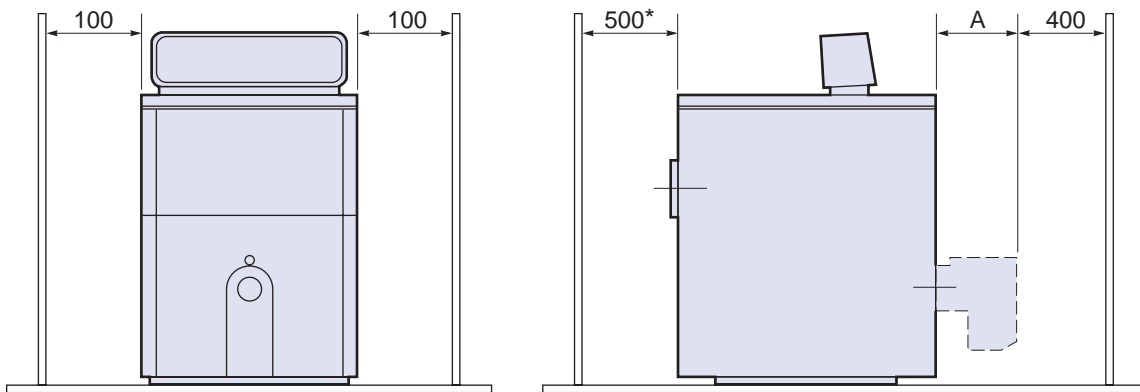

Model	A (mm)				Shipping Weight Dry (kg) Approx.
	Oil		Gas		
	Riello	NuWay	Riello	NuWay	
HE-40	236	206	295	265	172
HE-65	261	206	347	290	235
HE-90	261	325	347	290	298

This dimension is a minimum recommendation permitting access to the rear of the boiler for maintenance. It may not, however, be adequate for the installation of flue bends within the boiler house. Where necessary this dimension must be increased accordingly.

For detailed specification on burner options - contact Hamworthy Heating Technical Applications Team for details, 0845 4502867