

Ferndown Room Sealed Water Heater

Installation, Commissioning and Servicing Instructions

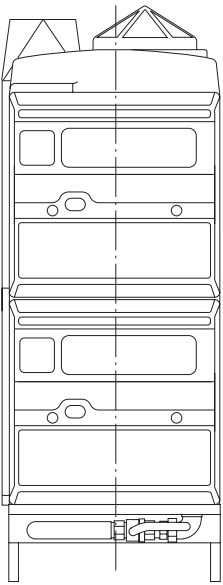

IMPORTANT NOTE

**THESE INSTRUCTIONS MUST BE READ
AND UNDERSTOOD BEFORE INSTALLING,
COMMISSIONING, OPERATING OR
SERVICING EQUIPMENT**

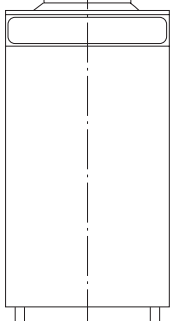
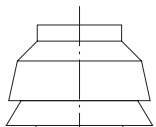
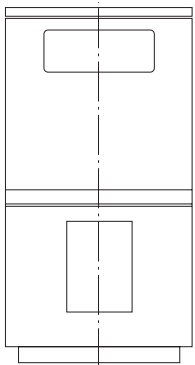

Customer Services

Technical Enquiries



01202 662527/662528

To supplement the detailed technical brochures, technical advice on the application and use of products in the Hamworthy Heating range is available from our technical team in Poole and our accredited agents.

Site Assembly



01202 662555

Hamworthy offer a service of site assembly for many of our products in instances where plant room area is restricted. Using our trained staff we offer a higher quality of build and assurance of a boiler built and tested by the manufacturer.

Commissioning



01202 662555

Commissioning of equipment by our own engineers, accredited agents or specialist sub – contractors will ensure the equipment is operating safely and efficiently.

Maintenance Agreements



01202 662555

Regular routine servicing of equipment by Hamworthy service engineers inspects the safety and integrity of the plant, reducing the risk of failure and improving performance and efficiency. Maintenance agreements enable our customers to plan and budget more efficiently.

Breakdown service, repair, replacement



01202 662555

Hamworthy provide a rapid response breakdown, repair or replacement service through head office at Poole and accredited agents throughout the UK.

Spare Parts



01202 662525

A comprehensive spare parts service is operated from our factory in Poole, providing replacement parts for both current and discontinued products. Delivery of parts and components is normally from stock within seven days. However, a next day delivery service is available for breakdowns and emergencies.

Ferndown Room Sealed Water Heater

Installation, Commissioning and Servicing Instructions

NOTE: THESE INSTRUCTIONS SHOULD BE READ AND UNDERSTOOD BEFORE ATTEMPTING TO INSTALL, COMMISSION OR OPERATE THIS UNIT

THE FERNDOWN WATER HEATER IS INTENDED FOR USE AS A COMMERCIAL APPLIANCE & CAN BE OPERATED AS EITHER ROOM SEALED OR OPEN FLUE.

THIS APPLIANCE IS FOR USE ON GROUP H NATURAL GAS (2ND FAMILY)_{I_{2H}} OR LPG-PROPANE (3RD FAMILY)_{I_{3P}}. PLEASE ENSURE RELEVANT INFORMATION REQUIRED WITHIN DOCUMENT IS FOUND RELATING TO SPECIFIC GAS TO BE FIRED BEFORE FIRING APPLIANCE.

THIS APPLIANCE COMPLIES WITH ALL RELEVANT EUROPEAN DIRECTIVES.
EC TYPE CERTIFICATE No. (GAD) EC 87/02/27, (BED) BE-87/01/02
PRODUCT IDENTIFICATION No 87BN27

**PUBLICATION NO. 500001111
ISSUE 'C'
May 2003**

CONTENTS

	PAGE
INDEX	iii
1.0 INTRODUCTION	1
2.0 TECHNICAL DATA	1
3.0 GENERAL REQUIREMENTS	5
3.1 Related Documents	
3.2 Feed Water Quality	
3.3 Adequate Water Flow	
3.4 Time Clock Control	
3.5 Minimum System Water Pressure	
4.0 LOCATION	6
5.0 GAS SUPPLY	6
5.1 Service Pipes	
5.2 Meters	
5.3 Gas Supply Pipes	
5.4 Boosted Supplies	
5.5 Boiler House Control Valve	
5.6 Boiler Gas System Leak Check	
6.0 FLUE SYSTEM	6
6.1 General Requirements	
6.2 Condense Drain	
6.3 Design Waste Gas Volume and Temperature	
6.4 Maximum Length of Flue Duct	
6.5 Disconnection	
6.6 Flue Discharge	
6.7 Surface Temperatures	
6.8 Flue System Location	
7.0 AIR SUPPLY	13
7.1 Air Supply by Natural Ventilation (Open Flue)	
7.2 Air Supply by Natural Ventilation (Room Sealed)	
7.3 Air Supply by Mechanical Ventilation (Open Flue)	
8.0 WATER CIRCULATION SYSTEM	13
8.1 General	
8.2 Pressure Relief Valve (Safety Valve)	
8.3 Open Vent Pipe and Cold Feed Pipe	
8.4 Altitude Gauge (Water Pressure Gauge)	
8.5 Thermometer	
8.6 Drain Valves	
8.7 Circulating Pump	
8.8 Controls	
8.9 Unvented Pressurised Systems	
8.10 Boiler Control Scheme	

	PAGE
9.0 ELECTRICAL SUPPLY	15
9.1 Electrical Supply Connections	
9.2 Indication Signals & Volt Free Contacts	
9.3 Cable Installation	
10.0 BOILER ASSEMBLY AND INSTALLATION.....	15
10.1 General	
10.2 Assembling the Appliance	
10.3 Connection of the Boiler Module to the Flue System	
10.4 Water Connections	
10.5 Condense Trap Connection	
10.6 Gas Connection	
10.7 Fitting the Front Cover and Panels	
11.0 COMMISSIONING AND TESTING	21
11.1 Electrical Installation	
11.2 Gas Installation	
11.3 Water Circulation System	
11.4 Commissioning the Boiler	
11.5 Appliance Checks Prior to Lighting	
11.6 External Controls	
11.7 User's Instructions	
12.0 FAULT FINDING.....	25
12.1 1 Safety Features Summary	
12.1.2 Fault Finding Procedures	
12.1.3 Possible Causes of Boiler Lockout	
13.0 SERVICING.....	30
14.0 REPLACEMENT OF FAILED COMPONENTS.....	31
15.0 RECOMMENDED SPARES.....	33
APPENDIX 'A' - INFORMATION RELATING TO PROPANE FIRING.....	34
FIGURES	PAGE
Figure 1.1 Appliance Installation.....	2
Figure 2.1 Appliance Dimensions & Clearances	3
Figure 2.2 Performance & General Data Information.....	4
Figure 6.1.1 Horizontal Balanced Flue (C13).....	8
Figure 6.1.2 Vertical Balanced Flue (C33).....	9
Figure 6.1.3 Separate Intake & Discharge Ducts (C53).....	10
Figure 6.1.4 Intake from Ventilated Plant Room & Discharge via Horizontal / Vertical Flue (C53).....	11
Figure 6.1.5 Flue Terminal Positions	12
Figure 6.4 Flue Resistance	7
Figure 7.2 Minimum Air Vent Requirements – Compartment Installation.....	13
Figure 7.3 Mechanical Ventilation Flow Rates.....	13
Figure 8.10 Site Wiring Diagram.....	16
Figure 9.1.1 Wiring Schematic (Auxiliary Control Panel).....	16
Figure 9.1.2 Wiring Schematic (Main Control Panel).....	17
Figure 10.3.1.1 Connection of Flue System (Concentric Ducts Horizontal).....	18
Figure 10.3.1.2 Flue Support Cradle.....	18
Figure 10.3.2 Connection of Flue System (Concentric Ducts Vertical).....	19
Figure 10.3.3 Connection of Flue System (Separate Ducts).....	19

	PAGE
Figure 11.1 Appliance Layout.....	22
Figure 11.2 Gas Valve / Venturi Layout.....	23
Figure 11.3.1 Thermostatic Mixing Valve Settings.....	21
Figure 11.5 Instrumentation Set Up for Initial Lighting and Offset Adjustment.	23
Figure 11.5.4 Fan Speed Vs Boiler Input	25
Figure 12.1 General Fault Finding.....	26
Figure 12.2 General Fault Finding.....	27
Figure 12.3 General Fault Finding.....	28
Figure 12.4 General Fault Finding.....	29
Figure 13.2 Position of Probes on Burner Assembly.....	30
Figure 2.2 Performance & General Data Information – LPG Propane.....	34

1.0 INTRODUCTION

1.1 This appliance must be installed by a competent person holding 'CORGI' registration or equivalent. All installations **MUST** conform to the relevant Gas Safety and Building Regulations. Health & Safety requirements must also be taken into account when installing any equipment. Failure to comply with the above may lead to prosecution.

1.2 The appliance is intended for use on Group H Natural Gas (2nd Family) and LPG-Propane (3rd Family). The information relating to propane firing is to be found in Appendix 'A'. The appliance **MUST NOT** use gas other than that for which it was designed and adjusted.

1.3 The Ferndown is a high efficiency, gas fired, fully modulating, room sealed instantaneous water heater with the included option of connecting to and supplying central heating systems. For performance data refer to Figure 2.2.

1.3.1 The burner fitted to the Ferndown is of the fan assisted pre-mix type. Operation is initiated by a full sequence ignition control that incorporates a Hot Surface Ignition system and rectification supervision of the flame across the range of outputs.

1.3.2 The appliance is designed for direct connection to a room sealed or conventional flue system - **HHL supply**. The Technical Data for the various flue arrangements is given in **Section 6**. No draught diverter is fitted to the boiler nor is a fixed diverter required in the flue system. However a draught stabiliser is recommended for some installations.

1.3.3 The Ferndown is intended as a single stand alone unit not suitable for modular application supplying domestic hot water and central heating within Commercial / Industrial premises only.

1.3.4 The Ferndown is fitted with an integral circulator pump suitably sized to ensure that minimum water rates are maintained through the low water content primary heat exchanger.

1.3.5 The Ferndown uses a brazed plate heat exchanger for DHW generation. To ensure continuous and reliable operation, refer to section 3.2.2 regarding water conditioning.

1.4 The Ferndown is suitable for direct connection to domestic hot water supplies and to fully pumped un-vented (pressurised) heating systems. Care must be taken to ensure all extra safety requirements are satisfied and that the relevant interlocks will shut the Ferndown off should a high or low pressure fault occur. The Ferndown primary loop circuit is fitted with a pressure switch, factory set at 0.5 bar which shuts the

appliance down should the primary water pressure fall below the factory set threshold.

Note: The Ferndown is not suitable for direct connection to gravity circulation systems.

When connecting to pressurised central heating circuits the pressurisation unit must also incorporate a low level water switch which protects the water pumps, and will directly or indirectly shut down the boiler plant should a low water condition occur. Consideration should also be given to the maximum working pressure of the appliance as given in Section 2: TECHNICAL DATA. Consult Hamworthy Heating Technical Department for help or assistance if in doubt.

1.5 N.B. For space heating applications, the Ferndown has a constant flow (non-adjustable) temperature of 80°C, therefore thermostatic radiator valves should be used to control the temperature.

2.0 TECHNICAL DATA

2.1 The Ferndown data plate giving details of model and serial number is located on the inner boiler casing.

Overall dimensions are shown in Figure 2.1.

2.2 General Information and Technical Data relating to Natural Gas is shown in Figure 2.2.

Technical data relating to propane firing can be found in Appendix 'A'.

2.3 Screw threads: All screw threads used in the Ferndown range of boilers conform to the following:-

ISO 7/1 or **ISO 228/1** for pipe threads where applicable.
ISO 262 for all general screw threads.

Figure 1.1 Appliance Installation (Typical)

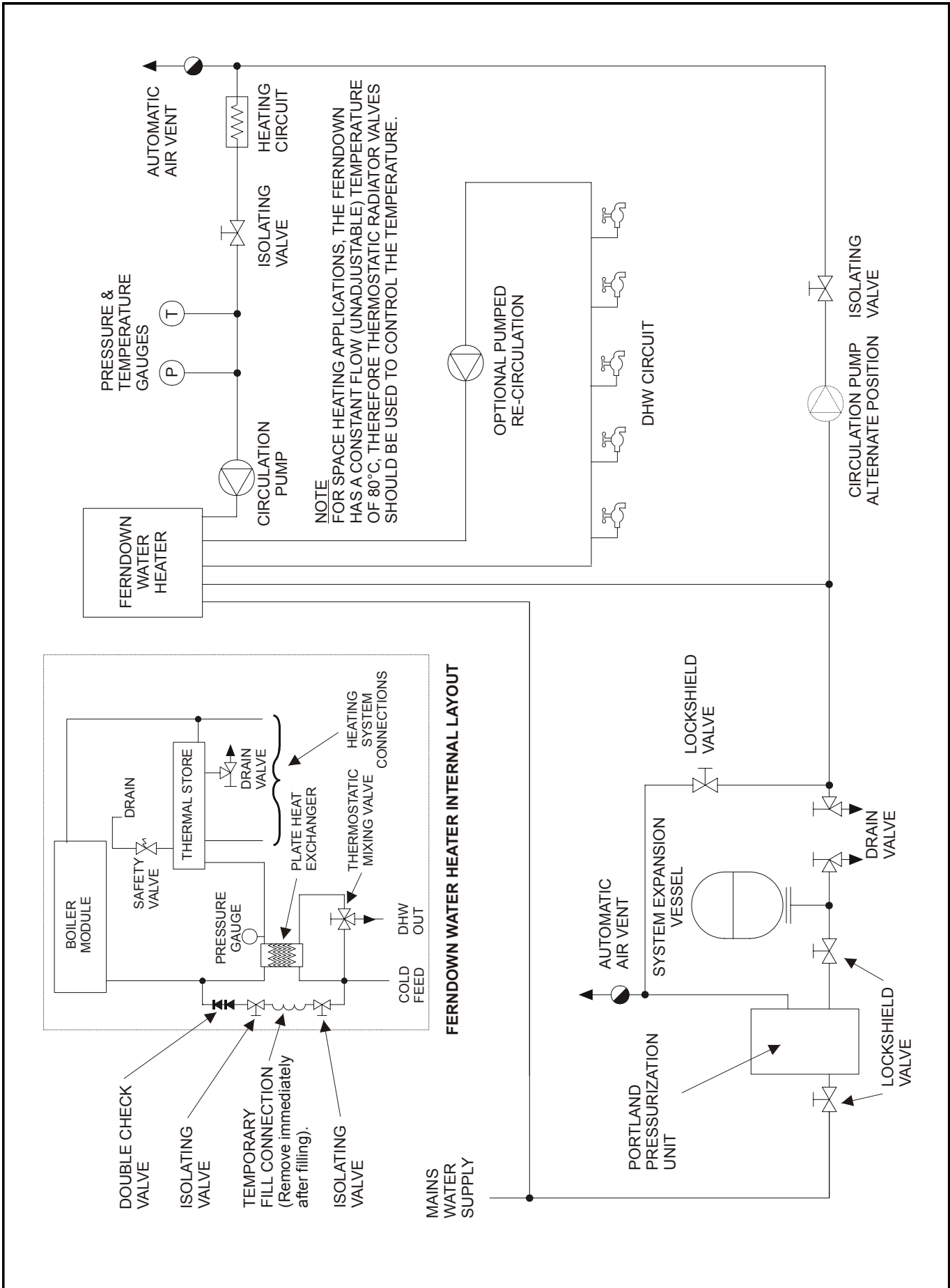

Figure 2.1 Appliance Dimensions/Clearances

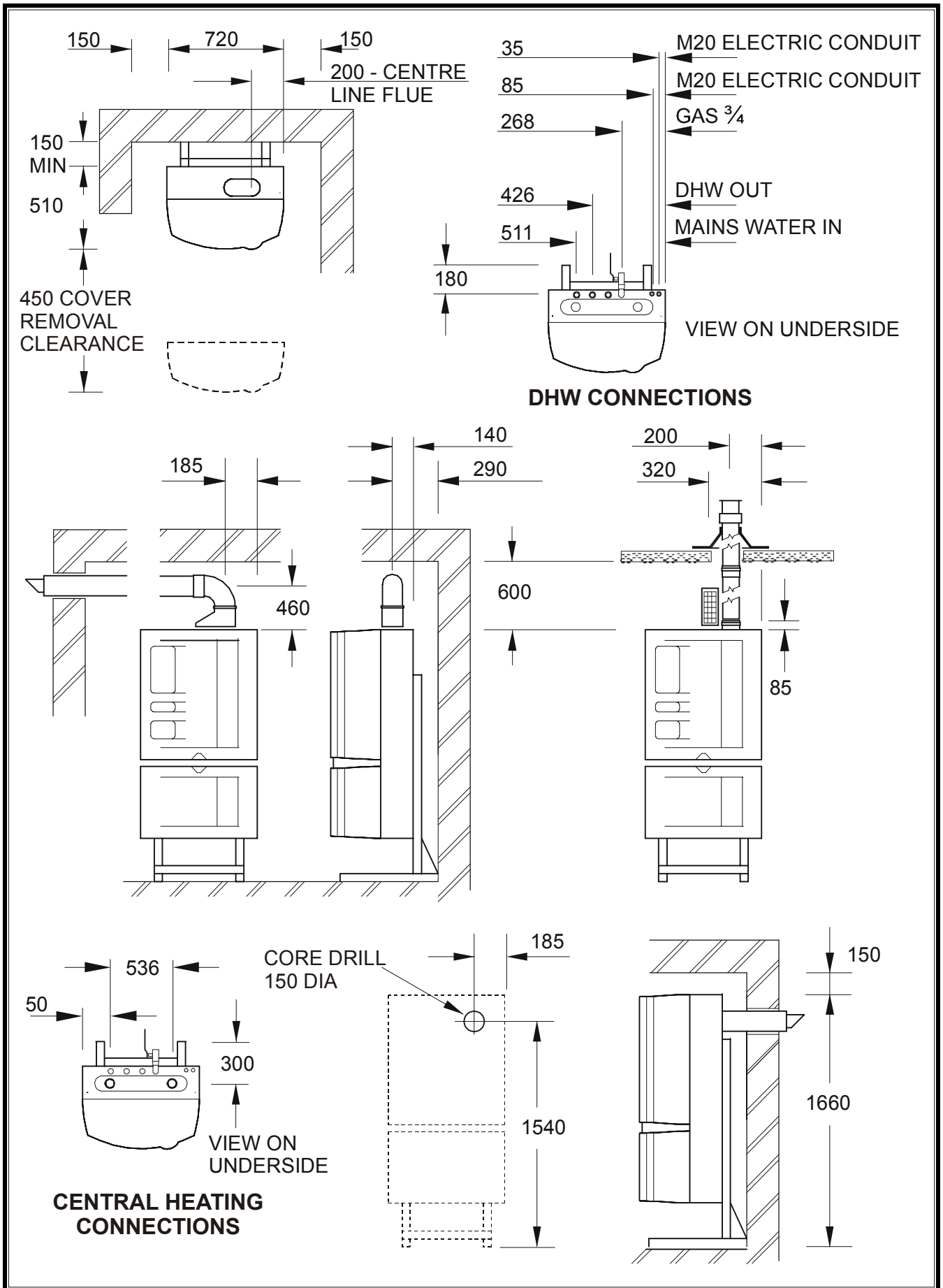

Figure 2.2 Performance and General Data Information – Natural Gas

GENERAL DATA		FERNDOWN
Boiler Input kW (Gross)	- maximum	77.7
Boiler Input kW (Nett)	- maximum	70.0
Boiler Input kW (Gross)	- minimum	15.5
Boiler Input kW (Nett)	- minimum	14.0
Space Heating Output kW	-minimum	13.6
Space Heating Output kW	- maximum	63.7
DHW output (30°C rise) l/min		30.4 (1825 l/h)
DHW output (44°C rise) l/min		20.7 (1244 l/h)
FLUE DATA		
Nominal Flue Dia. mm		Single pipe = 100, dual concentric = 80/125 or 100/150
Approx. Flue Gas Temperature	°C	140
Approx. Flue Gas Vol. @ 9.0 – 9.5% CO ₂ & NTP(Dry)	m ³ /h	114
Nox corrected (daf) mg/kWh [ppm]		44 [25]
GAS DATA		
Nominal Gas Inlet Press.	mbar	20
Maximum Gas Inlet Press.	mbar	25
Minimum Gas Inlet Press.	mbar	12.5
Gas Flow Rate -maximum	m ³ /h	7.4
Gas Inlet Connection Pipe Thread Size		Rp ³ / ₄ "
WATER DATA		
Water Connections DHW		22mm Copper
Water Connections DHW re-circulation		³ / ₄ " BSP
Water Connections Central Heating (F&R)		1 ¹ / ₄ " BSPT
Maximum Water Pressure (Primary)	bar g	2.5
Maximum Water Pressure (Secondary)	bar g	7.0
Circuit Resistance (Primary)	bar	0
Circuit Resistance (Secondary)	bar	0.5 @ 20 l/min
Water Content (not including pipework)	litres	34.0
Shipping Weight (excluding flue)	kg	165
ELECTRICAL DATA		
Normal Supply Voltage		230V AC 50Hz (300W max.)
Start and Run Current		< 1A

NOTE ! Boiler outputs based on European test conditions – the maximum δT for the Ferndown boiler is 15°C. Flue gas volumes are based on a flue gas temperature of 0°C at 1013mbar

3.0 GENERAL REQUIREMENTS

3.1 Related Documents.

Gas Safety Installations and Use Regulations 1994-(As amended). It is law that all gas appliances are installed by competent persons, in accordance with the above regulations. Failure to install appliances correctly could lead to prosecution. It is in your own interest, and that of safety, to ensure that this law is complied with.

The installation of the Ferndown **MUST** be in accordance with the relevant requirements of the Gas Safety Regulations, Building Regulations, IEE Regulations and the bylaws of the local water undertaking.

The installation should also be in accordance with any relevant requirements of the local gas region and local authority and the relevant recommendations of the following documents :-

British Standards

- BS 5440: Part 1:** Specification for installation of flues.
Part 2: Specification for installation of ventilation for gas appliances.
BS 6644: Installation of Gas Fired Hot Water Boilers - 60 kW to 2MW.
BS 6700: Design, installation, testing and maintenance of services supplying water for domestic use.
BS 6880:Part 1, 2 & 3: Code of practice for low temperature hot water heating systems of output greater than 45 kW.
BS 7074:Part 1: Application, selection and installation of expansion vessels and ancillary equipment for sealed water systems. **Part 2:** Code of practice for low and medium temperature hot water systems.

CP 342: Centralised hot water supply. Part 2: Buildings other than individual dwellings.

I. Gas E. Publications

- IGE/UP/1** Soundness testing and purging of industrial and commercial gas installations.
IGE/UP/1A Soundness testing and direct purging of small low pressure industrial and commercial natural gas installations.
IGE/UP/2 Gas installation pipework, boosters and compressors in industrial and commercial premises.
IGE/UP/10 Installation of gas appliances in industrial and commercial premises Pt 1 flued appliances.

CIBSE Publications:- "CIBSE Guide"

It is impractical in this document to specify all relevant information, but the following extracts from the above references are emphasised since failure to comply with these requirements will almost certainly result in an unsatisfactory installation.

3.2 Feed Water Quality

3.2.1 Primary Water

If the boiler feed water has a high degree of hardness, it is recommended that the water be treated to prevent precipitation of scale or sludge in the boiler water passageways. Details of additives can be obtained from any reliable manufacturer of water treatment products or the local water authority.

It should be noted however, that even if the boiler water is of average hardness, not requiring treatment, subsequent draining of the system for repair or constant make-up water due to an undetected leak will cause additional deposits and gradual build-up of scale. It is essential therefore, that leaks are attended to promptly and draining is kept to an absolute minimum.

It is recommended that the system be flushed out at least twice before any water treatment is added. If any doubt exists regarding the internal cleanliness of an old system, consideration should be given to the fitting of a coarse filter in the return pipework to the boilers.

3.2.2 Domestic Water

To ensure the continued and reliable operation of this product, a traditional salt exchange water softener must be suitably sized and fitted upstream of the cold water inlet unless otherwise advised by the local water authority. Failure to comply with this requirement will result in the invalidation of the product warranty.

3.3 Adequate Water Flow

The Ferndown is fitted with an integral circulator pump suitably sized to ensure that minimum water rates are maintained through the low water content primary heat exchanger.

When connecting to central heating systems care should be taken in the initial design and layout having due regard for adequate water flow through the appliance and the influence of the system controls.

Note: When connecting to a central heating system operating at 80/70°C the effect of the Ferndown on system pressure losses can be considered negligible as the integral circulator pump is sized to overcome the resistance of the heat exchanger and therefore does not add to or reduce system resistance.

3.4 Time Clock Control

The integral primary loop circulating pump is provided with a five minute over-run after the boiler has ceased firing to prevent localised overheating and progressive calcium deposition.

NOTE! Time clocks **must** not interrupt live, neutral or earth connections, see **Section 9.0: ELECTRICAL SUPPLY** for details. See Figures 8.10, 9.1.1 and 9.1.2 for wiring details.

3.5 Minimum System Water Pressure

It is recommended that a minimum cold fill pressure of 1 bar is set during the initial cold fill.

When connecting the appliance to central heating systems, reference should be made to **Section 8.9**.

4.0 LOCATION

4.1 (See Figures 2.1. & 2.2. for dimensions /clearances and weights.) The location chosen for the Ferndown **MUST** permit the provision of a satisfactory flue system and an adequate air supply. The location must also provide adequate space for servicing and air circulation around the appliance. This includes any electrical trunking laid along the floor and to the appliance. The must be installed on a non combustible flat and level surface capable of supporting the weight of the appliance when full of water and any additional ancillary equipment.

Any combustible material adjacent to the Ferndown and the flue system must be so placed or shielded to ensure that its temperature does not exceed 65° C.

Further details regarding appliance location are given in **BS 6644. & BS 5440 part 2**.

5.0 GAS SUPPLY

5.1 Service Pipes

The local gas region must be consulted at the installation planning stage in order to establish the availability of an adequate supply of gas. An existing service pipe must not be used without prior consultation with the local gas region.

5.2 Meters

A new gas meter will be connected to the service pipe by the local gas region, or a local gas region contractor. An existing meter should be checked, preferably by the gas region, to ensure that it is adequate to deal with the rate of gas supply required.

5.3 Gas Supply Pipes

Supply pipes must be fitted in accordance with **BS 6891 or IGE/UP/2**. Pipework from the meter to the boiler must be of adequate size. Do not use pipes of a smaller size than the boiler gas connection. The complete installation must be purged and tested for soundness as described in **BS 6891 or IGE/UP/1 & IGE/UP/1A** as appropriate.

5.4 Boosted Supplies

Where it is necessary to employ a gas pressure booster, the controls must include a low pressure cut-off switch at the booster inlet. The local gas region must be consulted before a gas pressure booster is fitted.

5.5 Boiler House Control Valve

A manual valve for boiler house isolation shall be fitted in the gas supply line. It shall be clearly identified and readily accessible for operation, preferably by an exit.

5.6 Boiler Gas System Leak Check

The incoming mains gas supply must be capable of supplying gas to the appliance at the required pressure and volume, under all firing conditions. An isolating valve and union is supplied for each appliance and is accessible at the bottom of the casing.

Although the boiler module receives a gas leak check prior to leaving the factory, transport and installation may cause disturbance to unions, fittings and assemblies etc. During commissioning, a further test for soundness should be carried out on the boiler gas pipe-work and components.

Note:- Main Gas Supply Pressure -
Nat Gas - 20mbar
Propane - 37mbar

6.0 FLUE SYSTEM

Detailed recommendations for flue systems are given in **BS 6644, BS 5440, IGE/UP/10**.

All flue discharges for plant exceeding 150kW output must comply with the Third edition of the 1956 Clean Air Act Memorandum.

The following notes are intended to give general guidance only.

For allowable terminal positions refer to figure 6.1.5.

6.1 Flue System General Requirements

The Hamworthy Ferndown is designed for use with the following flue systems supplied by Hamworthy - see Figures 6.1.1, 6.1.2, 6.1.3 & 6.1.4:

80/125mm concentric room sealed, balanced flue system for rear through the wall discharge.

100/150mm concentric, room sealed, balanced flue system for remote discharge, horizontal or vertical – maximum length 7m.

100mm separate air and flue ducts, room sealed, balanced flue system for remote discharge – maximum length 10m.

100mm flue duct, for connection to an open flue (chimney) system – maximum length 10m.

Flue systems should be designed with reference to **BS 5440 part 1, IGE/UP/10**, and **Third Edition of the 1956 Clean Air Act Memorandum**.

Flue installations can be configured to suit a number of applications, see Figures 6.1.1, 6.1.2, 6.1.3 & 6.1.4: but must comply with one of the following options:

Room Sealed.

Type C13: Horizontal balanced flue. – Fig 6.1.1.

Type C33: Vertical balanced flue. – Fig 6.1.2.

Type C53: Separate intake and discharge ducts terminating in different pressure zones. – Fig 6.1.3.

Open Flue.

Type B23: Intake from ventilated plant room and discharge via horizontal/vertical flue. – Fig 6.1.4.

WARNING

The Sherborne boiler is a High Efficiency/Condensing boiler and in certain conditions 'plumbing' will be visible from the flue terminal. Should plumbing be a concern, the flue system design should discharge at high level.

Care should be taken to ensure that the flue is installed such that any condensation is continuously drained back to the boiler or any resultant low points in the flue system. Horizontal flue runs should be kept to a minimum and must be inclined at 2° upwards in the direction of the exhaust gas flow. All joints should be such that any condensation is directed back down the slope.

6.2 Condense Drain

The boiler module is provided with a condense drain suitable for connection to 22mm plastic waste pipe (not supplied), which must be connected to a tundish (not supplied).

Discharge piping from a tundish should be of a synthetic material due to the mild acidity of the condensate (pH 3-5), with all discharge piping having a minimum fall of 30mm/m away from the boiler. Consideration should be given to possible freezing of condense water traps and pipework. This must be avoided at all times by routing pipework within the building, where possible.

6.3 Design Waste Gas Volume and Temperature

6.4 Maximum Length of Flue Duct.

For Ferndown installations the maximum allowable linear equivalent length of straight smooth bore tube for both (air supply and flue discharge) twin duct, and concentric systems is approximately 10m and 7m respectively. This dimension relates to the distance between the boiler and the discharge terminal. The table below nominates the equivalent length of flue tube. Components can be combined in any order provided that the total equivalent length of flue does not exceed the maximum. **Note:** if the maximum stated lengths of flue are exceeded the boiler will not achieve maximum output.

Figure 6.4 Flue Resistance

Equivalent tube lengths.	
Component	Length m
Straight tube ø100mm per m	1
45° bend ø100mm	2.25
90° bend ø100mm	4.10
Concentric straight tube ø80/125mm per m	1
Concentric straight tube ø100/150mm per m	1
Concentric 45° bend ø100/150mm	1.30
Concentric 90° bend ø100/150mm	2.20

6.5 Disconnection

Each Ferndown is fitted with a telescopic appliance connector, enabling the boiler to be disconnected from the flue system.

NOTE! The flue system must be self supporting and not present a risk to people in or around the building. See **Section 13: SERVICING** for further information.

6.6 Flue Discharge

The flue system must ensure safe and efficient operation of the Ferndown to which it is attached, protect the combustion process from wind effects and disperse the products of combustion to the external air.

The flue must terminate in a freely exposed position and be so situated as to prevent the products of combustion entering any opening in a building in accordance with **BS 5440 part 1, IGE/UP/10**.

When the application requires the flue discharge to terminate below 2 m above ground level, the use of a terminal guard is required.

Figure 6.1.1. - Horizontal Balanced Flue

Flue type C13

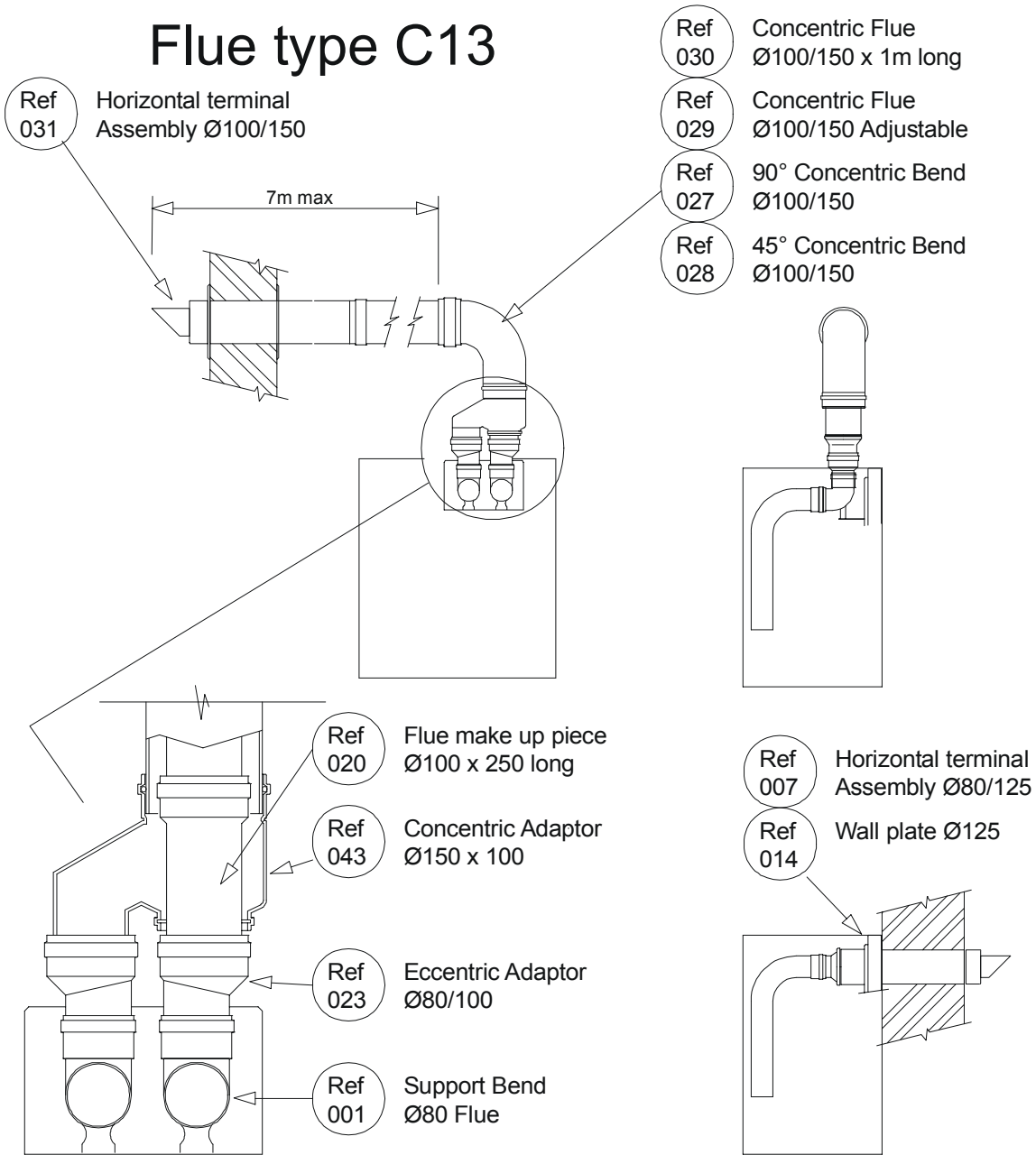

Enlarged detail showing cut section through concentric adaptor

Note: If the terminal is fitted vertically within 2m of areas accessible to people an appropriate terminal guard having a minimum dimension of 250 x 250 x 220 should be fitted.

Figure 6.1.2. - Vertical Balanced Flue

Flue type C33

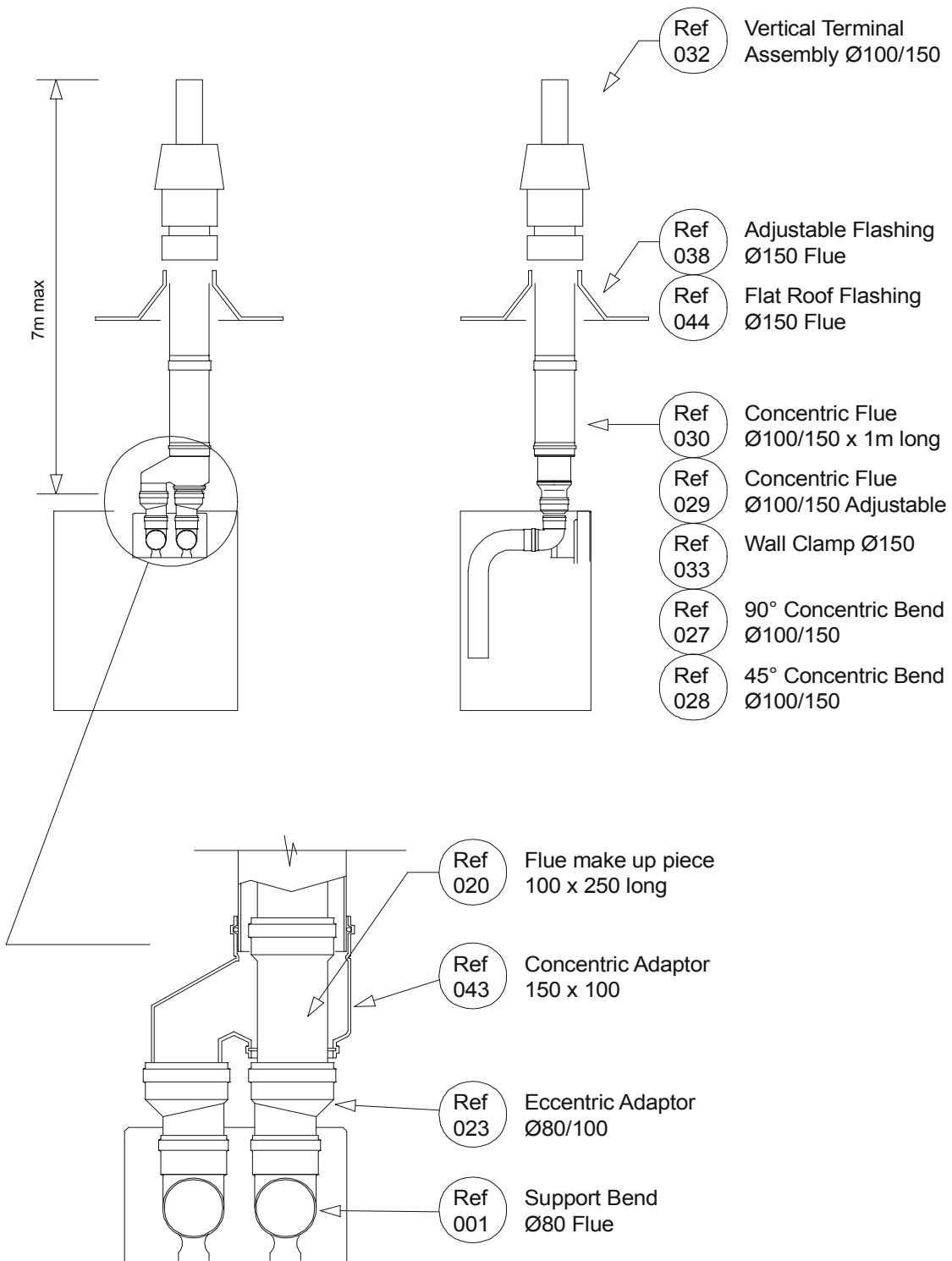

Enlarged detail showing cut section through concentric adaptor

Figure 6.1.3. - Separate Intake and Discharge Ducts

Flue type C53

- Ref 020 Single Flue 250 long Ø100
- Ref 021 Single Flue 500 long Ø100
- Ref 022 Single Flue 1000 long Ø100
- Ref 018 90° Bend 1000 long Ø100
- Ref 019 45° Bend 1000 long Ø100

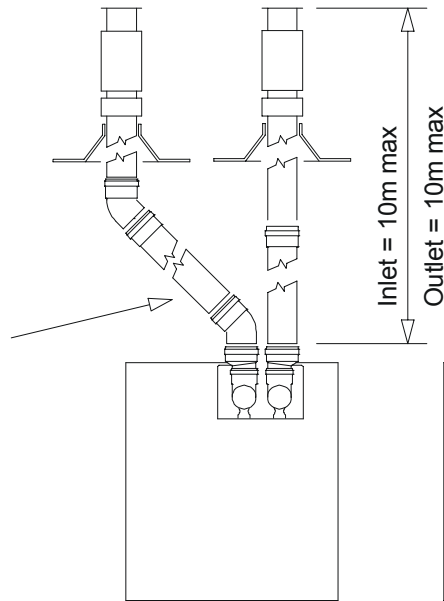

- Ref 026 Vertical terminal Ø100 Flue
- Ref 039 Flat Roof Flashing Ø100 flue
- Ref 040 Adjustable Flashing Ø100 flue
- Ref 017 Wall Clamp Ø100
- Ref 023 Eccentric Adaptor Ø80/100
- Ref 001 Support Bend Ø80 Flue

- Ref 017 Wall Clamp Ø100
- Ref 020 Single Flue 250 long Ø100
- Ref 021 Single Flue 500 long Ø100
- Ref 022 Single Flue 1000 long Ø100
- Ref 018 90° Bend 1000 long Ø100
- Ref 019 45° Bend 1000 long Ø100

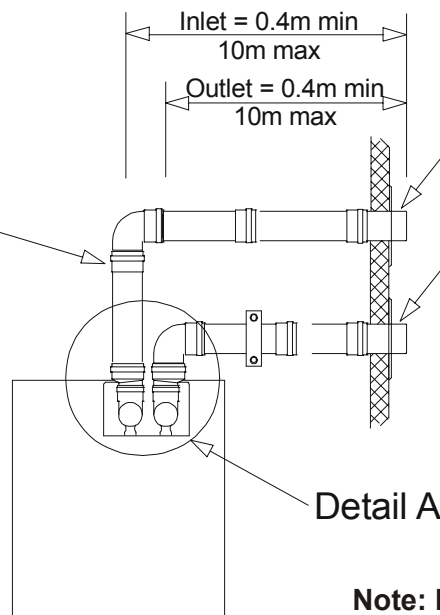

- Ref 024 Horizontal Inlet Terminal Ø100
- Ref 025 Horizontal Flue Terminal Ø100

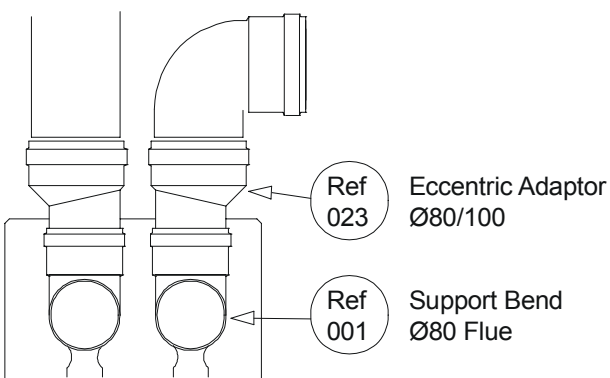

Enlarged detail A

Note: If the flue terminal is fitted vertically within 2m of areas accessible to people an appropriate terminal guard having a minimum dimension of 250 x 250 x 220 should be fitted.

Reference to BS5440 should be made for determination of acceptable terminal location.

Terminals for the supply of combustion air and for the evacuation of combustion products must not be installed on opposite walls of a building.

Figure 6.1.4. - Intake from Ventilated Plant Room and Discharge via Horizontal/Vertical Flue

Flue type B23

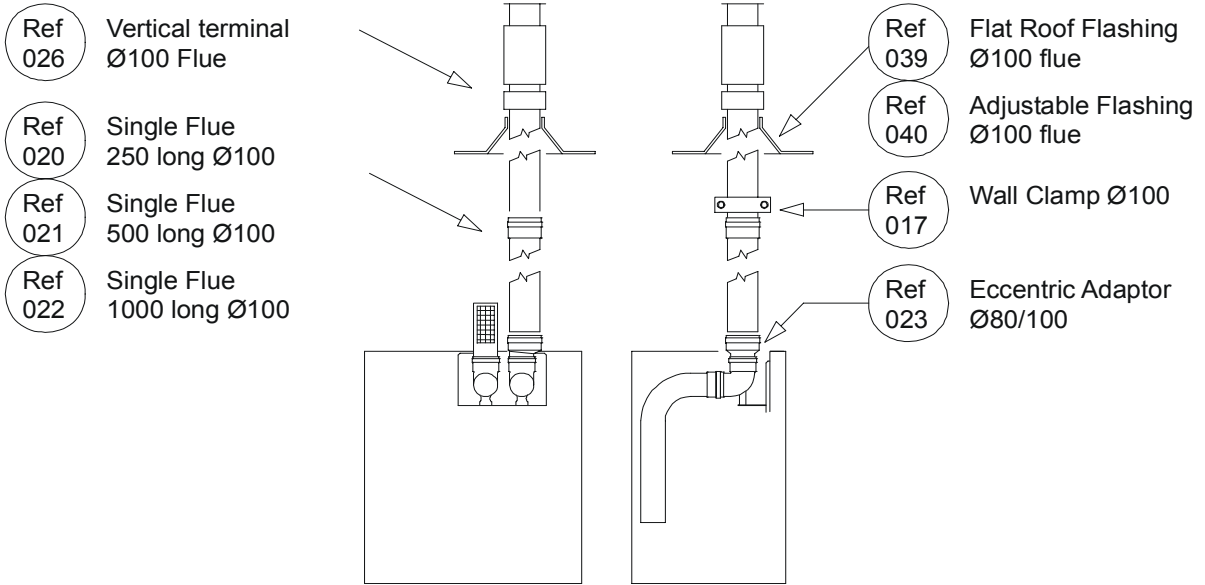

Note: If installing a horizontal flue terminal that is fitted vertically within 2m of areas accessible to people an appropriate terminal guard having a minimum dimension of 250 x 250 x 150 should be fitted.

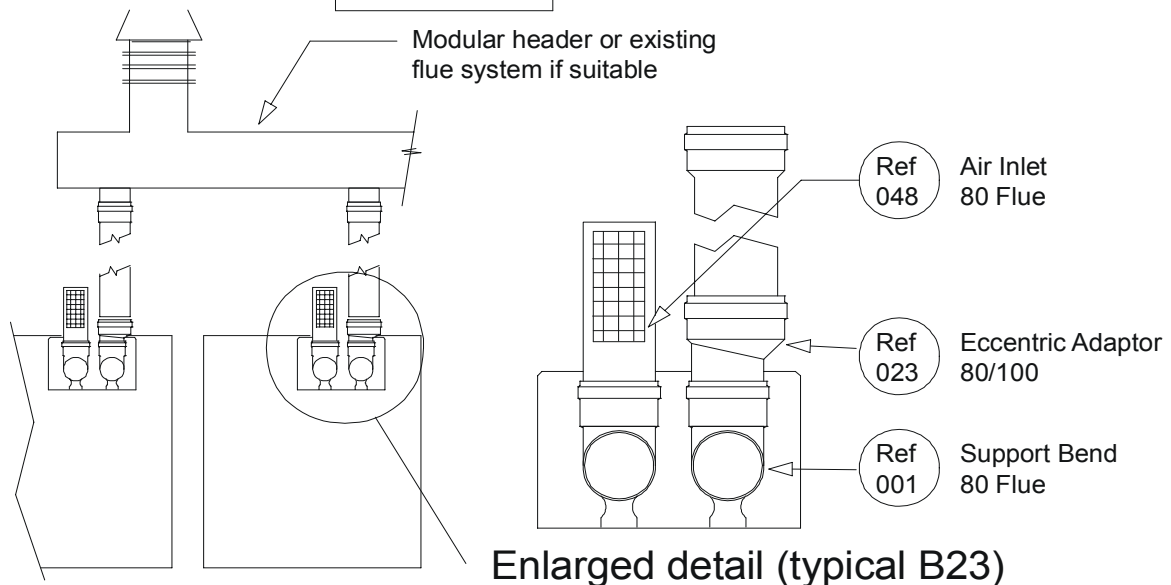
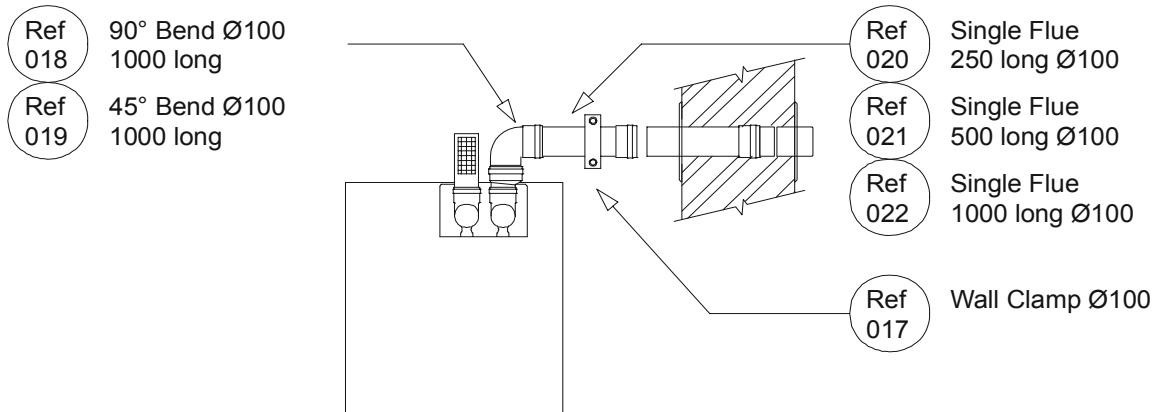
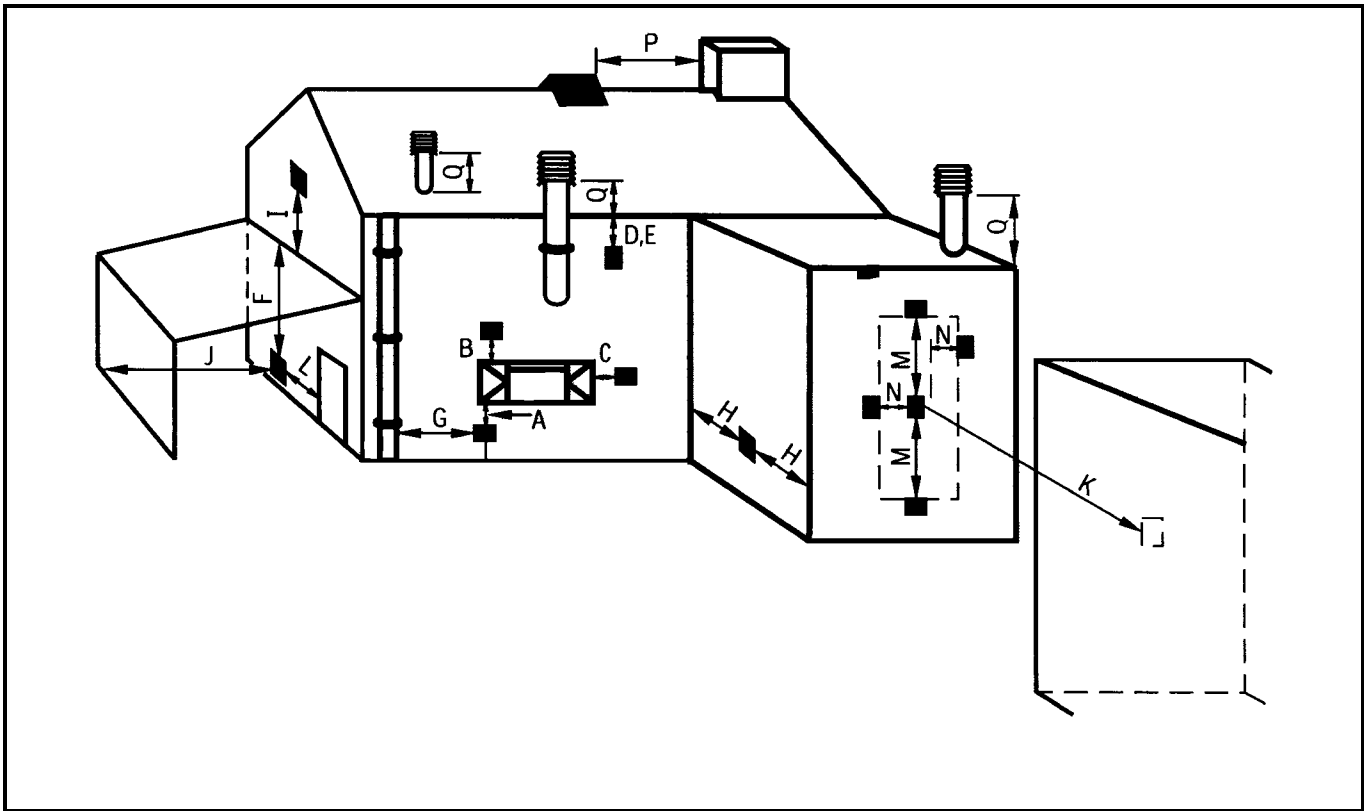

Figure 6.1.5. - Flue Terminal Positions



Dimensions	Terminal Position	Balanced Flue Room Sealed	Open Flue
A	Directly below an opening, air brick, opening window etc	300	300
B	Above an opening, air brick, opening window etc	300	300
C	Horizontally to an opening, air brick, opening window etc	300	300
D	Below gutters, soil pipes or drain pipes	75	75
E	Below eaves	200	200
F	Below balconies or car port roof	200	200
G	From a vertical drain pipe or soil pipe	150	150
H	From an internal or external corner	300	200
I	Above ground roof or balcony level	300	300
J	From a surface facing the terminal	600	600
K	From a terminal facing the terminal	1200	1200
L	From an opening in the car port (e.g. door, window) into the dwelling	1200	1200
M	Vertically from a terminal on the same wall	1500	1500
N	Horizontally from a terminal on the same wall	300	300
O	From the wall on which the terminal is mounted	N/A	50
P	From a vertical structure on the roof	N/A	N/A
Q	Above intersection with roof	N/A	150

Note: The above values represent minimum required dimensions.

6.7 Surface Temperatures

Combustible materials in the vicinity of the Ferndown and flue shall not exceed 65°C during boiler operation. The flue shall not be closer than 50mm to any combustible material, except where it passes through such material with a non-combustible sleeve when the air gap may not be less than 25mm.

6.8 Flue System Location

The flue system must not be placed or fitted where there is undue risk of accidental damage to the flue pipe or undue danger to persons in the vicinity. Check that the flue is clear from any obstruction.

7.0 AIR SUPPLY

Detailed recommendations for air supply and ventilation requirements are given in **BS 6644**, and **BS 5440:Part 2**. The following notes are intended to give general guidance. In all cases there must be provision for an adequate supply of air for both combustion where applicable, and general ventilation, in addition to that required for any other appliance.

7.1 Air Supply By Natural Ventilation (Open-flue installation only)

The boiler room must have, or be provided with, permanent air vents directly to the outside air, at high level and at low level. For an exposed boiler house, air vents should be fitted preferably on all four sides, but at least on two sides. Air vents should have negligible resistance and must not be sited in any position where they are likely to be easily blocked or flooded or in any position adjacent to an extraction system which is carrying flammable vapour. Grilles or louvres must be so designed that high velocity air streams do not occur within the space housing the boiler.

The air supplied for boiler house ventilation shall be such that the maximum temperatures within the boiler house shall be as follows:

- 1) At floor level (or 100mm above floor level) = 25°C.
- 2) At mid-level (1.5m above floor level) = 32°C.
- 3) At ceiling level (or 100mm below ceiling level) = 40°C.

Where both low and high level openings are used, the grilles shall have a total minimum free area of :-

Low Level - (inlet) **550cm² per boiler.**
 High Level - (outlet) **275cm² per boiler.**

7.2 Air Supply (Room-sealed installation)

If the Ferndown is installed as a room-sealed boiler **within a room** there is no requirement for the room to have additional ventilation.

If the Ferndown is installed as a room-sealed boiler **within a cupboard or compartment**, the enclosure shall be provided with both high and low level air vents

sized in accordance with the following.

Figure 7.2 Minimum Air Vent Requirements per Boiler Installed in a Compartment

Vent position	Compartment ventilated to:	
	Room or internal space	Direct to outside air
	cm ² /boiler	cm ² / boiler
High level	700	350
Low level	700	350

7.3 Air Supply By Mechanical Ventilation (Open-flue installation only)

Air supplied to the boiler room by Mechanical means should be as follows :-

- 1) Mechanical inlet and mechanical extract can be utilised providing the design extraction rate does not exceed one third of the design inlet rate.
- 2) Mechanical extract ventilation with natural inlet ventilation **MUST NOT** be used.

NOTE: For Mechanical ventilation systems an automatic control should be provided to cut off the gas supply to the boiler, in the event of failure of air flow in either inlet or extract fans.

Figure 7.3 Mechanical Ventilation Flow Rates ... (Open flue installation only)

Forced / induced	Flow rate per 1000kW total rated heat input (Gross)	
	Inlet air (Combustion ventilation)	Extract air (ventilation)
	m ³ /s.	m ³ /s.
Volume	0.90	0.60

8.0 WATER CIRCULATION SYSTEM

8.1 General

Recommendations for central heating water circulation system are given in **BS 6644** and **CP 342**. The following notes are of particular importance:-

- 1) In a combined central heating and hot water system, the circulating pipework not forming part of the useful heating surface should be insulated to help prevent heat loss and possible freezing, particularly where pipes are run through roof spaces and ventilated cavities. Insulation exposed to the weather should be rendered waterproof
- 2) The Ferndown is supplied with two R1¼ male flow and return connections located on the thermal storage tank. See figure 11.1
- 3) Valves should be fitted adjacent to the Ferndown to

enable isolation from the system, however, the arrangement must comply with the requirements of **BS 6644**. See **Section 10.4 Water Connections**.

8.2 Pressure Relief Valve (Safety Valve)

The Ferndown is supplied with a temperature and pressure relief valve factory fitted and set at 3 bar and 95°C.

8.3 Open Vented Systems

The Ferndown appliance is not suitable for connection into open vented systems.

8.4 Altitude Gauge (Water Pressure Gauge)

The Ferndown is supplied with a factory fitted pressure gauge located on the thermal storage tank inside the plastic cover. If connecting to central heating systems an additional pressure gauge should be located in a visible position.

8.5 Thermometer

If connecting the Ferndown into a central heating system a thermometer complete with pocket should be fitted in the pipework to indicate water flow temperature. See Figure 1.1. for typical position.

8.6 Drain Valves

The Ferndown thermal storage tank is provided with a ½" drain valve intended for draining the boiler and tank only. When connecting to central heating systems additional drain valves should be located in accessible positions which permit the draining of the central heating system as recommended by **BS 6644**. See Figure 1.1. for suggested positions.

8.7 Circulating Pump

If connecting the Ferndown into a central heating system one or more circulating pumps will be required to circulate water around the heating system. The pump should be sited to facilitate servicing. When the Ferndown is used to replace appliances on an existing system it is important that the existing system be flushed through twice to remove any loose matter, which may have accumulated. If in any doubt regarding the cleanliness of the system, a coarse filter should be fitted in the return pipework from the central heating system.

Note that the Ferndown flow temperature is factory set at 80°C and cannot be adjusted. It is recommended that the heating system is sized and operated with 80°C flow and 70°C return. Provided that the system is operated within these parameters the effect of the Ferndown on the central heating system pressure losses will be negligible.

8.8 Controls

8.8.1.1 Temperature Controls

The temperature of the water outflow is factory set at 82°C and should not be adjusted.

8.8.1.2 Thermostatic Mixing Valves

For space heating applications, the Ferndown has a constant flow (un-adjustable) temperature of 80°C, therefore thermostatic radiator valves should be used to control the temperature.

8.8.2 Frost Protection

The Ferndown is an instantaneous water heater designed to run continuously resulting in the primary loop circuit always being at approximately 80°C. If connecting the Ferndown into a central heating system where elements of the system are subject to exposure to low temperature consideration should be given to fitting a frost thermostat set at approximately 4°C.

8.9 Unvented Systems

See Figure 1.1. for typical layout of an Unvented (Pressurised) Hot Water System. For system design refer to **BS 7074 Part 2**.

In order to correctly size a pressurisation unit for any heating system certain parameters are required. These are:-

- 1) Static height of highest component in system (metres).
- 2) System volume - if it is not known a general rule of thumb of 10 litres/kW of installed boiler power can be used.
- 3) Maximum flow temperature (°C).
- 4) Maximum system hot working pressure, generally given in bar gauge.

From the above information Hamworthy Heating can size the pressurisation unit and also the expansion vessel required.

Care must be taken in sizing expansion vessels to ensure maximum acceptance factors are not exceeded. Normally manufacturers of vessels impose a limit of 0.5. This value must not be exceeded at any time during the operation of the boiler, this includes the over pressure condition should a safety valve lift.

Note: The factory fitted T & P valve is set at 3 bar which should be taken into consideration when determining system operating parameters.

8.10 Boiler Control Scheme

Ferndown installations can be operated in fully modulating mode, controlled from a simple time-clock or BMS system via a remote stop/start loop. – see Figure 8.10.

The boiler module can be set to run in the hi/lo mode however this operating scheme is not recommended for water heating applications.

9.0 ELECTRICAL CONNECTIONS

WARNING: THIS APPLIANCE MUST BE EARTHED

Wiring external to the boiler must be installed in accordance with the IEE Regulations and any local regulations, which apply. Wiring must be completed in heat resistant cable. (Size 0.75mm² csa). Boilers are normally supplied suitable for 230 volts, 50 Hz. Boiler fuse rating is 1 A. External fuses should be 6 A. for all boilers.

9.1 Electrical Supply Connections

The method of connection to the mains electricity supply must facilitate complete electrical isolation of the appliance with a contact separation of at least 3mm in all poles. This mains isolator must be provided adjacent to the Ferndown in a readily accessible position. The supply should only serve the appliance.

The appliance must be isolated from the mains electricity supply in the event of electric arc welding being carried out on any connecting pipework.

NOTE! It must be possible to isolate Volt free contact electrical supplies where fitted. Further details regarding connection to the electricity supply are given in **BS EN 60335, Part 1 or BS 3456, Part 201**.

The power supply to the appliance should not be switched by a time clock. The Ferndown has a remote stop/start loop, which can be used to operate the boiler under a timed regime. This remote loop requires a volt free contact for operation. A 12V dc signal is supplied by the boiler for this circuit to function. Refer to Figures 8.12 and 9.1 for wiring connection details. See **BS 6644** for further information. Do not modify this circuit in any way.

9.2 Indication Signals and Volt Free Contacts

Volt free contacts are provided to enable external indicator lights or alarms to derive signals for normal run, overheat and lockout.

Note:- These external circuits **MUST** be isolated before any service or maintenance procedures are carried out.

9.3 Cable Installation

Access to the controls is achieved by removing the top and bottom plastic covers. The cover frame contains two 20mm dia sockets on the bottom left hand side, for electrical cable conduit anchorage prior to entering the cabinet. Internally the appliance is provided with two 20mm dia. flexible conduits connecting the cover frame to the control panel.

All site cables must be routed through the flexible conduits to terminate in the control panel.

Care must be taken to ensure correct connections

10.0 APPLIANCE ASSEMBLY AND INSTALLATION

10.1 General

The Ferndown is supplied as a factory assembled and tested appliance plus a flue kit dispatched separately from the main appliance.

10.2 Assembling & Positioning The Appliance.

10.2.1 Select the position of the water heater in the plant room ensuring that the minimum clearances nominated in Figure 2.1 are achievable. - refer to **section 4** For description of terms.—refer Figure 11.1.

Carefully remove the packaging from the water heater and unscrew the coach screws holding the timber rails to the base of the frame. Knock out the timber rails so that they are splayed and allow the appliance to gently tilt forward until the base frame rests on the floor. Tilt the frame forward and knock out the timber rails.

If the rear flue exit is being used, mark the position of the flue exit hole as indicated in figure 2.1 and core drill for the flue pipe (150mm dia.). For all other flue installations refer to **section 10.3**.

Position the water heater in the desired location ensuring it is level both horizontally and vertically. Once located the frame base is provided with 4 x 11mm holes for bolting the frame to the floor via M10 bolts (Non HHL supply).

Remove the plastic front covers by turning the ¼ turn latches located along the front of the appliance and lift the covers off. Remove both side panels by gently pulling the panels off of the retaining ball studs. Remove the cover support band via the four off M8 nuts and washers.

10.3 Connection of Boiler Module to the Flue System

Dependent on boiler installation a number of flue options are available refer to Figures 6.1. **In all instances, the flue must be obtained from Hamworthy or in the case of connection to an open flue system, the ducts up to the chimney must be obtained from Hamworthy.**

The maximum allowable length of the flue must be determined in accordance with **section 6.4**. It is also important, for service requirements, that the flue system is fully self-supporting and that prior to commissioning a check has been made to ensure that the pipe is clear and free from obstruction.

Figure 8.10 Site Wiring Diagram

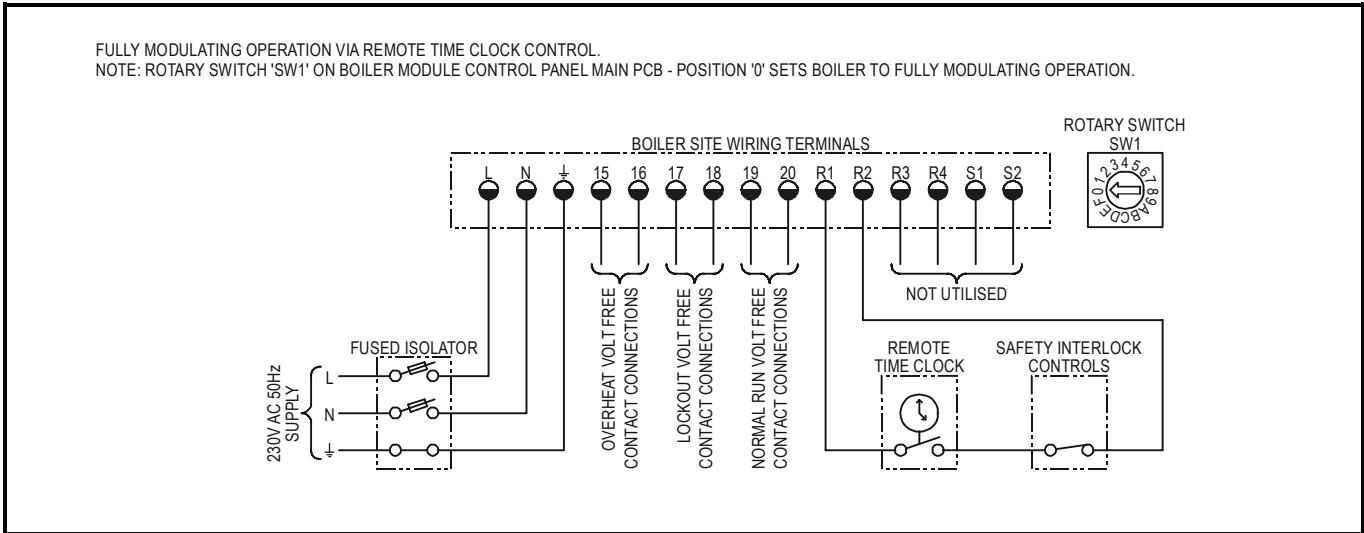

Figure 9.1.1 Wiring Schematic (Auxiliary Control Panel)

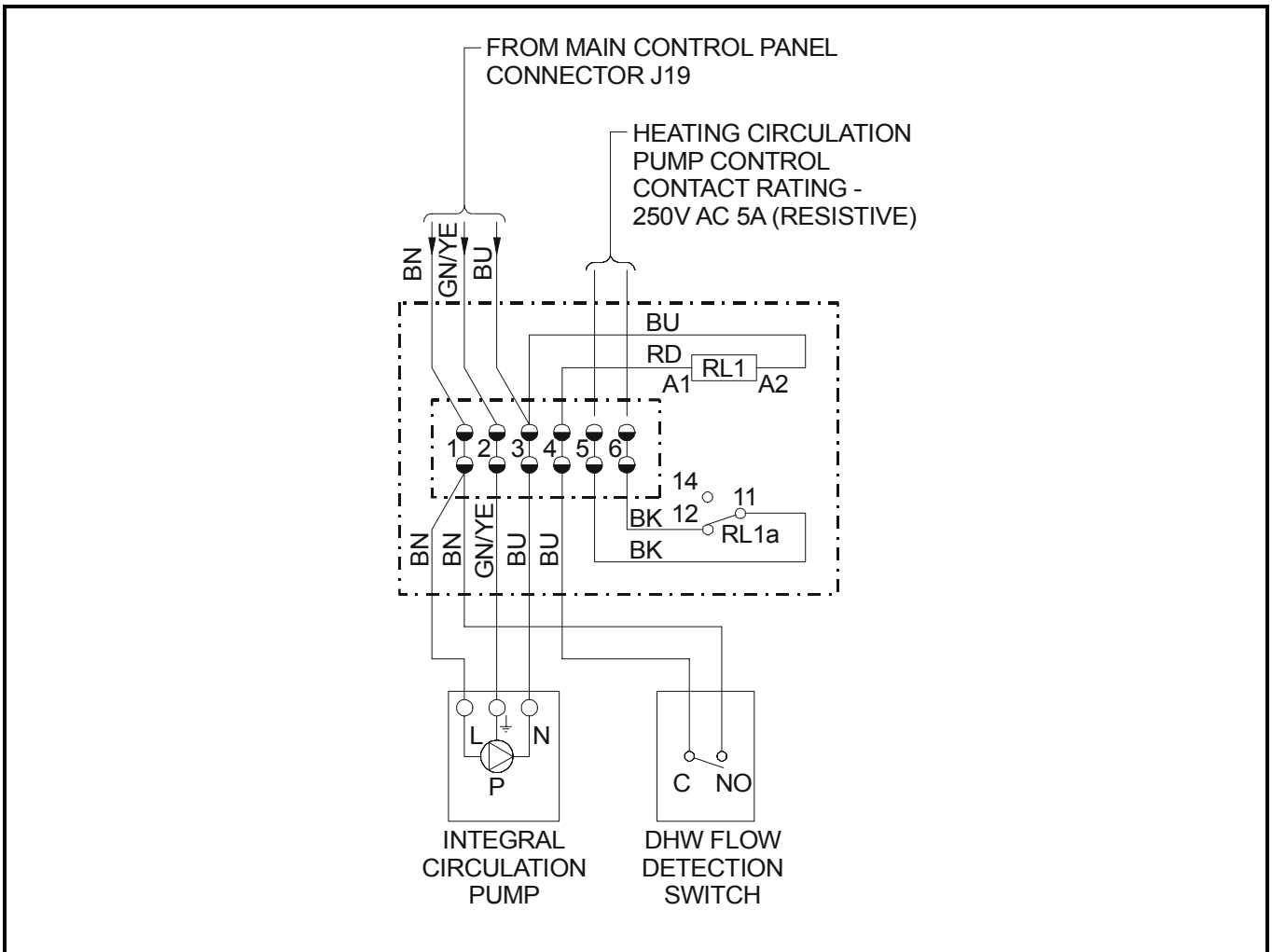
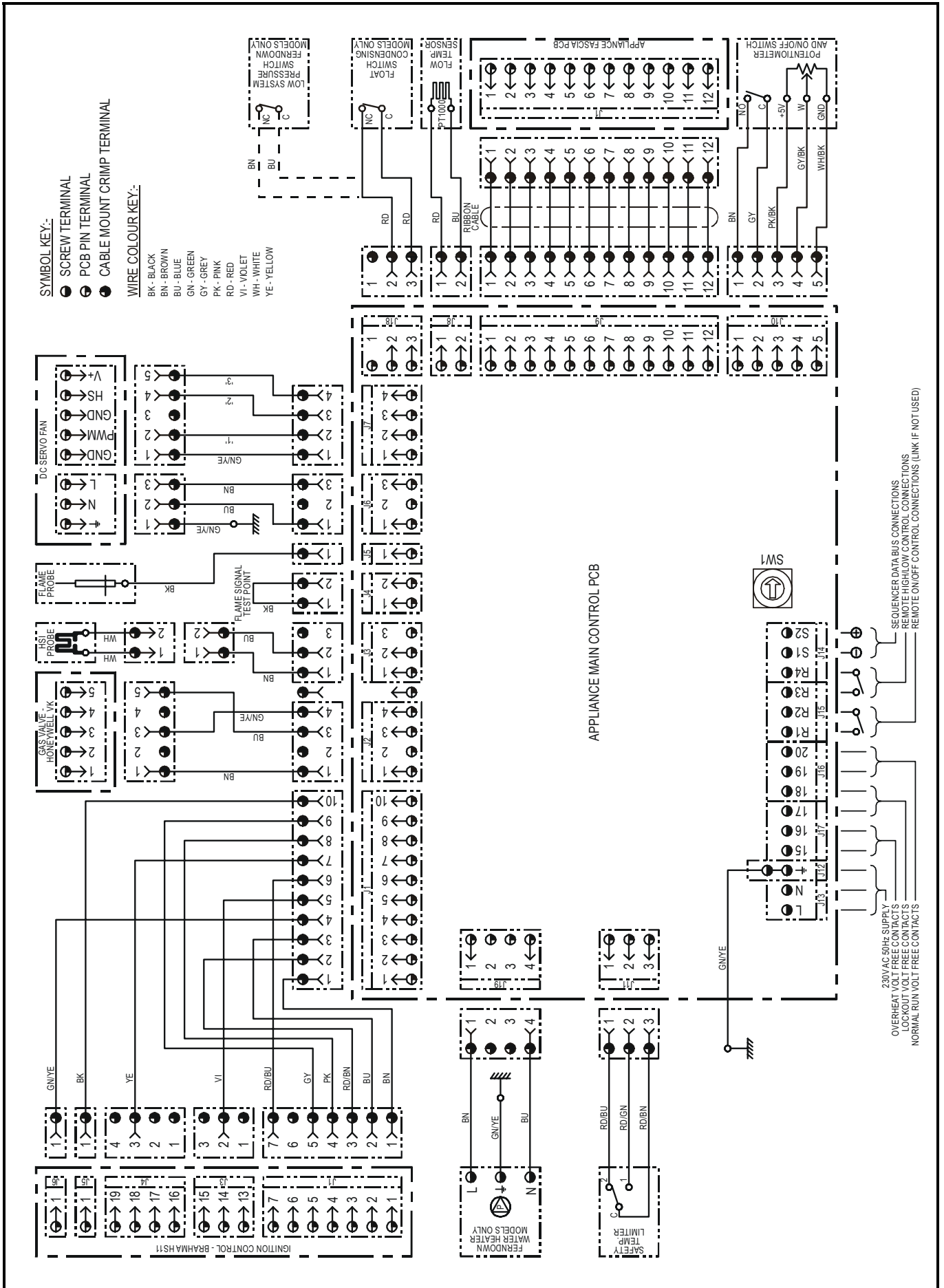

Figure 9.1.2 Wiring Schematic (Main Control Panel)



10.3.1 Connection of Through Wall Horizontal Balanced Flue Terminal – 80/125mm.

For applications where the rear of the appliance is stood away from the wall, flue extension packs are available, consult Hamworthy Heating Technical Department for help or assistance if in doubt.

Ensure that the appliance is positioned in its correct location and that the clearances nominated in figure 2.1. are achieved.

Remove the appliance connector by gently pulling out of the boiler casing socket. Remove the air inlet chamber by firstly slackening the nuts and withdrawing along the axis of the venturi. Loosen the two M6 fastenings attaching the flue support cradle.

The flue terminal should be cut to length as detailed in figure 10.3.1.1. Check all measurements before cutting and **take care not to damage the inner tube when cutting the outer tube.**

Note: Deburr both tube ends and ensure that the cuts are square. Failure to carry out this operation carefully may result in damage to the flue seals when assembling the flue system.

From the inside of the building fit the flue terminal through the flue support cradle and the cut out in the rear mesh panel, and on into the hole drilled through the wall. Push the terminal forward sufficiently until the inner wall sealing plate can be threaded over the end of the terminal and then pull the terminal back to sandwich the wall plate between the appliance mesh and the wall. Loosely fit the concentric adapter to the rear of the flue protruding into the boiler. Fit the appliance connector duct between the concentric adapter and the flue outlet in the aluminium boiler casing to ensure that cut lengths are correct and that the assembly aligns correctly. Without disconnecting the assembly go to the outside of the building and offer the outer wall sealing plate up over the terminal and position it such that there is a 2° slope from the terminal to the boiler connection to allow any condensate to run back to the boiler. Mark the four securing holes, drill and plug the holes and secure the wall plate.

Return to the inside of the building and push the terminal fully forward until the bead engages with the outer wall plate. Slide the inner wall sealing plate up to the face of the wall and position it such that there is a 2° slope from the terminal to the boiler connection, mark the four securing holes. Remove the appliance connector, and flue concentric adapter, drill and plug the wall plate holes. Secure the inner wall plate and rotate the terminal as required to ensure the correct orientation of the terminal discharge.

Re-secure the flue support cradle onto the cover panel work by tightening the two M6 fasteners and ensure that the orientation of the terminal is correct at the terminal outlet. Fit the concentric adapter. Engage the air inlet box onto the left hand connection of the concentric adapter as shown in Figure 10.3.1.1. and secure in place by tightening the M8 nuts finger tight. Fit the appliance connector duct between the flue outlet in the aluminium boiler casing and the flue duct. The vertical leg of this duct is telescopic to assist with installation. Whilst carrying out the above procedure

ensure that all seals are correctly located and provide gas tight joints.

Figure 10.3.1.1. Connection of Flue System (Concentric Ducts Horizontal)

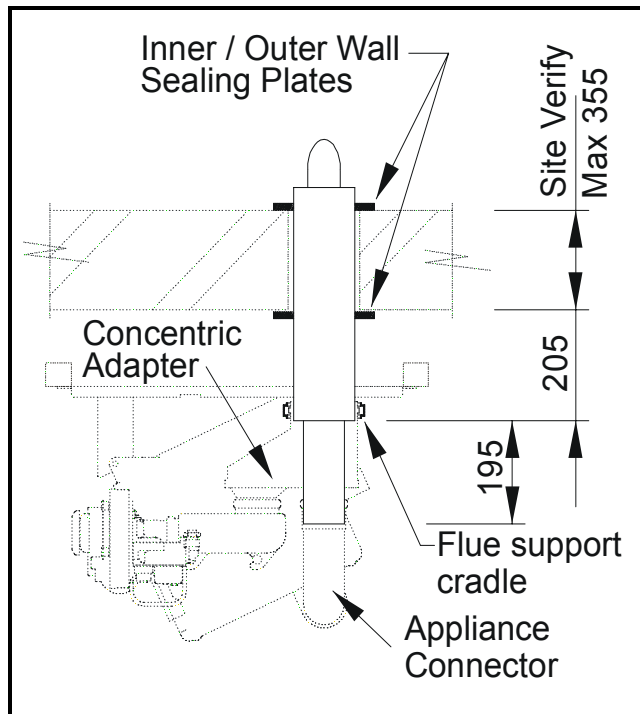
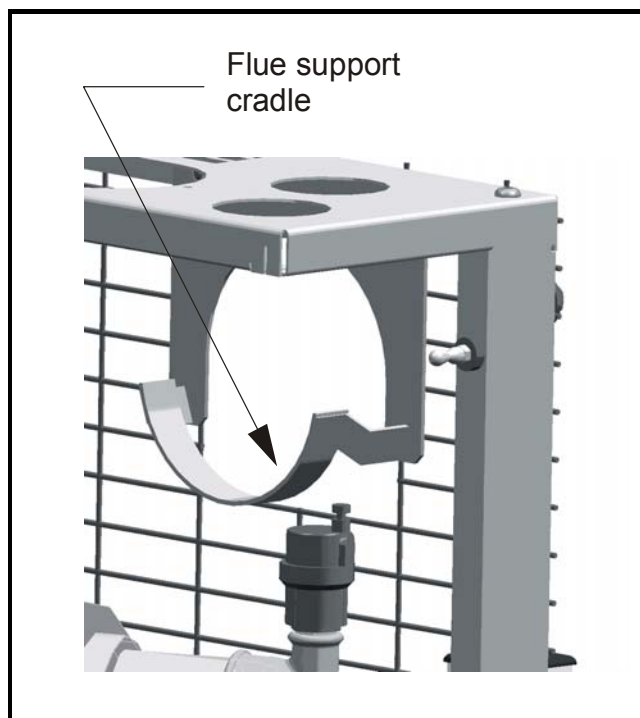

Figure 10.3.1.2. Flue Support Cradle



10.3.2 Connection of Extended Lengths of Horizontal/Vertical Balanced Flue – 100/150mm.

Having established the flue termination point, a hole 170-180mm dia. should be made through the wall or roof.

Note: the flue support cradle is not required for this installation and should be removed and replaced with the elbow mounting bracket refer Figure 10.3.1.2. Refer to Figures 6.1.1, 6.1.2, and 10.3.2, locate the two 90° elbows onto the mounting bracket lugs and fit the appliance connector duct between the flue outlet in the aluminium boiler casing and the 90° discharge support elbow. The vertical leg of this duct is telescopic to assist with installation. Insert the 90° inlet support elbow into the air inlet box. Insert the 80 to 100mm adaptors into the outlets of the two 90° elbows and engage the twin pipe to concentric adaptor into the left hand (air) 100mm tube and orientate such that the discharge socket is coaxial with flue discharge adaptor. Fit the flue make up piece through the socket into the flue discharge adaptor after which either a 90° concentric elbow or straight vertical section can be fitted. Fit the remaining flue components on route to the terminal discharge ensuring a minimum 2° slope and that the flue system is self-supporting using wall brackets where necessary. In terminating the flue system, ensure that the joint through the wall / roof is made good and weatherproofed. Whilst carrying out the above procedure ensure that all seals are correctly located and provide gas tight joints.

Figure 10.3.2 Connection of Flue System (Concentric Ducts Vertical)

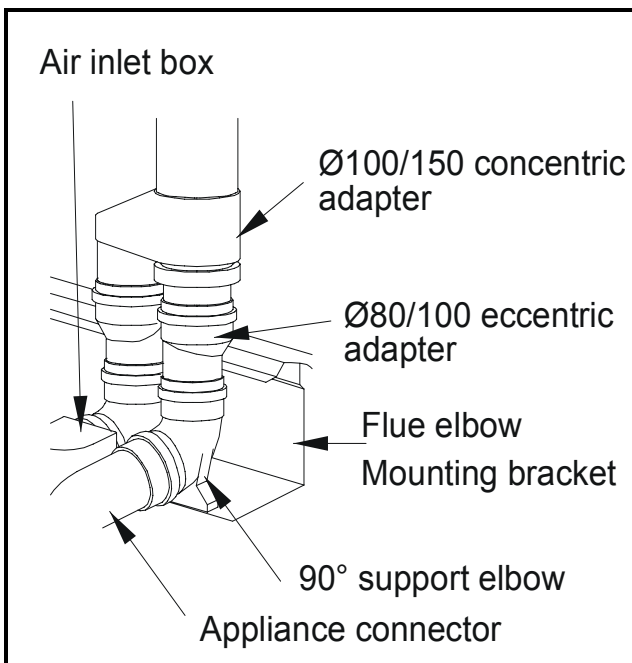

10.3.3 Connection of Twin Pipe Horizontal/Vertical Room Sealed –100mm

Note: the flue support cradle is not required for this installation and should be removed and replaced with the elbow mounting bracket refer Figure 10.3.1.2. Refer to Figures 6.1.1, 6.1.2, and 10.3.2, locate the two 90° elbows onto the mounting bracket lugs and fit the appliance connector duct between the flue outlet in the aluminium boiler casing and the 90° discharge support elbow. The vertical leg of this duct is telescopic to assist with installation. Insert the 90° inlet support elbow into the air inlet box. Insert the 80 to 100mm adaptors into the outlets of the two 90° elbows. Fit the remaining flue components on route to the terminal discharge ensuring a minimum 2° slope and that the flue system is self supporting using wall brackets where necessary. In terminating the flue system, ensure that the joint through the wall / roof is made good and weatherproofed. The top of the plastic boiler cover has a D shaped recess that marks the position of the vertical flue exit point. Using a suitable fine toothed hacksaw or jigsaw, carefully cut around the inside of the recess to provide the flue outlet. Having fitted the flue system to the boiler, carefully refit the burner assembly and secure to the heat exchanger using the 2 – M6 nuts previously removed taking care not to damage the probes or the burner flange gasket see Figure 10.2. Reconnect the pressure feedback tube to the gas valve.

Figure 10.3.3 Connection of Flue System (Separate Ducts)

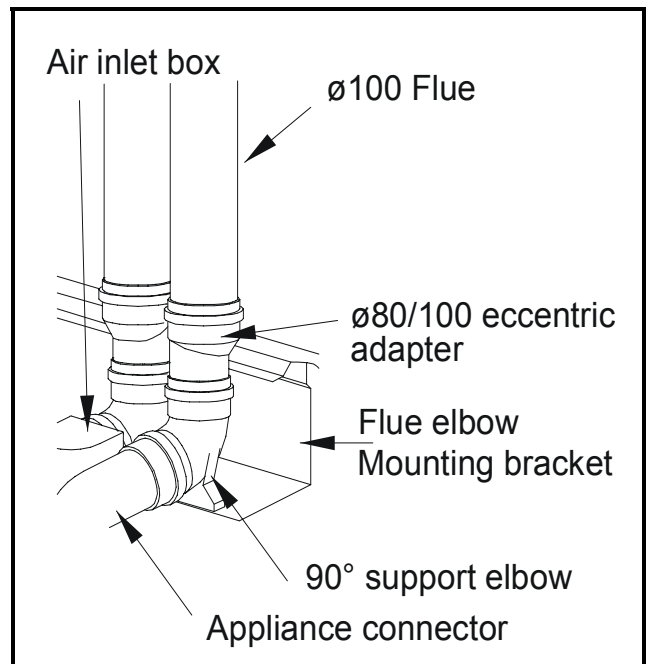

10.3.4 Connection of Single Pipe Horizontal/Vertical Open Flue – 100mm

Note: the flue support cradle is not required for this installation and should be removed and replaced with the elbow mounting bracket refer Figure 10.3.1.2.

Refer to Figures 6.1.4 and 10.3.4. Locate the 90°-discharge elbow onto the right hand mounting bracket lug and fit the appliance connector duct between the flue outlet in the aluminium boiler casing and the 90° elbow. The vertical leg of this duct is telescopic to assist with installation. Locate the air inlet terminal into the left hand 90° elbow. Fit the remaining flue components on route to the terminal discharge ensuring a minimum 2° slope and that the flue system is self supporting using wall brackets where necessary. In terminating the flue system, ensure that the joint through the wall / roof is made good and weatherproofed. The top of the plastic boiler cover has a D shaped recess that marks the position of the vertical flue exit point. Using a suitable fine toothed hacksaw or jigsaw, carefully cut around the inside of the recess to provide the flue outlet.

Having fitted the flue system to the boiler, carefully refit the burner assembly and secure to the heat exchanger using the 2 – M6 nuts previously removed taking care not to damage the probes or the burner flange gasket see Figure 10.2.

Reconnect the pressure feedback tube to the gas valve.

Figure 10.3.4 Connection of Single Pipe (Open Flue)

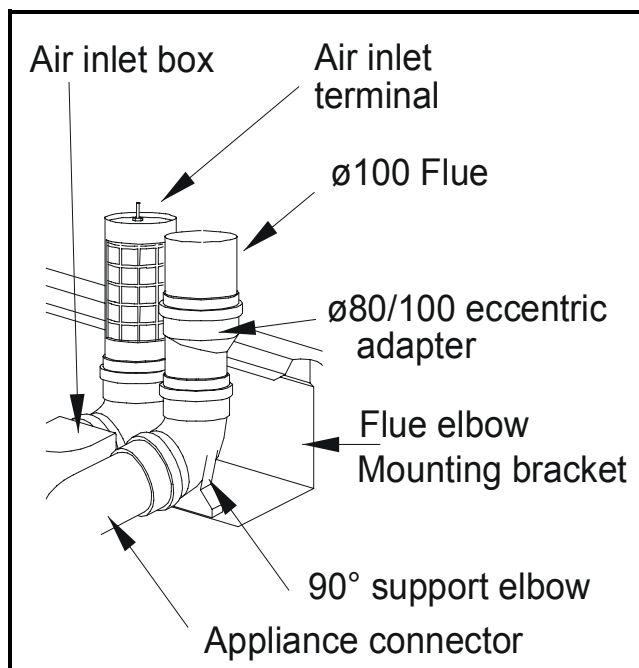

10.4 Water Connections

10.4.1 System Water Connections

See Figures 2.1 and 11.1. When connecting pipework care must be taken to avoid undue stress on the appliance connections. It is recommended that unions and isolating valves are fitted local to the appliance and outside of the casing, to permit future servicing requirements. Domestic water connections are made using 22mm copper tube and compression fittings.

10.5 Condense Trap Connection

A condensate trap (refer figure 11.1) is fitted to the appliance. Suitable 22mm waste pipe (Non HHL supply) should be routed through the aperture in the base of the cover frame adjacent to the gas connection. A small amount of sealant must be used on the waste pipe connection to the condensate trap.

10.6 T and P Valve Connection

Suitable 28mm discharge piping from the T & P valve (non HHL supply) should be routed to a visible tundish.

10.7 Fitting the Front Cover and Panels.

Fit the cover support band via the four off M8 nuts and washers. Refit the side panels ensuring that the ball studs are fully engaged and secure.

Position the plastic front covers over the cover support frame ensuring that the metal locating lugs are correctly aligned and secure in place by turning the ¼ turn latches.

11.0 COMMISSIONING AND TESTING

For general layout of appliance, refer to Figure 11.1

11.1 Electrical Installation

Wiring **MUST** be checked by a suitably competent person. Power supply required is 230 volts 50 Hz single phase. An isolator correctly fused at 6A should be sited close to the boiler.

Access to the main control panel is achieved by turning the ¼ turn catch located on the bottom flange of the top cover and lifting the cover up and away from the cover frame. To gain access to the auxiliary control panel the bottom cover and cover support band must also be removed. Electrical connections to the boiler should pass through the 2 x 20mm conduit connections located at the bottom left hand side of the cover frame. The appliance controls are supplied with a remote stop/start circuit for time clock operation. **Any other interlocks, i.e. Pressurisation unit, BEM System should be wired in series with the remote stop/start loop and not interrupt the permanent live feed.**

The site wiring connections are marked with Live, Neutral and Earth connections. See Figure 8.10, 9.1.1 and 9.1.2 for details.

IMPORTANT :- READ THE WARNING NOTE REGARDING EXTERNAL VOLTAGES.

11.2 Gas Installation

For design see **Section 5: GAS SUPPLY.**

The whole of the gas installation including the meter must be inspected and tested for soundness and purged in accordance with the recommendations of **IGE/UP/1** or **IGE/UP/1A** as appropriate.

11.3 Central Heating Water Circulation System

The Ferndown is fitted with a WRAS approved filling loop comprising double check valve and removable filling hose which is suitable for filling the central heating system. In order to comply with local Water Authority Regulations, this loop must be disconnected when filling is complete.

The system should be thoroughly flushed out with cold water without the central heating pump in position. Ensure all the valves are open.

With the pump fitted the system should be filled and air locks cleared. Vent the radiators and check for leaks.

Water treatment should not be fed through the pressurisation unit unless permitted by the manufacturer. Check the expansion vessel cushion pressure as detailed by the manufacturer's Installer's Guide.

11.4 Commissioning The Appliance

Only competent persons registered for working on non domestic gas appliances should attempt the following: Before attempting to commission any appliance, ensure that personnel involved are aware of what action is about to be taken and begin by making the following checks:-

- 1) Flueway passages to chimney are clear.
- 2) Adequate ventilation as per **Section 7: AIR SUPPLY** exists in the boiler house or compartment/room.
- 3) The system is fully charged with water, ready to receive heat. All necessary valves are open and if connected to space heating the main circulator pump is operational and circulating water.
- 4) The gas supply pipework is clear of any loose matter, tested for soundness and purged to **IGE/UP/1** or **IGE/UP/1A** as appropriate.
- 5) The condensate discharge is connected to a drain.
- 6) The T and P valve discharge is connected via suitable pipework to a visible tundish

11.5.1 Appliance Checks Prior to Lighting

NOTE! Refer to Figure 2.2. for Natural Gas maximum inlet pressure for normal operation.

Information relating to propane firing can be found in Appendix 'A'.

- 1) Ensure the gas supply is connected but turned to the "OFF" position. Any unions or fittings are correctly tightened and test points are closed.
- 2) Ensure electricity is connected but switched "OFF". The plug/sockets on the fan & gas valve connections are correctly located and that the temperature limiter bulb is fully inserted into the pocket, (control thermostat sensor in elbow). Test the operation of the temperature limiter by firmly pressing the button located on the controls fascia. Remove the clip and bulb from the thermostat pocket and carefully applying a heat source to the bulb. The reset button should operate. If satisfactory, refit the bulb in the pocket and secure with the clip.
- 3) Check setting of the temperature limiter which must not be set above 95°C maximum. Adjust if required, by turning the setting screw in the direction ±.
- 4) Set the thermostat mixing valves to the desired outlet temperature. Refer to Figure 11.3.1 below. The figures are approximate values.

Figure 11.3.1 Thermostatic mixing valve settings

Knob setting	Min	1	2	3	4	5	6	7	Max
Outlet temp	27	32	38	44	49	53	58	63	67

Figure 11.1 Appliance Layout

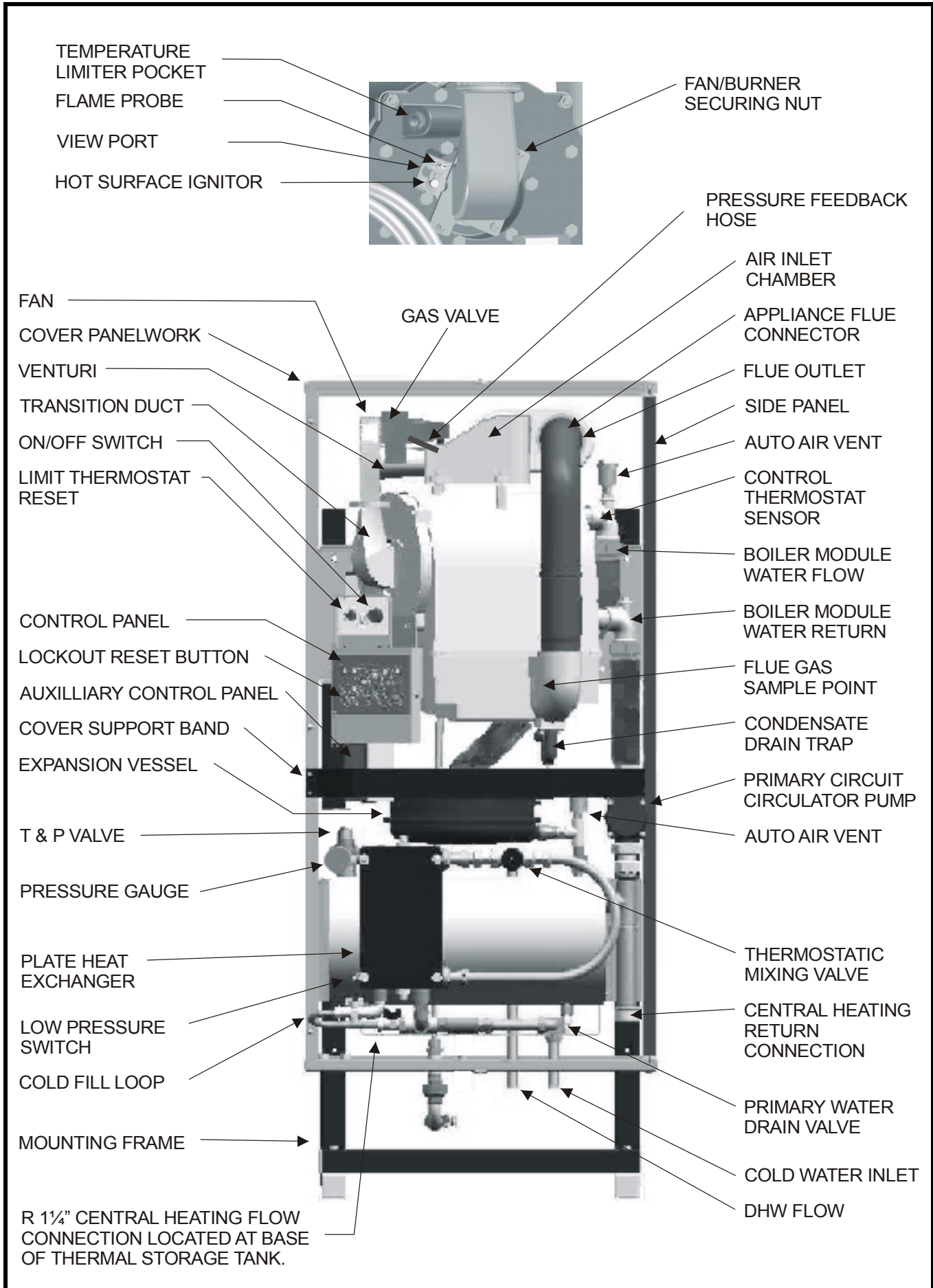

Figure 11.2 Gas Valve ~ Venturi Arrangement

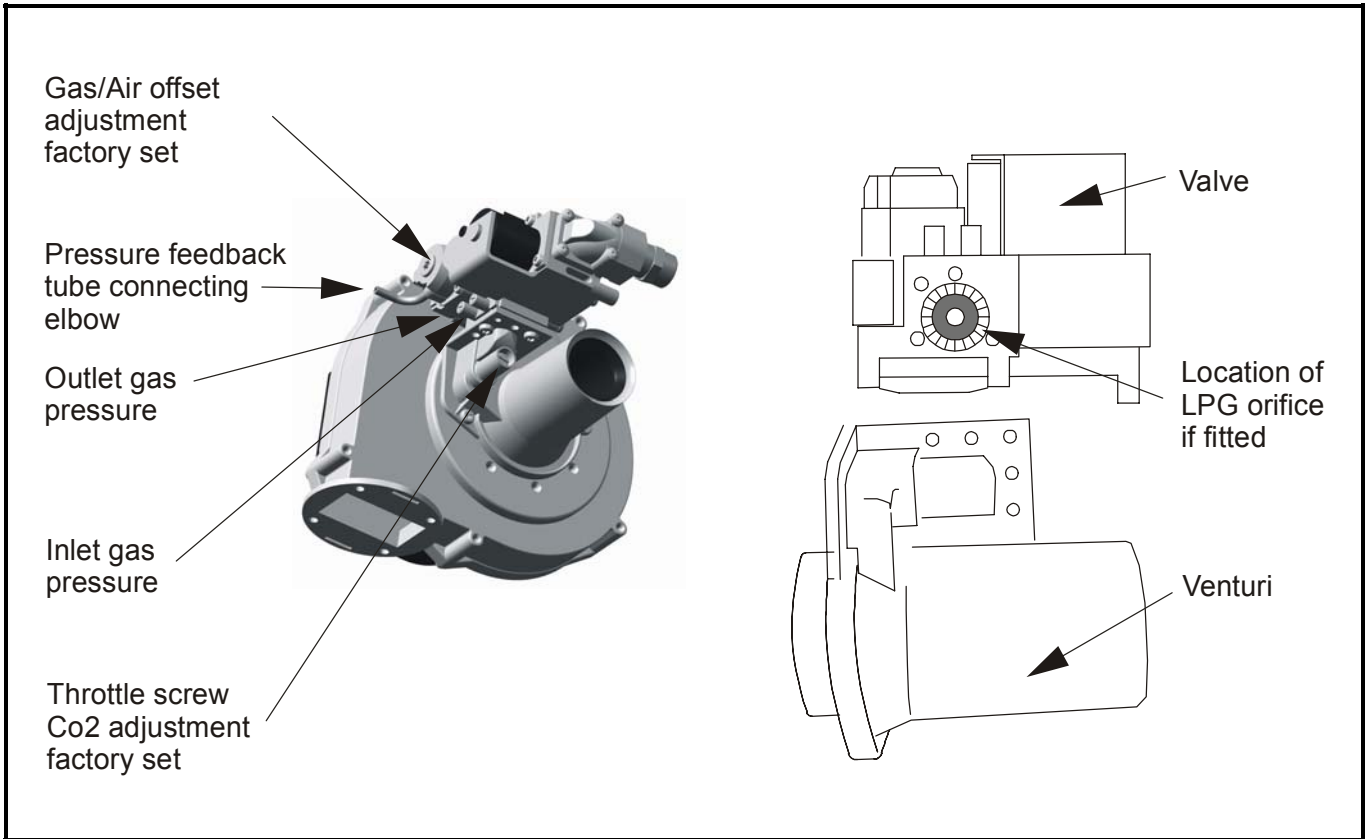
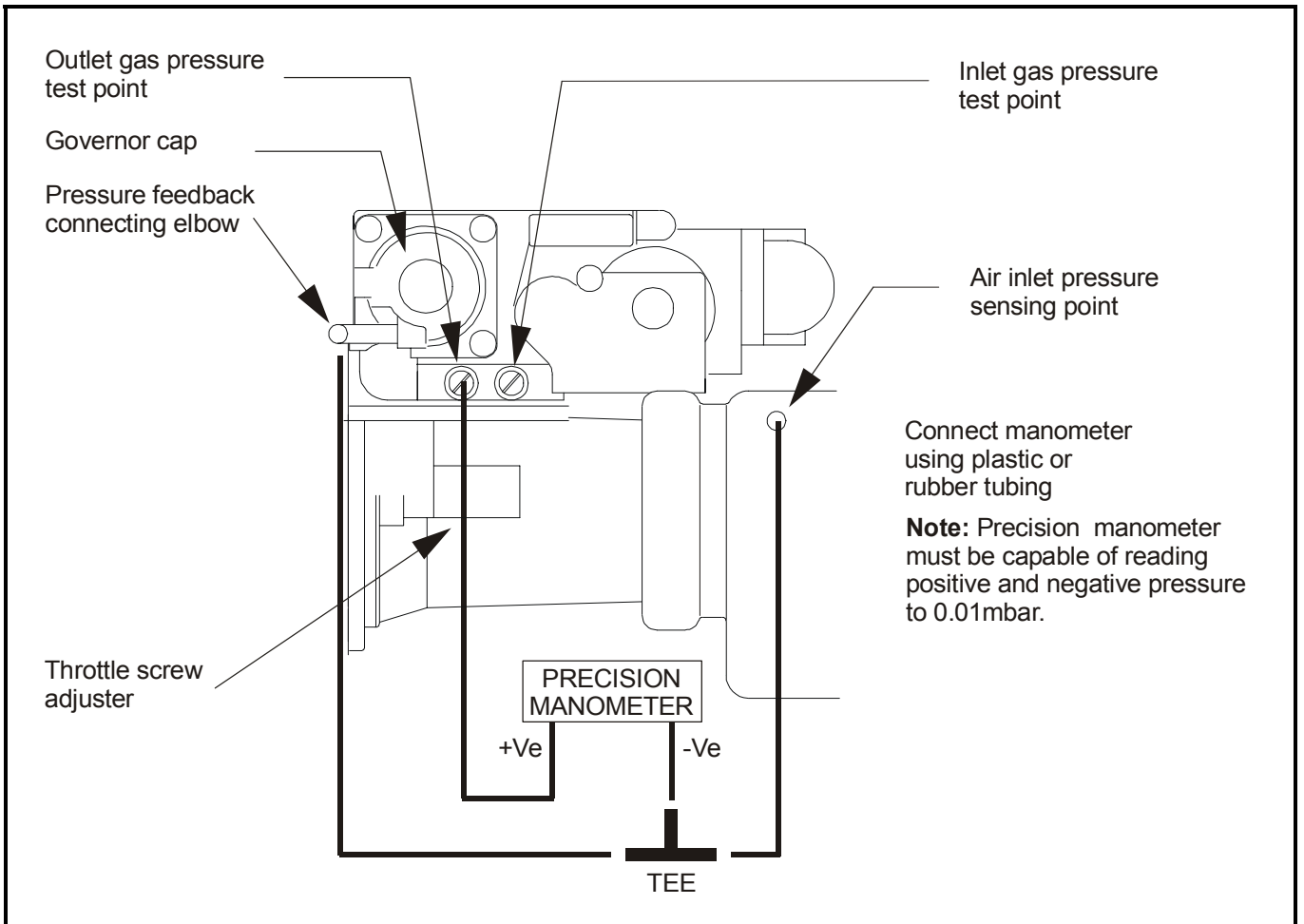

Figure 11.5 Instrumentation Set up for Initial Lighting and Offset Adjustment.



4) Remove the fascia panel and lay face down on the plate heat exchanger ensuring no strain on the ribbon cable. The terminal connections are located at the bottom of the main PCB. Figure 9.1.2 shows the correct location of incoming wires. Check for correct setting of rotary switch 'SW1' on the control panel main PCB – refer to Figure 8.10 for details. Remove the wire link on connector 'J4' (black wire) on the PCB and connect a multi-meter set to read DC μ A. across the terminals. Continue to operation 11.5.2. Procedure for initial lighting.

11.5.2 Procedure For Initial Lighting

Ensure gas service valve is in the "OFF" position and the electricity supply to the boiler is isolated. Rotate SW1 until the arrow points towards 'E' – refer to fig 8.10, 9.1.2 Link terminals R1 to R2 and R3 to R4 – refer to fig 9.1.2 (Note this linking scheme will operate the boiler at full rate, to achieve running at minimum rate remove link between R3 and R4). Energise electrical supply, press lockout button on fascia to re-set the controls, (wait at least 15 seconds before pressing again if the lockout neon is not extinguished). Press the on/off knob to switch on the boiler. The combustion fan will start and run for a purge period (approximately 20 seconds). During this time the 'fan on' neon should illuminate. After a delay, the HSI system will operate causing the igniter to glow (visible through the viewing port) for a period (approximately 10 seconds). As the gas service valve is closed, the controls should go to lockout after a further 5 seconds (red neon on fascia illuminated).

If the above occurs correctly, OPEN the gas service valve and ensure that sufficient cooling water is being passed through the appliance to enable firing, (run central heating circulator or open sufficient hot water taps) press re-set button on fascia.

After the purge period the ignition should be initiated and the main gas valve will energise lighting the main burner. **Note!** the multi-meter should be reading at least 2μ A. The boiler will operate at its start rate for 15 seconds before commencing modulation.

11.5.3 After the boiler module has operated for approximately 3 minutes, press the on/off knob to switch off the boiler, and connect a manometer to the pressure test point **on the gas valve inlet**. Re-light the module checking the inlet pressure, see Figure 2.2.

For Natural Gas the gas pressure governor control system is configured for a nominal gas inlet pressure of 20 mbar measured at the inlet to the gas valve, with a maximum inlet pressure of 25 mbar.

The air/gas ratio is factory set and sealed however should site conditions dictate adjustment is required the following procedure should be adopted by a person competent to carry out the work. Upon completion of adjustment the governor and throttle screw should be re-sealed using a small dab of paint or varnish etc. Note the offset can only be measured using a high precision manometer capable of reading ± 0.01 mbar, do not attempt to adjust the offset unless such equipment is used. Refer to figure 11.5, switch off the boiler

module and gently pull the pressure feedback tube off of the air inlet sensing point and connect the tube onto a suitable tee adapter. Connect similar tube between the tee flow and the air inlet pressure sensing point. Connect branch of tee to the -Ve side of the manometer. Open the outlet gas test pressure point and connect to the +Ve side of the manometer. Connect combustion analyzer to the flue gas sample point (see fig 11.1) and link terminals as per 11.5.2 to achieve high fire condition. Remove the governor cap to expose TORX adjuster screw. Switch on boiler and check that the CO₂ level is $9\% \pm 0.1\%$, if the combustion level is outside of this value adjust the throttle screw to trim within acceptable limits. Once the correct CO₂ level has been achieved set the offset value between the limits of 0 and -0.05 mbar by rotating the TORX screw in the governor.

Adjustment of the offset may cause drift in the CO₂ level therefore recheck that CO₂ is within acceptable limits, trim as required whilst ensuring offset tolerance is maintained. Remove link R3 and R4 to switch the boiler module onto minimum rate and check CO₂ level is $9.0\% \pm 0.1\%$. If the target combustion level is not achieved refit links R3 and R4 to set boiler module to hi fire rate and re-check offset and combustion values.

Switch "OFF" the boiler module, disconnect the manometer, close the pressure test point and refit the pressure feedback tube. Record all readings for future reference on the relevant commissioning sheet.

Isolate the electrical supply and rotate SW1 until the arrow points towards the required mode of operation for the boiler module (refer fig 8.10). Make/Break links R1 to R4 as dictated by site requirements. Re-energise electrical supply and switch on the appliance and allow system to warm up.

11.5.4. A combustion check must be taken when first commissioning the appliance. To measure the specified combustion results, a plugged sample hole is provided in the sump casting panel adjacent to the flue outlet.

NOTE! Care should be exercised if the boiler is firing as the flue can achieve temperatures which can cause injury if touched.

Combustion figures for Natural Gas should be as follows :-

CO₂ = $9.0\% \pm 0.1\%$ (Dry flue gas)

O₂ = 4.7—5.1%

CO = 0-65ppm: However figure should not exceed 200ppm under normal operating conditions.

Note an approximation of boiler heat input implied from the displayed fan speed can be determined using figure 11.5.4. For exact determination a gas meter should be used.

For LPG Propane firing - See Appendix 'A'.

Figure 11.5.4 Fan Speed VS Boiler Module Input

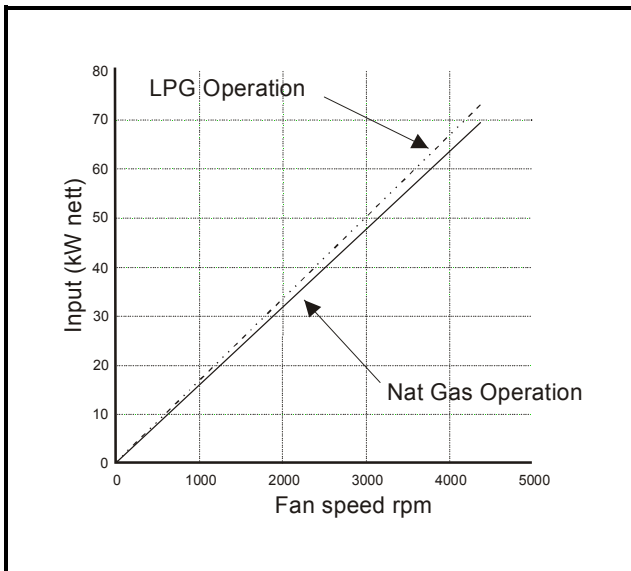

11.5.5 To check for correct operation of the controller, break the multi-meter μA circuit. The boiler module should lockout after approximately one second. Check that the flame has been extinguished. With the fascia panel removed, dis-connect the multi-meter and replace wire link J4, and front cover. Wait at least 15 seconds before pressing re-set button on fascia to re-set controller. After a waiting period the boiler will light and run normally.

11.6 External Controls

The external controls used in typical unvented central heating systems, are shown in Figure 1.1. If different systems or controls are to be used and there are any doubts as to the suitability, contact Hamworthy Heating Technical Department for advice.

11.7 User Instructions

When the above is complete, the boiler owner or their representative should be made aware of the lighting and operating instructions. A practical demonstration should be given describing each functional step. This Installer's Guide and user's instructions should then be handed over and be kept in a safe place for easy reference.

12.0 FAULT FINDING

12.1 Fault Finding

12.1.1 Safety Features Summary

The appliance is equipped with a T and P valve, low pressure switch, and temperature limiter. A pressure switch is fitted to the primary circuit to ensure that adequate water pressure is present against which the appliance can fire. Should the T & P valve lift discharging sufficient primary water to relieve water pressure rendering firing the appliance unsafe a lockout requiring manual reset will be initiated (indicate by 3

flashes of the fan light). A high temperature fault will result in the temperature limiter tripping thus creating an immediate shutdown regardless of firing mode. An overheat neon on the controls fascia will indicate this condition has occurred.

If, after pushing the overheat reset button, the neon on the fascia does not extinguish and the boiler does not fire up, it could be that the boiler is still too hot, i.e. the limit thermostat has not re-set, allow the boiler to cool down. An investigation should be carried out to ascertain the reason for the overheating. An obvious reason would be too low a water flow rate through the boiler.

The flame is under constant supervision by the burner sequence controller. This is accomplished by measuring the flame's ability to rectify an AC current. If the flame diminishes for whatever reason and the rectified current drops below the controllers minimum detection current ($1.2 \mu\text{A DC}$), the controller will induce a lockout within 1 second, which will require a manual re-set (situated on the controls fascia) to re-start the control sequence - see Failure to establish and detect a flame during the light up sequence, results in burner shutdown and lockout within 5 seconds. If the boiler continues to lockout, then an investigation must be made to ascertain the cause. See Figures 12.1 to 12.4 for possible corrective scenarios. False flame signals at the start and during purge will cause the boiler to lockout.

Restoration of the power supply after an interruption, results in a full light up sequence to safely restart the burner. Power failure after a lockout, will not interfere with this condition when the supply has been restored.

12.1.2 Fault Finding Procedures

General fault finding is shown in Figures 12.1 to 12.4. If the boiler still cannot be operated satisfactorily after following the chart, consult the local office of Hamworthy Heating for assistance.

12.1.3 Possible Causes Of Boiler Lockout

- 1) Ignition failure due to no power at the Hot Surface Igniter.
- 2) Ignition failure due to faulty gas valve.
- 3) Ignition failure due to broken igniter or flame probe lead.
- 4) No ignition due to faulty controller.
- 5) Ignition failure due to low primary water pressure.
- 6) Ignition failure due to gas supply problem.

Figure 12.1. Fault Finding Procedures.

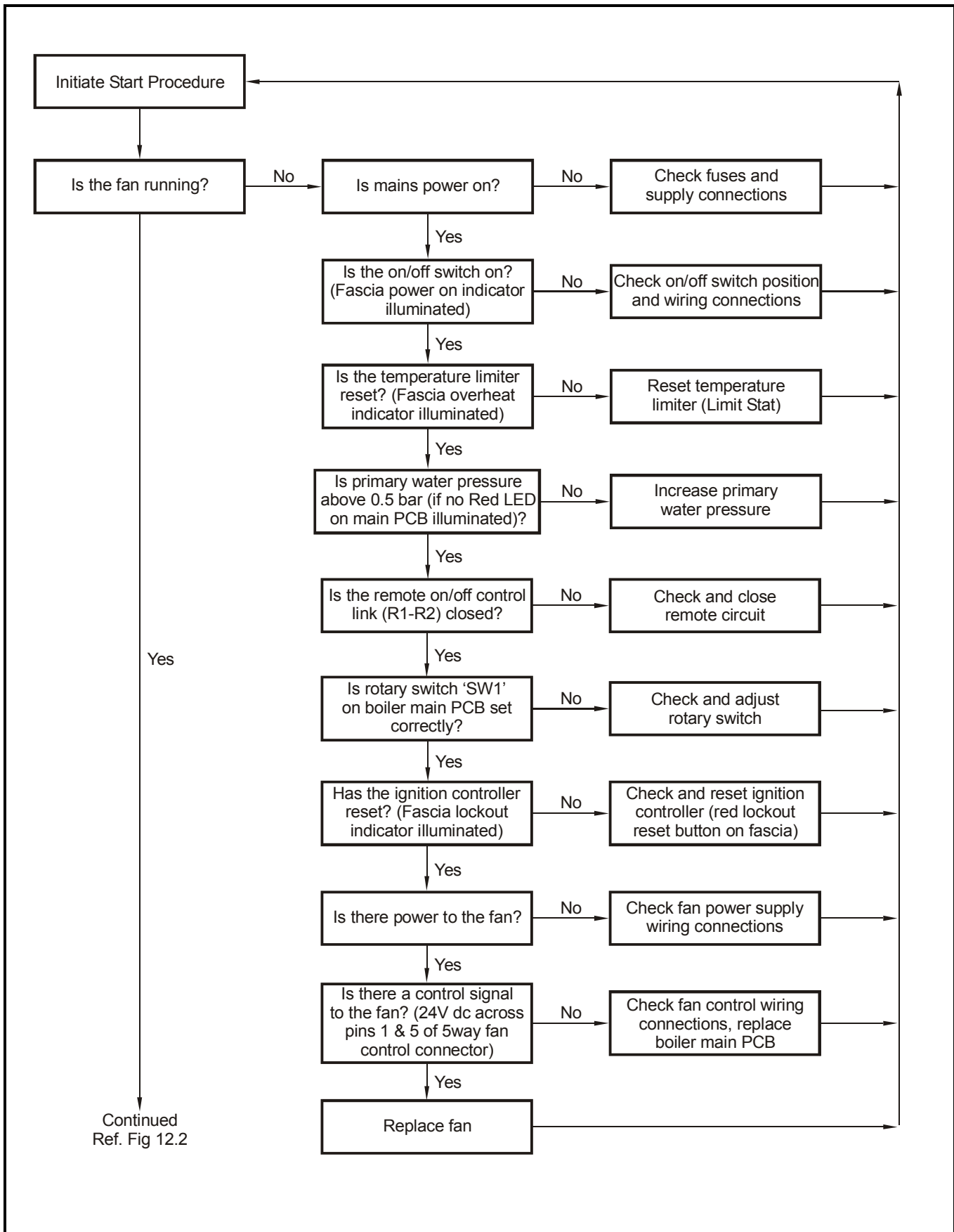

Figure 12.2. Fault Finding Procedures.

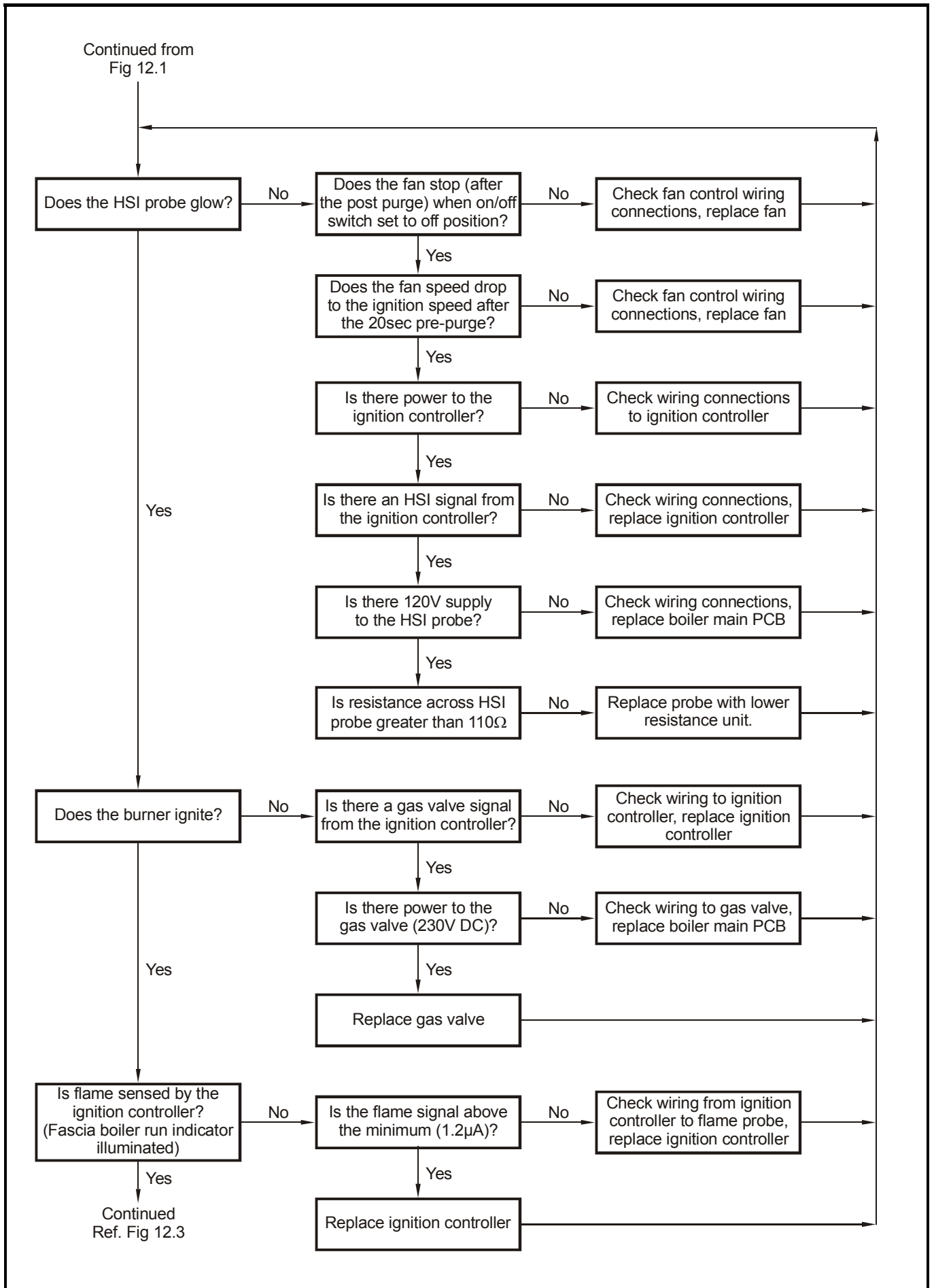

Figure 12.3. Fault Finding Procedures.

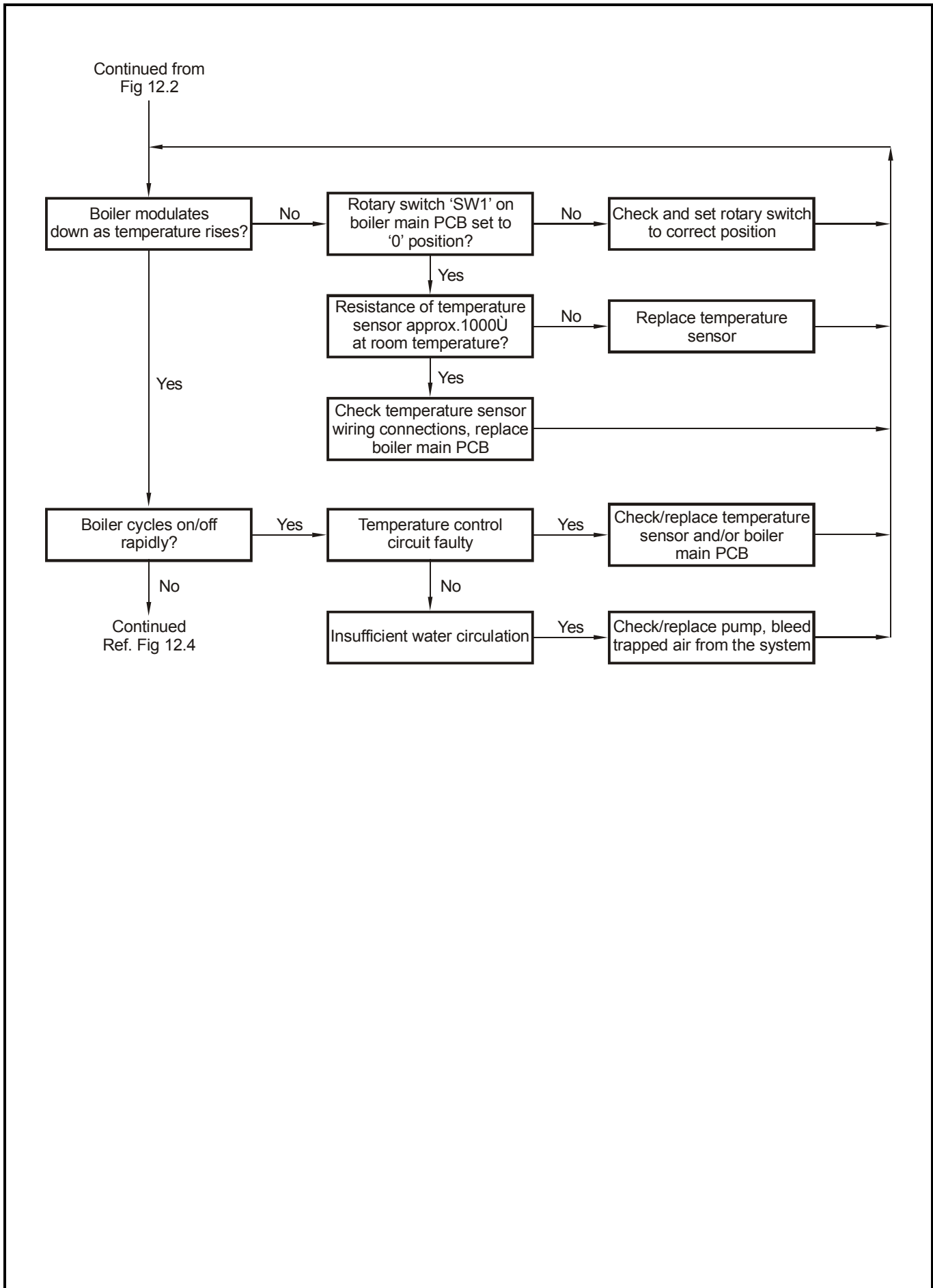
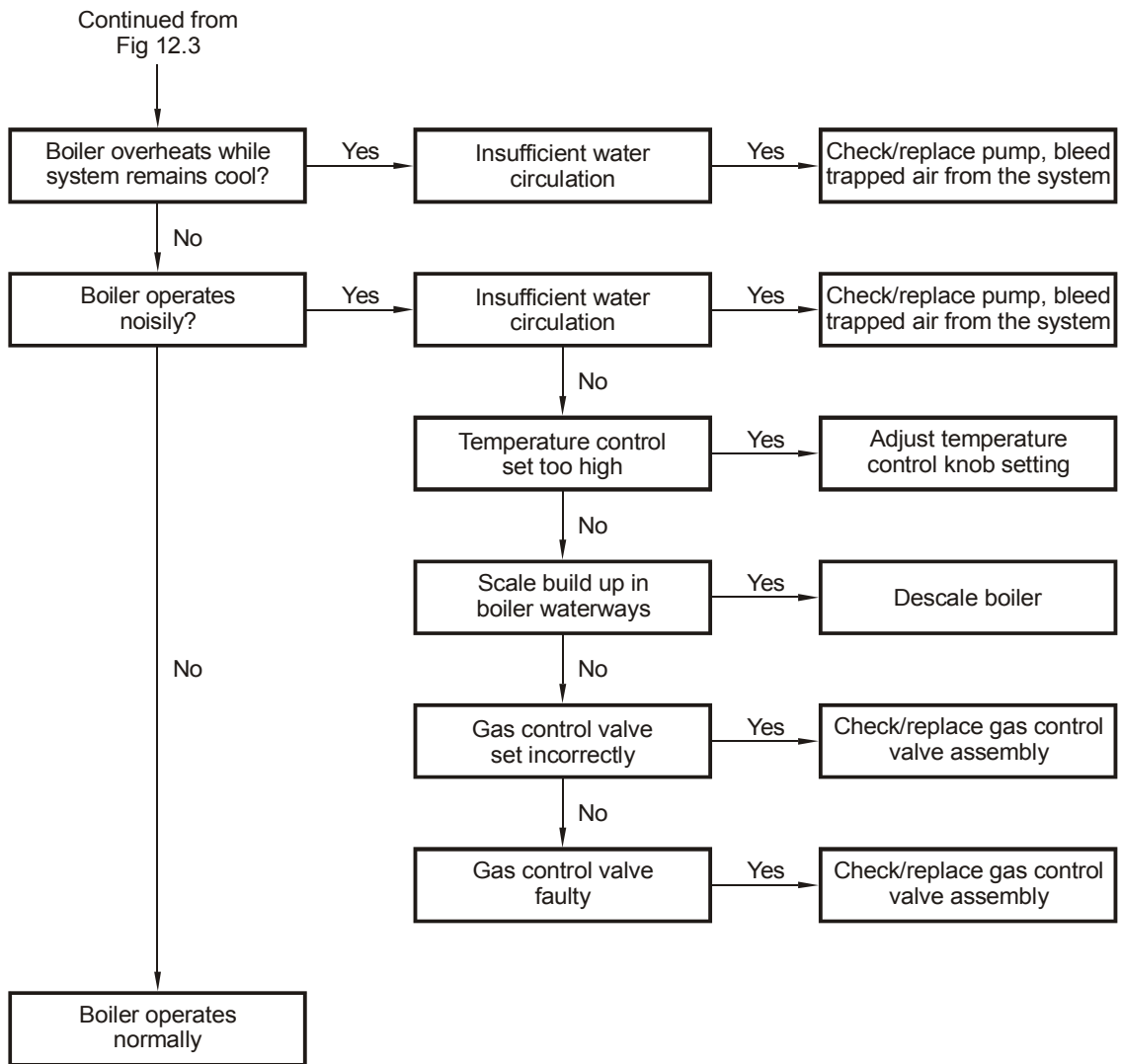

Figure 12.4. Fault Finding Procedures.



Boiler Fault Indication	
Certain boiler fault conditions are indicated by a sequence of flashes of the fascia fan running indicator	
Number of Flashes	Fault Condition
1 Flash	Ignition Lockout
2 Flashes	Fan Fault (Running at wrong speed or running when should be stopped)
3 Flashes	Primary water pressure low
4 Flashes	Overheat (high limit thermostat tripped)
5 Flashes	Premature flame detection (Flame sensing circuit fault)

13.0 SERVICING

A competent person registered for working on non domestic gas appliances should check and ensure that the flue, its support and terminal, the ventilation to the boiler house, safety valve, drain, water filter if fitted, pressure gauge, etc.; are in a serviceable and working condition and still comply with the relevant standards and codes of practice - see **Section 3**.

13.1 Regular annual servicing is recommended, preferably by a Hamworthy appointed person, to ensure trouble free operation. Although cleaning of flueways may not be necessary on a yearly basis, it is important that all controls and safety features are checked for correct operation.

NOTE! Measuring flue gas CO₂ and gas temperatures will give an indication of the state of the boiler flueways and waterways. Results should be compared with previously measured values to establish possible loss of efficiency.

13.2 Annual Service

Before servicing the appliance the following procedure must be carried out :-

WARNING: Isolate all electrical supplies and turn off the gas service valve.

1) Remove the plastic top outer cover by turning the 1/4 turn latch located at the bottom of the cover and lifting the cover up and away from the frame. Repeat the procedure, but push the cover down to remove the

bottom cover. Remove the two side panels by gently pulling away from the ball catches. Remove the cover support band via the M8 nuts and washers.

2) Disconnect the flame probe lead at the probe, and the igniter lead at the plug and socket. Unplug the connectors from the fan (two) and the gas valve. Disconnect the 15mm gas connection to the gas valve inlet.

3) Remove the 2 – M10 nuts and washers securing the controls panel to the heat exchanger, remove the controls panel and lay it face down on the top of the plate heat exchanger.

4) Disconnect the pressure feedback tube from the gas valve. Remove the 4xM5 screws/nuts securing the fan/venturi/gas valve assembly to the transition duct. **Note** the use of a spacer on the screw/nut nearest to the heat exchanger casting. Withdraw the assembly from the air inlet duct. Remove the 2xM5 screws securing the venturi/gas valve assembly to the fan. Clean the fan impellor and venturi tube with a soft brush if necessary.

5) Remove the 2 – M6 nuts securing the burner assembly to the front of the heat exchanger – see Figure 11.1 and carefully remove the burner assembly, taking care not to damage the probes or burner.

6) Remove the single socket cap head screws securing the igniter and flame probe to the burner flange. Carefully withdraw the igniter and probe. Remove the loose flange and Mica sight glass noting the position for re-assembly. Check condition of the igniter assembly and probe for damage, clean or replace as required.

Figure 13.2 Position of Probes on Burner Assembly

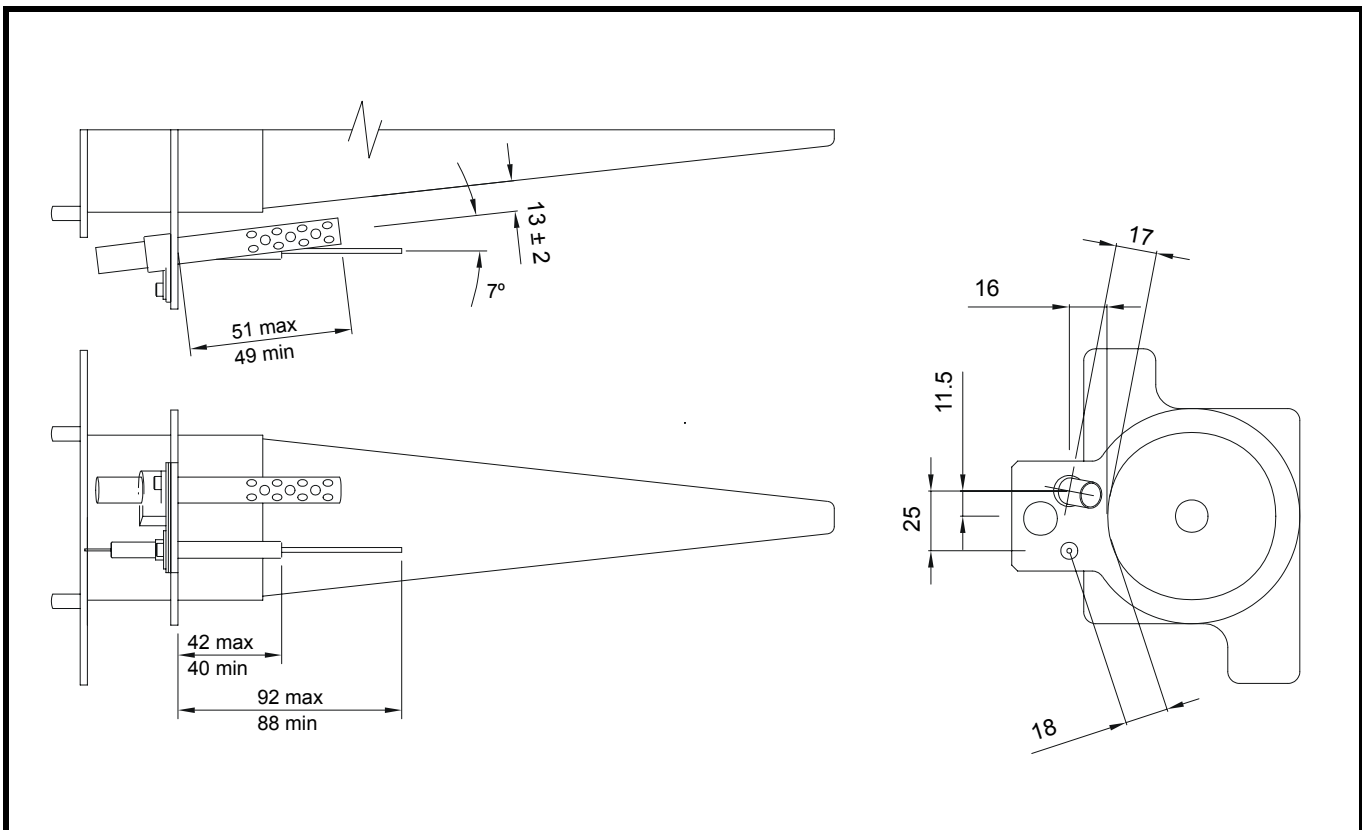

7) Remove the 2 x M6 nuts securing the transition duct to burner and separate the components.

8) Check the burner and clean using a soft brush if required (if possible use compressed air to blow out the dust inside the burner tube). Alternatively the burner tube can be washed using a soapy water solution. Tap the burner flange firmly downwards on a block of wood to dislodge any residual debris from inside the burner tube. A damaged burner should be replaced. (Fit the igniter and probe to the burner flange to check the respective positions - See Figure 13.2)

Re-assemble in reverse order checking the condition of gaskets and replace if necessary.

Refer to **Section 11, Commissioning and Testing**, and test all gas joints broken or disturbed for soundness before firing.

Carry out a combustion check by testing the flue gas CO₂ and CO levels as detailed in **Section 11.4** onwards

13.3 Two Year Service

Repeat the annual service as previously described but do not refit any components prior to cleaning the heat exchanger.

Two methods of cleaning the heat exchanger are recommended these being to either clean the heat exchanger in situ with the use of a high pressure water hose (40-80 psi) or removal of the heat exchanger from the module housing and wire brushing.

13.3.1 Cleaning with a high pressure hose.

Disengage the appliance flue connector from the sump casting. Remove the 2xM6 screws securing the condensate trap to the sump and disconnect the section of connecting pipe.

Support the sump from underneath and remove the 4xM6 securing nuts. Lower the sump casting to expose the heat exchanger and baffles.

Cover the lower part of the appliance with plastic sheeting or similar and place a suitable receptacle below the heat exchanger to collect the resultant debris and discharge.

Insert the cleaning nozzle of the hose into the burner opening. Switch on the pump and traverse the full length and circumference of the heat exchanger to remove any deposits. Remove excess moisture with a cloth and re-assemble in reverse order.

Section 13.3.2 Cleaning by removal of heat exchanger.

Isolate and drain down the boiler module, disconnect flow and return hoses. Remove the two M10 fastenings securing the left hand side of the module casing onto the frame. Lift the module off the supporting pins located on the right hand side, note the pins are of different lengths to assist with engagement when re-building.

NOTE: Each module holds approximately 4 - 5 litres of water and weighs 50 kg. It is **strongly recommended**

that a minimum of two people are on hand to lift the module from the frame. Alternatively, two lifting eyes are provided for use with suitable lifting equipment.

Once the module is lifted clear of the frame carefully rotate through 90° so that the heat exchanger central axis is vertical and the front casting is face down with the water connections uppermost. Support the module off of the floor on blocks of wood to protect from damage.

Remove the water connection fitting at the rear of the casing secured by M8 nuts and washers – **Note**, there is an 'O' ring used on each fitting.

Remove the 4xM10 nuts securing the front casting to the aluminium casing and carefully lift the casing vertically upwards away from the heat exchanger. Unhook the stainless steel springs and remove the 16 stainless steel baffle plates to expose the finned tube bank. Wire brush both sides of the baffles to remove any deposits.

Thoroughly wire brush the finned tubes.

Re-assemble in reverse order and refit heat exchanger to the casing using a new gasket. Replace the water connection gaskets on the rear of the boiler. Re-connect the water connections using new 'O' rings. Carefully lift the module back onto the mounting frame and secure with the M10 nut and bolt on the left hand side mounting. Re-fit the hoses and check for soundness.

13.4 Re-assemble the fan/transition/burner assembly using new gaskets where necessary, and refit in reverse order. **Test all gas joints broken or disturbed for soundness before firing.** Re-light the boiler, check and adjust the combustion as described in **Section 11.4** onwards.

Re-fit the boiler covers and tidy floor around boiler as necessary.

14.0 REPLACEMENT OF FAILED COMPONENTS

There are a number of components listed below which can be replaced simply and quickly by following the given procedure. In each case the operation of replaced components must be checked by carrying out the appropriate part of the commissioning procedure. See **Section 11.0: COMMISSIONING & TESTING**.

NOTE: Isolate all electrical supplies to the boiler and turn off the gas supply before commencing any servicing or component exchange procedure.

To access components remove covers as described in section 13.2 paragraph 1.

14.1 Hot Surface Igniter and Flame Probe Assembly. Part Nos. 563801011 & 533805010

Note :- the igniter and probe ceramics are very fragile. Reference to figure 13.2 shows position of the igniter and flame probe assembly. Unplug the igniter from the harness and remove the single socket cap head screw securing the igniter to the burner flange. Carefully withdraw the igniter, renew as required and

generally remove any loose sooty deposits, clean as required. Replace igniter and secure socket cap head screw holding the igniter to the burner flange. Disconnect the flame sensing probe connection, remove the single socket cap head screw securing the probe to the burner flange and carefully withdraw the probe. Renew as required and generally remove any loose sooty deposits, clean as required.

Note – do not remove both securing screws as the separate flange and Mica sight glass will become detached.

14.2 Control Thermostat Renewal

The thermostat consists of a potentiometer and remote sensor. **Part nos. 563901312 & 533901397.**

To replace either the thermostat potentiometer, or sensor the following procedure must be followed.

Remove the screw securing the fascia panel to the controls housing and lay the fascia face down on the plate heat exchanger ensuring no strain on the ribbon cable. Disconnect the potentiometer/sensor cable plug from the PCB.

To replace potentiometer prise out the central disc from the centre of the on/off knob and loosen the collet nut securing the knob to the shaft. Pull off the knob and undo the securing nut on the central spindle.

To replace the thermostat sensor, isolate and drain down the boiler module. Unscrew the sensor from the elbow,.

Replace components in reverse order. When replacing the potentiometer knob, rotate the shaft fully clockwise and fit and tighten the collet nut finish by refitting the central disc onto the knob.

Refit and secure the fascia panel.

Run the boiler and check for correct operation.

14.3 Temperature Limiter (Limit Stat) Renewal.

Part Nos. 533901179

Remove the 'push on' spade connections from the temperature limiter body noting position of coloured cables. Remove plastic cover (if fitted) and unscrew holding nut to detach temperature limiter from housing. Remove the bulb from the heat exchanger pocket and check the operation of the device by carefully applying a heat source to the bulb. Set temperature limiter to 95°C and re-assemble temperature limiter ensuring correct cable notation. Refer to thermostat diagram if terminal identification differs from those given in Figure 9.1.2 (Boiler schematic wiring diagrams).

14.4 Main Gas Valve / Venturi

Part No. 533903033

Note: the gas valve and venturi are supplied as a matched and factory set assembly and should not require adjustment.

1) To replace the gas valve/venturi it is preferable to remove the complete fan assembly.

2) Unplug the connectors from the fan (two) and the gas valve. Remove the 4xM4 screws securing the die-cast

gas valve inlet elbow to the gas valve taking care not to lose the 'O' ring.

3) Disconnect the pressure feedback tube from the gas valve. Remove the 4xM5 screws/nuts securing the fan/venturi/gas valve assembly to the transition duct. **Note** the use of a spacer on the screw/nut nearest to the heat exchanger casting. Withdraw the assembly from the air inlet duct.

4) Remove the 2xM5 screws securing the venturi/gas valve assembly to the fan noting the cork sealing gasket.

5) Remove the copper feedback connecting elbow from the gas valve and refit to the replacement valve using a thread sealant. When replacing the gas valve, it is advisable to renew the 'O' ring. See recommended spares section for Part Nos.

For LPG applications, ensure that the gas orifice plate is undamaged and fitted into the recess in the gas valve outlet. (Refer fig 11.2). Do not over tighten screws in gas valve body.

7) Re-assemble in reverse order using new gaskets where necessary and ensuring correct orientation of the gas valve. Ensure electrical plugs are firmly and correctly located. Switch on gas and power supply and check for integrity of all joints using a proprietary leak detector. Ensure gas valve operation is correct and safe before continuing.

6) Re-light the boiler, check and adjust the combustion as detailed in **Section 11.4** onwards.

14.5 Fan Assembly

Part No. 563901376

1) To replace the fan it is preferable to remove the complete gas valve/venturi and fan assembly.

2) Unplug the connectors from the fan (two) and the gas valve. Disconnect the 15mm gas connection to the gas valve inlet.

3) Remove the 4xM5 screws/nuts securing the fan/venturi/gas valve assembly to the transition duct. **Note** the use of a spacer on the screw/nut nearest to the heat exchanger casting. Withdraw the assembly from the air inlet duct.

4) Remove the 2xM5 screws securing the venturi/gas valve assembly to the fan noting the cork sealing gasket.

5) Re-assemble in reverse order using new gaskets where necessary. Ensure all screws are tightened and electrical plugs are firmly and correctly located.

6) Re-light the boiler, check and adjust the combustion as detailed in **Section 11.4** onwards.

**14.6 Ignition Sequence Controller.
Part No. 533901379**

- 1) Remove the front screw and loosen the rear screw securing the fascia panel to the controls panel body. Carefully withdraw the fascia panel and secure on the two hooks on the control panel body.
- 2) Disconnect the plug connectors from the ignition pcb, remove the 2xM4 securing screws and withdraw the control.
- 3) Re-assemble in reverse order and re-light the boiler.

**14.7 Main control PCB
Part No. 533901417 Nat Gas
Part No. 533901418 LPG**

- 1) Remove the front screw and loosen the rear screw securing the fascia panel to the controls panel body. Carefully withdraw the fascia panel and secure on the two hooks on the control panel body. Disconnect the plug connectors from the main PCB. Carefully remove the board from the plastic support pillars and withdraw the control.
- 2) Re-assemble in reverse order and re-light the boiler.

15.0 RECOMMENDED SPARES

Please Note! To ensure the correct spare parts are despatched by our spares department, it is imperative that the complete Boiler/Control Panel Serial Numbers are given. The Boiler Serial Number is located on the Data Plate affixed to the aluminium casing. The Electrical Serial Number is located on the mounting bracket of the Control panel. These numbers **MUST** be quoted when ordering spare parts.

SPARES ITEM PART NO.

ELECTRICAL ITEMS

Fuse - T1A Slow Blow 5dia x 20mm—Main control fuse 'F1' (RH).....	533922006
Fuse - F1A Fast Blow 5dia x 20mm—Fan supply fuse 'F2' (RH).....	747225941
Main PCB Nat Gas	533901417
Main PCB LPG	533901418
Fascia PCB.....	533901382
Ignition Sequence Controller	533901379
Fan assembly.....	533901376
Control Thermostat Sensor.....	533901397
Control Thermostat Potentiometer & cable assembly.....	563901312

MECHANICAL ITEMS

Burner Assembly	563301029
Spares Gasket Set.....	563605209
Gas Valve /Venturi.....	533903033
Gas Orifice Plate – LPG.....	531101010
Hot Surface Igniter	563801011
Flame Sensing Probe.....	533805010
Temperature Limiter.....	533901179
Gasket - Burner to Heat Exchanger.....	531201007
Fan/Venturi Gasket	531201067
Flue Seal 50Ø.....	532511035
Flue Seal 80Ø.....	532511036
Flue Seal 100Ø.....	532511037
Viewing port (sight glass).....	539907001

For service or spares please contact:-

**Hamworthy Heating Ltd.
Fleets Corner
Poole
Dorset BH17 0HH**

**Phone No. 01202 662500
Fax. No. 01202 665111
Service 01202 662555
Spares 01202 662525
Technical 01202 662566**

Appendix A Ferndown

INFORMATION RELATING TO PROPANE FIRING

NOTE!

LPG FUELS - IT IS STRONGLY RECOMMENDED THAT, ON LPG INSTALLATIONS, GAS DETECTION EQUIPMENT IS FITTED. THIS EQUIPMENT SHOULD BE POSITIONED NEAR THE BOILER AND AT LOW LEVEL. IT IS ALSO IMPORTANT THAT THE SPACE HOUSING THE BOILER IS ADEQUATELY VENTILATED AT HIGH AND LOW LEVEL. REFER TO MAIN INSTALLER'S GUIDES.

1.0 INTRODUCTION

The operation of the Ferndown on LPG-Propane (3rd family)_{I_{3P}} is similar to that on Natural Gas (2nd family)_{I_{2H}} and the design and installation details described in the main body of the installer's guide should be followed. There are however, differences in the construction and setting of the propane fired appliance which are as follows: -

a) The addition of a main gas orifice located in the

gas valve outlet – see Figure 11.2.

b) Relevant labels are replaced to indicate the appropriate gas for which the boiler is set up to fire.

c) The nominal gas inlet pressure for propane should be 37mbar.

The following tables and paragraphs, using the same numbering system as the main installer's guide, highlight the different values and procedures to be used when firing propane, and should be used in conjunction with the Main Installer's Guide.

2.2 Performance and General Data Information – LPG Propane

GENERAL DATA		FERNDOWN
Boiler Input kW (Gross)	- maximum	77.7
Boiler Input kW (Nett)	- maximum	70.0
Boiler Input kW (Gross)	- minimum	15.5
Boiler Input kW (Nett)	- minimum	14.0
Space Heating Output kW	-minimum	13.6
Space Heating Output kW	- maximum	63.7
DHW output (30°C rise)	l/min	30.4 (1825 l/h)
DHW output (44°C rise)	l/min	20.7 (1244 l/h)
FLUE DATA		
Nominal Flue Dia. mm		Single pipe = 100, dual concentric = 80/125 or 100/150
Approx. Flue Gas Temperature	°C	140
Approx. Flue Gas Vol. @ 10.5 – 11.5% CO ₂ & NTP(Dry)	m ³ /h *	102
GAS DATA		
Nominal Gas Inlet Press.	mbar	37
Maximum Gas Inlet Press.	mbar	45
Gas Flow Rate -maximum	m ³ /h (kg/h)	2.9 (5.5)
Gas Inlet Connection Pipe Thread Size		Rp ³ / ₄ "

11.0 COMMISSIONING AND TESTING

11.5.3 Combustion Checks

For propane firing models, the nominal gas inlet pressure is 37mbar with a maximum inlet pressure of 45mbar.

Adjust CO₂ and offset as described for nat gas, target offset value 0 to -0.05 mbar

11.5.4

Combustion figures for Propane should be as follows :-

CO₂ = 10.5 ± 0.1% (Dry flue gas)

O₂ = 4.5—5.5%

CO = 0-50ppm: However figure should not exceed 200ppm under normal operating conditions.

USEFUL USER INFORMATION

INSTALLER	SITE ADDRESS

DATE OF COMMISSIONING:

BOILER TYPE	BOILER SIZE(S)	UNIT NO(S).	SERIAL NO(S).	FLUE

NOTES:

THIS PAGE BLANK

Notes

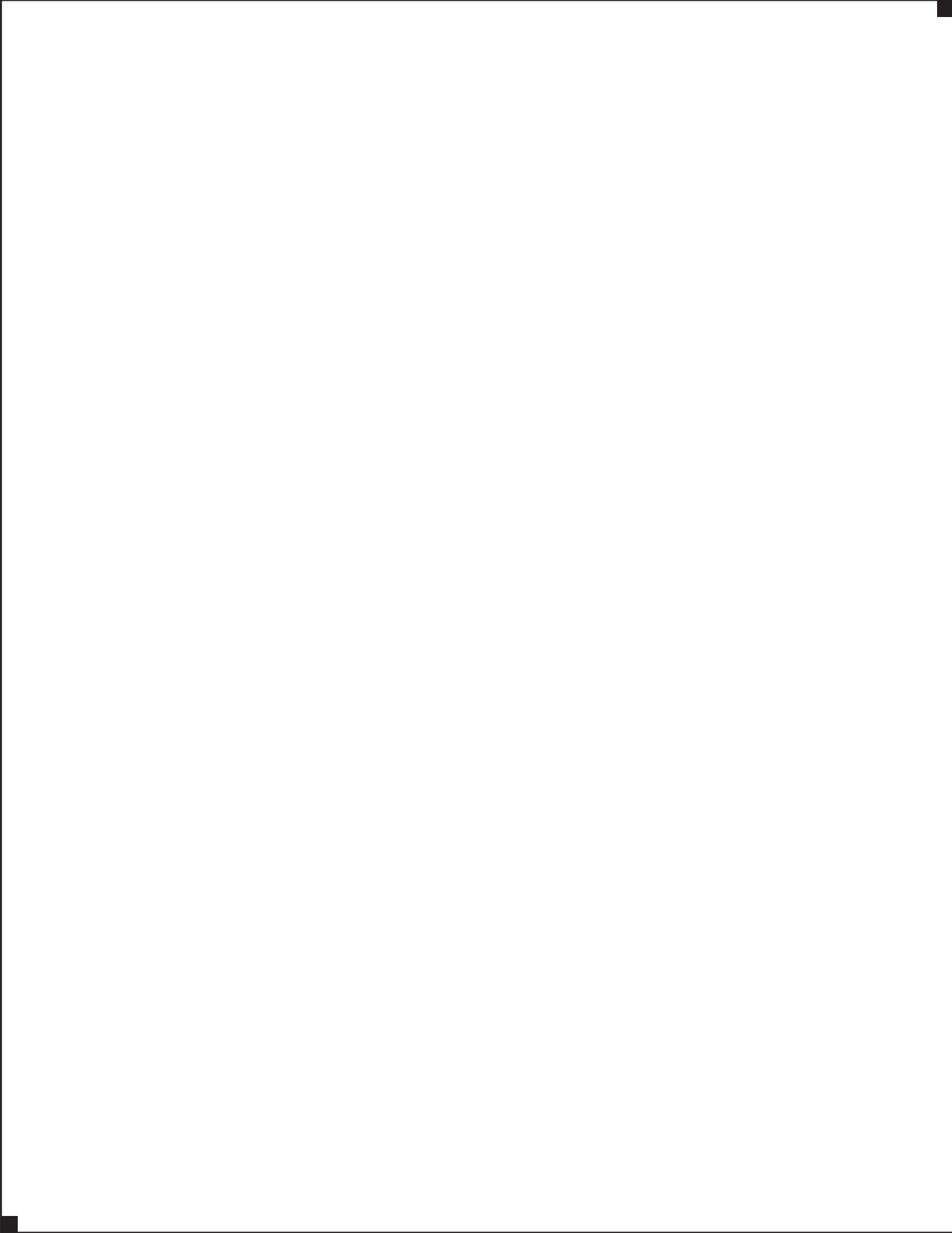

Connect direct

Direct Dial Telephone and Fax Numbers



HEATING & HOT WATER PRODUCTS





- boilers
- controllers
- water heaters
- pressurisation sets

Poole Office

Hamworthy Heating Limited

Fleets Corner, Poole, Dorset BH17 0HH England

Main switchboard tel: **01202 662500**

Technical enquiries	 01202 662527/662528	 01202 665111
Spare parts	 01202 662525	 01202 665111
Service department	 01202 662555	 01202 662522



FLUE & CHIMNEY SYSTEMS

- flue components
- packaged fan dilution systems
- bespoke flue components
- bespoke flue systems
- design and installation

Birmingham Office

Hamworthy Heating Limited

Shady Lane, Great Barr, Birmingham B44 9ER

Main switchboard tel: **0121 360 7000** fax: **0121 325 2309**

General enquiries  **0121 360 7000**

Direct Email Addresses

Customer Services spares@hamworthy-heating.com
service@hamworthy-heating.com
technical@hamworthy-heating.com
sales.flues@hamworthy-heating.com

Hamworthy Heating Accredited Agents

North West England

Gillies Modular Services

210-218 New Chester Road, Birkenhead, Merseyside L41 9BG

tel: **0151 666 1030** fax: **0151 647 8101**

Southern Ireland

HEVAC Limited

Naas Road, Dublin 12, Ireland

tel: **00 3531 141 91919** fax: **00 3531 145 84806**

Northern Ireland

HVAC Supplies Limited

Unit 2, Antrim Line Business Park, Sentry Lane, Newtownabbey BT36 8XX

tel: **02890 849826** fax: **02890 847443**

Scotland

McDowall Modular Services

14-46 Lomond Street, Glasgow, Scotland G22 6JD

tel: **0141 336 8795** fax: **0141 336 8954**

North East England

Allison Heating Products

17 Beech Road, South Shields, Tyne & Wear NE33 2QH

tel: **0191 455 7898** fax: **0191 455 7899**

Website

www.hamworthy-heating.com

Associate Companies, Offices and Agents throughout the World.

Hamworthy reserves the right to make changes and improvements which may necessitate alteration to the specification without prior notice.